



DB12

ASTONMARTIN.COM®

Welcome

Welcome to your new Aston Martin DB12.

This Owner's Handbook has been designed to explain the vehicle's operation and to make the control of its systems easy to understand and operate. All new owners are recommended to read the Owner's Handbook prior to driving. This Owner's Handbook forms part of the essential vehicle equipment for homologation purposes and must stay with the vehicle at all times.

Warnings, Cautions and Notes

The following Warnings, Cautions and Notes are used within this Owner's Guide to call your attention to specific types of information.

 **Warning: Provided to show procedures which must be followed precisely to help avoid the risk of personal injury.**

 **Caution: Provided to show procedures which must be followed precisely to reduce the possibility of damage to your vehicle.**

 Provided to show procedures which will help to avoid difficulties in the operation of your vehicle.

Component Location

All directions for locating components are described as viewed from the driver's seat, i.e. the fuel filler flap shown on this diagram will be described as 'located at the rear right side of the vehicle'.

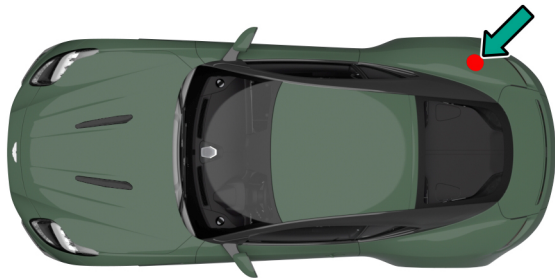

Vehicle Identification

The Vehicle Identification Number (VIN) is shown in the left side bottom corner of the windscreen.

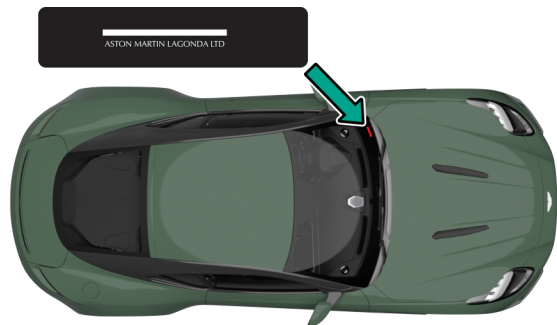

The VIN plate can also be found in the passenger side door shut panel and laser etched onto the right side footwell.

 *To view the VIN etched into the floor panel, lift the carpet up from the front, and then lift the sound deadening material.*

Event Data Recorder (EDR)

This vehicle is equipped with an event data recorder (EDR).

The main purpose of an EDR is to record, in certain crash or near crash-like situations, such as an air bag deployment or hitting a road obstacle, data that will assist in understanding how a vehicle's systems performed. The EDR is designed to record data related to vehicle dynamics and safety systems for a short period of time, typically 30 seconds or less.

The EDR in this vehicle is designed to record such data as:

- How various systems in your vehicle were operating;
- Whether or not the driver and passenger safety belts were buckled/fastened;
- How far (if at all) the driver was depressing the accelerator and/or brake pedal; and,
- How fast the vehicle was traveling.

These data can help provide a better understanding of the circumstances in which crashes and injuries occur.

 *EDR data are recorded by your vehicle only if a non-trivial crash situation occurs; no data are recorded by the EDR under normal driving conditions and no personal data (e.g., name, gender, age, and crash location) are recorded.*

However, other parties, such as law enforcement, could combine the EDR data with the type of personally identifying data routinely acquired during a crash investigation.

To read data recorded by an EDR, special equipment is required, and access to the vehicle or the EDR is needed.

In addition to the vehicle manufacturer, other parties, such as law enforcement, that have the special equipment, can read the information if they have access to the vehicle or the EDR.

Reporting Safety Defects

North America

If you believe that your vehicle has a defect which could cause a crash or could cause injury or death, you should immediately inform the National Highway Traffic Safety Administration (NHTSA) in addition to notifying Aston Martin Lagonda of North America Inc., 9920 Irvine Center Drive, Irvine, CA 92618, USA.

If NHTSA receives similar complaints, it may open an investigation, and if it finds that a safety defect exists in a group of vehicles, it may order a recall and remedy campaign. However, NHTSA cannot become involved in individual problems between you, your Dealer, or Aston Martin Lagonda (North America) Inc.

To contact NHTSA:

Call the Vehicle Safety hot-line toll-free at 1-888-327-4236 (TTY: 1-800-424-9153)

Go to www.safercar.gov

Write to: Administrator, NHTSA, 400 Seventh Street, SW., Washington, DC 20590.

You can also obtain other information about motor vehicle safety from www.safercar.gov.

Canada

If you believe that your vehicle has a defect which could cause a crash or could cause injury or death, you should immediately inform Transport Canada in addition to notifying your Aston Martin Dealer.

To contact Transport Canada, call their toll-free number: 1-800-333-0510 or go to <http://tc.canada.ca/recalls> or <http://tc.canada.ca/rappels>.

Health

CALIFORNIA Proposition 65

⚠ Warning: Engine exhaust, some of its constituents, and certain vehicle components contain or emit chemicals known to the State of California to cause cancer, and birth defects or other reproductive harm. In addition, certain fluids contained in vehicles and certain products of component wear contain or emit chemicals known to the State of California to cause cancer, and birth defects or other reproductive harm.

⚠ Warning: Battery posts, terminals and related accessories contain lead and lead compounds. Wash hands after handling.

Perchlorate Material

Certain components of this vehicle such as air bag modules, seat belt pre-tensioners and roll over protection devices may contain Perchlorate Material. Special handling may apply for service or vehicle end of life disposal. Go to www.dtsc.ca.gov/hazardouswaste/perchlorate for more information.

Driving Safety

- Always wear your seat belt.
- Never drive under the influence of alcohol or drugs.
- Always obey all speed and traffic laws and regulations. Never drive faster than the posted speed limit or than conditions allow.
- Be particularly careful driving on slippery or wet surfaces.
- This vehicle is a high performance vehicle and has handling characteristics you may not be accustomed to. Familiarize yourself with the vehicle and always drive prudently, being aware of your own limitations and the limitations of the vehicle. As with other vehicles of this type, failure to operate the vehicle correctly can result in accident and injury.
- Follow the maintenance schedule approved in this guide.
- Never allow the vehicle to be driven by inexperienced drivers.

📖 Make sure that you are wearing appropriate footwear to efficiently operate the control pedals. Make sure that pedal movement is not restricted by floor mats or other objects trapped beneath pedals.

Cyber Security Systems

Cyber security systems on this vehicle are designed to reduce the risk of unauthorized access to connected vehicle components from malware - malicious software. This can take the form of internet based attack on vehicle control modules to affect functions or access data.

Connected Car Components

Several components on this vehicle make up the Connected Car system, which communicates with external devices or the internet for a number of functions such as multimedia and diagnostics. These components are critical areas for cyber security and each take a variety of measures to protect devices from unauthorized external access.

Examples of Connected Car device can include:

- The On Board Diagnostic (OBD) Port.
- Telematics Gateway Module.
- Mobile Phone Interface and Related Connected Car Apps.
- Bluetooth® System.
- USB port.
- Security Tracker.

Security Updates

The software and security systems in this vehicle are subject to continuous improvement and development. As part of this, regular software updates may be necessary to improve the security, stability and running speeds of the Connected Car systems in this vehicle.

Risk Reduction

 ***Computers, mobile devices and data media that can be connected to the internet or that are used in either public or private networks are at risk of being infected with manipulated data or malware. Always take suitable steps, such as a suitable up to date anti-virus program, to protect such devices.***

To reduce the risk of unauthorized access to vehicle systems and functions, always have the vehicle inspected, service and repaired at an authorized Aston Martin Dealership. In addition, never use portable USB and mobile devices with the vehicle that are known contain malware, or corrupted or manipulated data.

Even with security systems in place, it is possible that malware can cause malfunctions in control modules that affects some vehicle functions. If your vehicle is affected whilst driving or if a system operates differently from usual, reduce your speed in a controlled manner and contact your nearest Aston Martin Dealer.

 ***Malware can also access data and information that are stored in modules, the Infotainment system and on connected devices such as a mobile device or USB Media.***



Aston Martin Owners' Club (AMOC)

An invitation to join the Aston Martin Owners' Club

The sporting spirit of the 1930s exists today in one of the world's most exclusive car clubs. Enthusiasts in nearly 60 countries are united by an interest in iconic cars with an enviable pedigree. Enjoy the company of like-minded owners in a wide range of activities: social evenings, weekends away or motoring tours. Something more competitive? AMOC Concours are a benchmark for connoisseurs of fine motorcars. A need for speed? We organize track days, sprints and hill climbs as well as circuit racing in venues such as Silverstone, Goodwood and Lime Rock in the USA.



Aston Martin Owners' Club

Drayton St. Leonard

Wallingford

Oxfordshire

England

OX10 7BG

+44 (0) 1865 400 400

E-Mail: hqstaff@amoc.org

Website: www.amoc.org

Aston Martin Heritage Trust

The Aston Martin Heritage Trust is an educational charity dedicated to the preservation, promotion and enhancement of over 100 years of history of Aston Martin. Its world class collection comprising the automotive museum, substantial archive and collection of historical artefacts is housed in the magnificently restored Grade II* listed barn in Oxfordshire which it shares with the Owners' Club. As a member of the Owners' Club you become a member and supporter of the Trust, so please log on to our web site for more information, or better still pay us a visit and see the collection for yourself.



Aston Martin Heritage Trust

Drayton St. Leonard

Wallingford

Oxfordshire

England

OX10 7BG

Telephone: +44 (0) 1865 400 414

E-Mail: secretary@amht.org.uk

Website: www.amht.org.uk



Quick Start	1
Vehicle Security	2
Before Driving	3
Controls	4
Driving	5
Climate Control	6
Phone System.....	7
Connected Car	8
Media Systems	9
Navigation.....	10
Convertible Roof	11
Vehicle and System Settings	12
Maintenance and Technical Data	13
Service.....	A
Aston Martin Warranty	B
Aston Martin Assistance	C
Certification and Compliance	D
Alphabetical Index	F

Every effort has been made to make sure that the information provided in this Owner's Handbook is accurate and up-to-date. However, neither the manufacturer or the Dealer, by whom this Owner's Handbook is supplied, will in any circumstances be held responsible for any inaccuracy or the consequences thereof.

Software instructions in this handbook are correct at time of print. However, these may be subject to change due to ongoing software updates during the vehicle's lifetime. Contact your Aston Martin Dealer for further information.

© Copyright Aston Martin Lagonda Limited, 2023. All Rights Reserved. This publication is provided with your vehicle for your personal, private and non-commercial use. No part of this publication may be reproduced, stored in a retrieval system or transmitted, in any form, electronic, mechanical, photocopying, recording or other means without prior written permission from Aston Martin Lagonda Limited.

The manufacturer reserves the right to vary specifications without notice in accordance with its policy of continual product improvement.

Aston Martin Lagonda Limited

Banbury Road

Gaydon

Warwick

CV35 0DB

England

Telephone: +44 (0)1926 644300

Issue 2: August 2023

Part Number: RY53-19A321-HB

Barcodes conform to AML specification AMES000043

Quick Start

Vehicle Key.....	1.2
Driving Position	1.3
Vehicle Controls.....	1.5
Infotainment.....	1.9

Vehicle Key

What Do The Buttons On The Key Do?



[1] LOCK: Press to lock the vehicle and arm the security system.

[2] UNLOCK: Press to unlock either the driver's door or the vehicle.

[3] DECK LID OPEN: Press and hold to release the deck lid catch.



Global Close

Press and hold  to unlock all vehicle doors and open all windows.

Press and hold  to lock all doors and close all windows.
Volante: Global close will also open or close the convertible roof.

Keyless Entry

To unlock the vehicle, fully push the front edge of the door handle. If the system recognizes a valid key signal, the door will unlock and open.

To lock the vehicle, close all the vehicle doors and press the rear edge of the door handle to activate the lock switch.

Driving Position

How Do I Adjust The Seat?

Electric Seat Adjustment

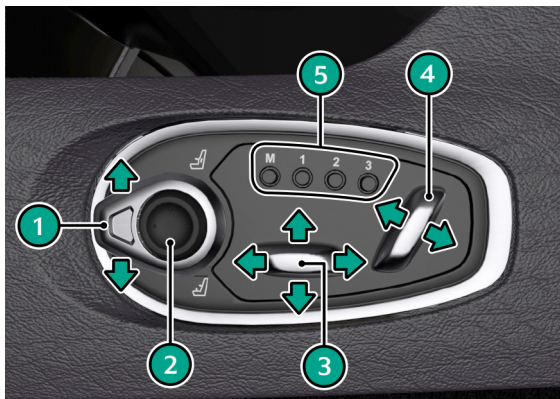

[1]: Bolster/Lumbar selector switch (Optional).

[2]: Bolster/Lumbar adjustment (Optional).

[3]: Seat base adjust.

[4]: Seat backrest adjust.

[5]: Memory seat positions.

Manual Seat Adjustment

(Performance Seat only)

Pull the release strap to allow adjustment of the seat base.



How Do I Get To The Back Seats?

Pull the release strap (A) to release the seat back. Pull and hold to move the rear of the seat forward.



What Do The Door Switches Do?



[A]: Door Mirror Selector.

[B]: Door Mirror Adjustment.

[C]: Window Switch.

[D]: Deck lid (press and hold).

Vehicle Controls

What Do The Centre Console Switches Do?

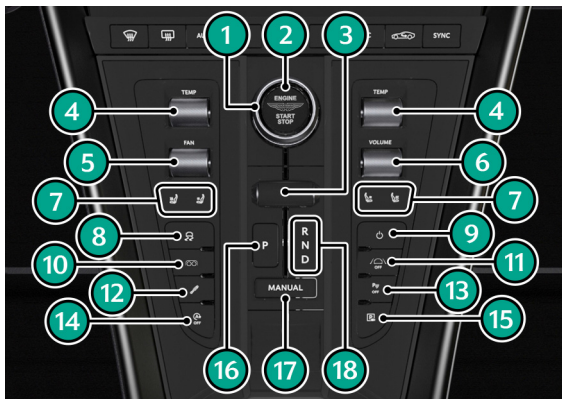

[1] DRIVE MODE SELECTOR: Rotate to select drive modes.

[2] ENGINE START/STOP: Press to start or stop the engine.

[3] TRANSMISSION SELECTOR: Use to select a transmission mode.

[4] TEMPERATURE: Adjust the temperature for the climate control.

[5] FAN SPEED: Adjust the fan speed.

[6] VOLUME: Adjust the volume for the audio system. Press to mute audio.

[7] HEATED/COOLED SEATS: Press to change the level of seat heating or cooling.

[8] ELECTRONIC STABILITY CONTROL: Press and hold to cycle ESP modes.

[9] INFOTAINMENT ON/OFF: Set the infotainment system to on or off.

[10] EXHAUST MODE: Press to cycle exhaust modes.

[11] LANE KEEP ASSIST: Set the lane keep assist to on or off.

[12] ADAPTIVE DAMPING: Press to cycle adaptive damping modes.

[13] PARK DISTANCE CONTROL: Press to set the Park Distance Control (PDC) sensors to on or off.

[14] STOP/START: Use to set the eco stop/start function on or off.

[15] CAMERA: Changes the infotainment system display to the camera system.

[16] PARK SELECT: Press to select Park.

[17] MANUAL MODE: Press to enter manual transmission mode.

[18] TRANSMISSION STATUS INDICATOR: Shows selected transmission mode.

What Are The Steering Wheel Controls?

Switches

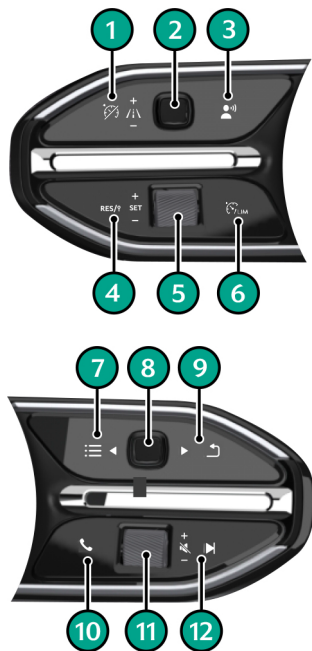

[1] CANCEL:

Tap to cancel the set speed.

[2] ADJUST DISTANCE:

Swipe to adjust the set distance between the vehicle in front and your vehicle during Active Cruise Control (ACC).

[3] START VOICE CONTROL:

Tap to use voice control system for mobile devices.

[4] RES:

Tap to resume a set speed in the speed control systems or adopt a new speed limit in ACC.

[5] SPEED SET SWITCH:

Use the roller dial to adjust the set speed for the ACC or variable speed limiter. Press the switch to set a speed.

[6] SPEED CONTROL SYSTEM SELECT:

Tap to switch between Adaptive Cruise Control (ACC) and variable speed limiter functions (Refer to 'Speed Control Systems', page 5.14).

[7] MENU HOME:

Tap to open the instrument cluster menu (Refer to 'Instrument Cluster Menu', page 4.9).

[8] MENU SCROLL BUTTONS:

Swipe through the menu to navigate the instrument cluster menu. Press the button to select an item in the menu (referred to in this handbook as **OK**).

[9] MENU BACK:

Tap to go back one level in the instrument cluster menu.

[10] CALL:

Tap to answer an incoming call or open the last dialed number. Press again to end a call or reject an incoming call (Refer to 'Calls', page 7.4).

[11] VOLUME:

Use the scroll wheel to adjust the volume for the audio system. Press to mute audio.

[12] NEXT TRACK:

Tap to skip to the next audio track.

Transmission Paddles

Pull back on either paddle to enter *Semi-automatic* transmission mode.



Once in *Semi-automatic* or *Manual* mode, use the paddles to change gear.

[1]: Downshift Paddle

[2]: Upshift Paddle

What Do The Stalks Control?

Indicators and Headlamp Beam



Main Beam

Push the stalk for main beam headlamps. Pull the stalk back to the initial position to return to dipped beam headlamps.

Flash Headlamps

Pull the stalk to flash the main beam headlamps.

Direction Indicators

Press up to briefly indicate a right turn and down for a left turn. Press until the switch latches to hold the selected indicator on.

Wiper Controls

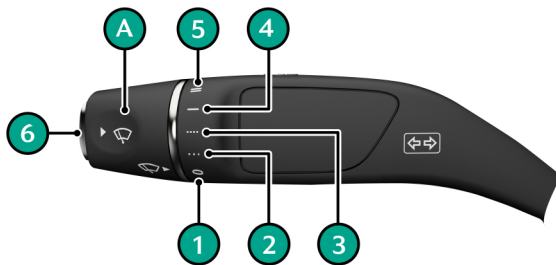

Rotate the wiper speed selector (A) to select a wiper speed.

[1]: Windscreen wipers off

[2]: Intermittent wipe (low rain sensor sensitivity)

[3]: Intermittent wipe (high rain sensor sensitivity)

[4]: Continuous wipe (slow)

[5]: Continuous wipe (fast)

[6]: Press for single wipe. Press and hold to operate the front windscreen washers.

How Do I Turn On The Exterior Lamps?



- [1]: Left side park lamp
- [2]: Right side park lamp
- [3]: Side lamps (including number plate lamps)
- [4]: Automatic headlamp mode
- [5]: Dipped beam headlamps
- [6]: Rear foglamp

Infotainment

How Do I Pair A Bluetooth Device?

To add a new device, select  from the main menu. The vehicle will automatically search for available devices to connect to.

Available devices will be shown as a list with the option to connect to individual devices. The *Device Manager* button will also be available to manage individual devices.

To connect a device, select it from the list and tap connect.

For more information on bluetooth device management (Refer to 'Bluetooth Device Management', page 7.2)

How Do I Operate The Media System?

Tap  to access the media systems.

The Now Playing screen has some common elements that appear regardless of which source medium is used.

Individual media controls are explained in their relevant sections.

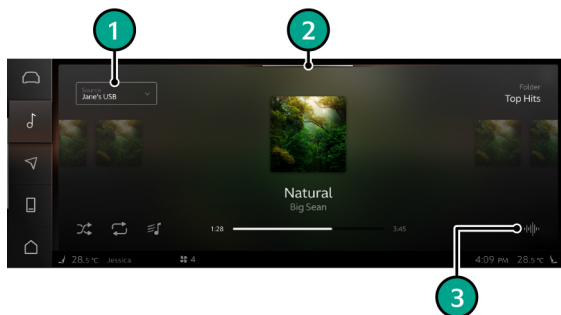

[1] SOURCE: Tap to change media source (Refer to 'Source', page 9.4).

[2] MINIMIZE: Swipe down to minimize media screen to the bottom bar.

[3] SETTINGS: Opens the **Settings** menu (Refer to 'Sound Settings', page 9.18).

How Do I Set A Navigation Destination?

Tap  to access the navigation system.

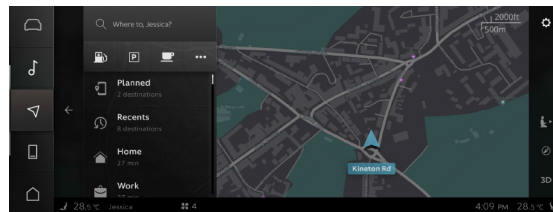

Tap the **Where to?** text box to input an address or select a saved location such as home or work.

Vehicle Security

Vehicle Key.....	2.2
Unlocking and Opening	2.6
Emergency Access and Start.....	2.11
Anti-Theft Systems.....	2.13
Homelink® Wireless Control	2.15

Vehicle Key

The vehicle is supplied with two vehicle keys. Keep the second key in a safe place. Never leave a vehicle key in the vehicle when unattended.

⚠ Warning: The engine can be started by any person in the vehicle if the brake pedal is pressed down and the start button is pressed. Care should be taken that the vehicle key is not left in the vehicle with only occupants such as young children or pets inside.

 If a vehicle key is lost, contact your Aston Martin Dealer.

 If the vehicle key is not in the vehicle, the message 'Key Not Detected' will be displayed in the instrument cluster when trying to start the vehicle. This message will also be displayed if the vehicle key battery does not have enough charge to be detected by the keyless start system.

Vehicle Key Functions



[1] LOCK: Press to lock the vehicle and arm the security system.



[2] UNLOCK: Press to unlock either the driver's door or the vehicle.



[3] DECK LID OPEN: Press and hold to release the deck lid catch.



One Step Unlocking

The vehicle key can be set to either unlock only the drivers door on a single press of  or all vehicle doors.

To cycle between single door unlock and full unlock, press and hold  and  at the same time for 6 seconds.

 If the vehicle is set to only open the driver's door, a second press of  will open all vehicle doors.

 Lock operation of the fuel filler flap is not affected.

 One Step Unlocking can only be set using the vehicle key.

Vehicle Key Battery

 **Warning:** Using the incorrect battery type can cause the vehicle key to not operate correct, or can cause fire or explosion. Always use the correct battery type when the battery is replaced.

 **Warning:** The vehicle key contains a small cell battery. Do not ingest or swallow the battery. If the battery is swallowed, there is a risk of choking, severe internal chemical burns or death. Always keep both new and used batteries away from children and do not allow children to use the vehicle key. If you suspect a battery has been swallowed, immediately seek medical attention.

Battery Power Conservation

The vehicle key can be deactivated to conserve battery power in the vehicle key.

If the vehicle key is not moved for a set period of time, it will automatically deactivate.

To manually deactivate the key, double tap .

Battery Replacement

To replace the vehicle key's battery:

1. Remove the emergency key from the vehicle key.
2. Use the emergency key to release the tab holding the top cover for the vehicle key.

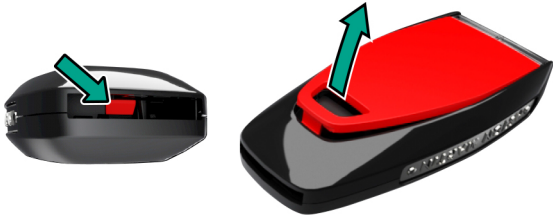

3. Use the emergency key to release the tab holding the battery tray.



4. Replace the battery for the vehicle key.

 *The vehicle key uses a CR2032 battery.*



Keyless Go Zones

The Keyless Go function for vehicle locking and ignition will operate when a vehicle key is inside the vehicle cabin or in one of the below reception zones:

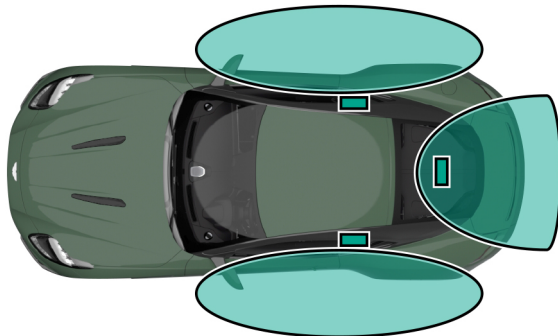



 *The vehicle key is only needed in one of the reception zones for Keyless Go. For example, the vehicle key can be in the rear reception zone and the passenger side door can be unlocked.*

Unlocking and Opening

Unlocking From Outside the Vehicle

Using The Vehicle Key

Stand within 5 m (16 ft) of the vehicle, and press . To show that the security system has been disarmed and the vehicle unlocked, the direction indicators will flash¹. The vehicle door handles will be presented. Pull the door handle to open the door.

 For ease of use at night white LEDs are incorporated into the door handles which illuminate when the vehicle is unlocked. The door LEDs will go off after 40 seconds or if the vehicle is locked again.

Global Close

Press and hold  to unlock all vehicle doors and open all windows.

Press and hold  to lock all doors and close all windows.

Volante: When global close is used, the convertible roof will also open or close with the windows respectively.

Using Keyless Entry

To unlock the vehicle with keyless-entry active, gently push at point (A) and open the door handle. If one step unlocking has not been set, the only the driver's side door will open the passenger door on a second unlock request. Presenting handles will retract after 25 seconds, if the vehicle is locked or if the vehicle is driven.

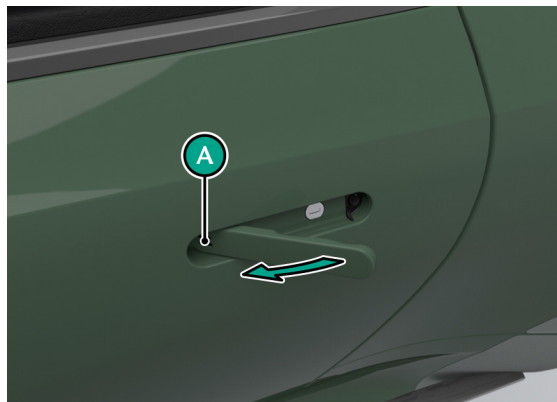

¹ An audible confirmation can also be set in the vehicle settings (Refer to 'Comfort', page 12.5).

Presenting Handle

Whenever the vehicle is unlocked the door handles will present from the door to give ease of access. Presenting handles also match one step unlock configuration if set.

Door Opening Whilst Driving



If a door is opened while driving a warning sound will be heard and a warning will be shown on the instrument cluster until the door is closed again.

Locking From Outside the Vehicle

Using The Vehicle Key

Close all the vehicle doors. Stand within 5 m (16 ft) of the vehicle, point the vehicle key towards the vehicle and



press . The direction indicators will flash and all vehicle doors will lock. If automatic fold-in mirrors has been set to on in the vehicle settings, the mirrors will fold closed.

 If  is pressed with the driver's door open, the vehicle will not lock until that door has been closed.

Using Keyless Entry

Close all the vehicle doors. Press the rear edge of a door handle to activate the lock switch. The direction indicators will flash and all vehicle doors will lock. If automatic fold-in mirrors has been set to on in the vehicle settings, the mirrors will fold closed.

Interior Lock Switches

The doors can be locked and unlocked by using the master unlock  (1) and lock  (2) switches.



If the vehicle is locked using the master lock switch, one pull of a door handle will centrally unlock the doors and will open that door.

If the vehicle is not locked using the vehicle key, the master lock switch will operate seven minutes after the ignition control has been turned off.

 *In the event of a vehicle accident the doors will automatically unlock.*

Automatic Locking Feature

The central locking can be set to automatically activate once the vehicle speed exceeds 15 km/h (9 mph).

The automatic locking feature can be activated or deactivated in the vehicle settings menu (Refer to 'Comfort', page 12.5).

 *The vehicle must be stationary to change the status of the automatic locking feature.*

Easy Entry/Exit

⚠ The Easy Entry/Exit function could cause an occupant to become trapped and/or cause injury. Keep clear of the steering wheel when the Easy Entry/Exit function is used.

📖 Easy Entry/Exit movement can be cancelled by moving the adjustment lever for the steering column or by selecting a memory position.

To aid entry and exit from the vehicle, the steering wheel can be set to move when the driver's door is opened.

Easy Entry/Exit can be set in the vehicle settings menu (Refer to 'Comfort', page 12.5).

Deck Lid

Volante Only

Decklid operation will be disabled when the tonneau cover for the convertible roof is open. Fully open or close the convertible roof to be able to access the luggage compartment.

Opening The Deck Lid Outside the Vehicle

Press and hold  (A) on the vehicle key to enable the release catch and lift the deck lid.



📖 If the vehicle is locked when  is pressed, the doors will remain locked and the security system will still be armed.

Opening the Deck Lid Inside the Vehicle

Press and hold the deck lid release button (B). The deck lid catch will release. Lift the lid.



Closing the Deck Lid

Push the deck lid down and make sure that the catch engages. Once the catch engages, it automatically closes. If the deck lid is slammed shut, this is overridden.

If a vehicle key is left in the luggage compartment and the deck lid is closed, but the rest of the vehicle is locked, the latch will not engage. The key(s) must be removed from the luggage compartment before the deck lid can be locked. If a second key is in range outside the vehicle the latch will engage and lock the deck lid. There will also be an audible or visible lock confirmation dependant on settings.

Emergency Access and Start

Emergency Key

If the vehicle key fails to operate, or the vehicle battery is fully discharged, use the emergency key to lock or unlock the vehicle.

 *The emergency door lock is always in the door handle for the left side door.*

! Caution: *If the vehicle has lost power, the door may require extra effort to open due to the window not dropping down. If this does happen, gently press against the top of the window whilst opening the door.*

! Caution: *If the vehicle battery is fully discharged, the emergency key will only lock or unlock the left side door. The right side door can be unlocked from inside the vehicle, but unless power is supplied to the vehicle, that door cannot be locked again.*

 *Even if the vehicle key has lost all power it will start the engine when used in the emergency ignition slot.*

Press and hold the button (A) to release the ratchet holding the emergency key (B) and pull the key out. The emergency key can either be fully removed or partially removed and operate as a keyring mount.

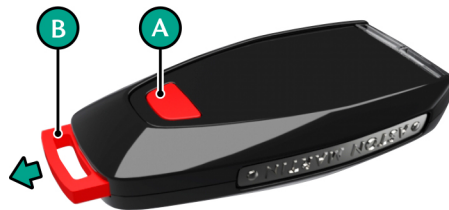

The emergency key can be used to unlock the left door. To unlock the door, open the door handle, insert the key into the door lock and turn.

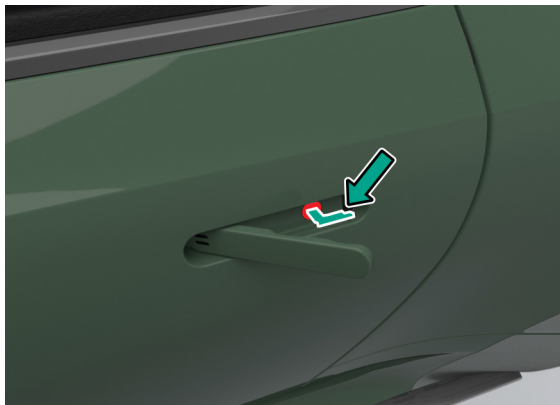

Emergency Deck Lid Release

The deck lid can be opened from inside the luggage compartment by pulling the luminous emergency release handle (A).

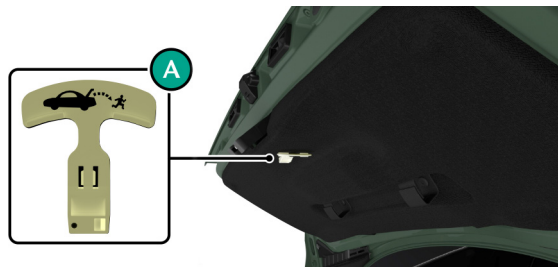

Anti-Theft Systems

Emergency Start

If the vehicle does not start and the message *Place the key in the marked space - See Owner's Manual* is shown in the instrument cluster:

1. Place the vehicle key in the space (A) in the cup holder.

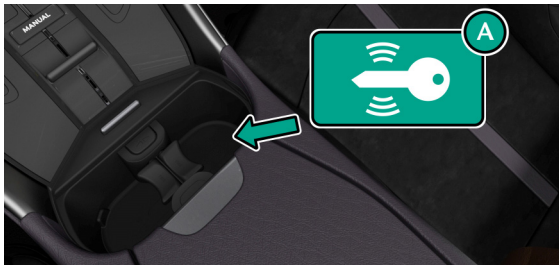

2. The vehicle will start after a short time.
3. Once the engine has started, the key can be moved.

If the vehicle does not start, leave the key in space (A), fully press the brake pedal down and start the vehicle with the stop/start button as usual.

Contact your Aston Martin Dealer to have the key checked.

Introduction

This vehicle is protected by an electronic security system which includes:

- Remote arm and disarm
- Perimeter sensing
- Remote door, deck lid, fuel flap lock and unlock
- Alarm siren with battery backup (Only in markets where audible sirens are permitted.)
- Random code encryption to prevent electronic scanning of the vehicle key identity code
- Engine Immobilizer
- Ultrasonic Interior movement sensors
- Tilt (tow-away) sensor

When the security system is armed, any attempt to gain access by breaking a window or forcibly opening a door, the deck lid or the hood will result in full alarm operation.

Alarm

When the alarm has started a siren will be heard for a 25 seconds cycle (ten cycles maximum) and the direction indicators flash¹ for five minutes after which the security system returns to the armed state.

The doors and deck lid will stay locked throughout.

Stop the alarm at any time by pressing  on the vehicle key or open a vehicle door with keyless entry active. There is approximately a ten second delay before the alarm is stopped.

Engine Immobilizer

The engine immobilizer prevents your vehicle from being started without the correct key.

The immobilizer system is activated when the ignition is set to off and the driver's door is opened.

! Caution: Always take the key with you when you lock the vehicle. The engine can be started if a valid key has been left inside the vehicle.

Interior Motion Sensor

When the vehicle is locked and armed, the interior motion sensor will sense movement inside the vehicle. If movement is detected it will start the alarm.

 *The interior motion sensor will activate 10 seconds after the vehicle is locked and all doors and the deck lid are closed, and the alarm will be set after a further 10 seconds of calibration.*

 *All doors must be closed before the interior motion sensor can be activated.*

The interior motion sensor can be set on or off in the vehicle settings menu (Refer to 'Comfort', page 12.5).

Tow Away Protection

When the vehicle is locked and armed a tilt sensor will sense if the vehicle is tilted or lifted. For example, if the vehicle is being raised on a jack or being towed. If the vehicle tilt sensor detects a tilt, the alarm will start.

 *Tow Away Protection will activate 60 seconds after the vehicle is locked and all doors are closed.*

 *All doors, including the deck lid, must be closed before tow away protection can be activated.*

Tow away protection can be set to on or off in the vehicle settings menu (Refer to 'Comfort', page 12.5).

¹. Markets where visible alarm signals and audible sirens are permitted.

Homelink® Wireless Control

(Optional)

The HomeLink®¹ Wireless Control buttons and transceiver are on the interior rear view mirror. The transceiver can be programmed to operate up to 3 transmitters to operate garage doors, entry gates, home lights, security systems, or other radio frequency operated devices.

⚠ Caution: As a security precaution make sure that all programming is erased in the HomeLink system before selling this vehicle.

For information or assistance, contact your Aston Martin Dealer.

⚠ Warning: Do not use the transceiver with any garage door opening system that lacks the safety stop and reverse feature as required by US federal safety standards. A garage door opening system which cannot detect an object, signalling the door to stop and reverse increases risk of serious injury or death.

⚠ Warning: When the transceiver is being programmed to a garage door opening system, make sure that people and animals, the vehicle and objects are clear to prevent injury or damage as the garage door or gate will operate during the programming.

 A full list of radio frequency operated devices can be either obtained on the HomeLink website.

 Keep the original transmitter for future use or programming procedures if, for example, you purchase a new vehicle.

 This device may suffer from interference if operated near to a mobile or fixed station transmitter. This interference can affect the hand-held transmitter as well as the in-vehicle transceiver.

 The manufacturer is not responsible for any radio or TV interference caused by unauthorized modifications to this equipment. Such modifications could void the user's authority to operate the equipment.

¹. Gentex®, HomeLink®, and the HomeLink® house icon are registered trademarks of Gentex Corporation.

Programming

 *Step 1 will clear previously programmed devices and is only necessary if programming HomeLink for the first time or when erasing all existing programming. This step is not necessary to program additional devices. The HomeLink® buttons can be reprogrammed individually but not individually erased*

1. Press and hold the two outer HomeLink buttons until the HomeLink symbol (A) begins to flash green after 10 seconds.

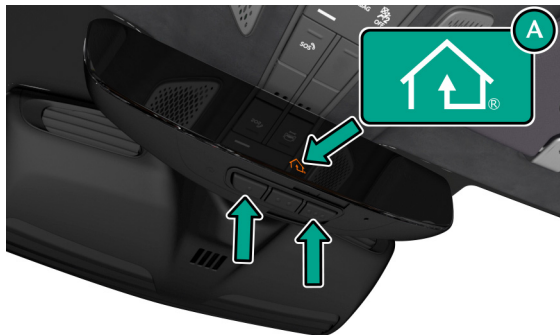

Release the two buttons. All three buttons are now cleared, and the HomeLink system is now in setting mode.

2. Press the HomeLink button you want to program. The HomeLink symbol should begin to slowly flash orange.
3. Press and hold the remote control for the device to be programmed at a distance of 20 mm to 80 mm (1" to 3") away from the HomeLink transmitter unit, keeping the HomeLink symbol in view.

 *The distance between the remote control and the transmitter unit depends on the system being programmed and several attempts at different distances may be necessary.*

4. Press and hold the remote control button until the HomeLink symbol turns to either rapidly flashing or continuously green.

 *Some markets require the remote control to time out after it's button is pressed and held for a certain amount of time. If the indicator light on the remote control goes off whilst programming, press and release the remote control button every 2 seconds until the symbol changes to green.*



5. Press the newly programmed HomeLink button.
 - If the symbol stays constantly green, programming is complete and your device should operate when the HomeLink button is used.
 - If the symbol rapidly flashes green, press and hold the HomeLink button for two seconds twice. Depending on the brand of the device, you may need to press and hold for a third time to complete the programming process. At this point if your device operates, programming is complete.
 - If the your device does not operate, refer to you device's manual to see if there are steps required on your device to complete the programming of a rolling code equipped device.

Operation

The vehicle should be within the operating range of the device and the ignition should be on.

The HomeLink system operates the garage door opener (or other device) in the same way as the original remote control.

 *The original remote control may also be used at any time.*



Press the programmed HomeLink button to operate the device.

The HomeLink symbol will come on when the button is pressed and will stay on while the garage door opener (or other device) operates.

Reprogramming

To program a new device, press and hold the desired HomeLink button for 20 seconds until the LED starts flashing slowly. That button may now be programmed to work with a different device.

 *If you do not complete programming the new device, the previous device will still be programmed to that button.*

Before Driving

Checks Before Driving	3.2
Seats	3.2
Windows	3.5
Mirrors	3.7
Steering Column	3.8
Memory Functions.....	3.9
Occupant Restraint System	3.11
Child Safety	3.20
Child Seat Installation	3.25
Cabin Storage	3.31
Accessory Sockets	3.34

Checks Before Driving

Inspect your vehicle to make sure that everything is in accordance with the information and specifications in this Owner's Guide.

Outside the Vehicle:

- Visually check the road wheels, wheel bolts and tires.
- Check that all windows, mirrors and lamps are clear and unobstructed.
- Check that the deck lid, hood and fuel filler flap are securely closed.
- Check the operation of all lamps.

Once Inside the Vehicle:

- Check that the doors are securely closed.
- Check that the seat, mirrors and steering wheel adjustments are correct.
- Check that all gauges and symbols are reading correctly.
- Check that all passengers have fastened their seat belts.

Seats

Front seats only.

 **Warning: Do not adjust the drivers seat whilst driving.**

The seats can also be adjusted:

- Up to 6 minutes after a door is unlocked and before the ignition is switched on.
- Up to 6 minutes after the ignition is switched off.

If the seat operation times out:

- Turn the ignition control on.
- Close or open a door.

Seat Controls

Electric Seat Adjustment

 *The ignition must be on before the lumbar and bolster support can be operated.*

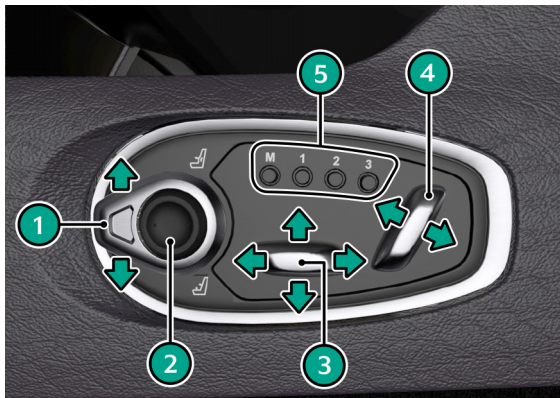

[1] LUMBAR/BOLSTER ADJUSTMENT SELECTOR SWITCH₁: Press the switch up to select lumbar adjustment. Press down to select bolster adjustment.

[2] LUMBAR/BOLSTER ADJUSTMENT: Use the directional pad to adjust the position of the lumbar or bolster support.

[3] SEAT POSITION ADJUST: Seat forward/backward and height adjust₂. Raise front to tilt base of seat.

[4] SEAT BACKREST ADJUST: Seat back angle adjust.

[5] MEMORY SEAT POSITIONS: Use to select or store memory positions for the seat, steering column and door mirror positions.

₁ Optional - Sport Seat Only

₂ Not performance Seat

Manual Seat Adjustment

To move the seats forward or back, pull the strap to unlock the seat.



Seat Back Release

⚠ Caution: Make sure that the headrest for the seat does not hit the sun visor. The seat can cause damage to the sun visor or the sun visor mirror.

Pull the release strap (A) to release the seat back.

Pull and hold to move the rear of the seat forward.



Push the rear of the seat into position to lock it in place.

 A warning message will be shown in the instrument cluster if the seat is not correctly locked back into position.

Headrests

The driver and passenger seats include non-adjustable head restraints, which limit the rearward travel of the head in a rear impact and may reduce whip lash injuries. When sitting in the seats make sure that the seat back is in an upright position and that the rear of the occupant's head is positioned in the centre of the head restraint area. The head restraints are most effective when the distance between the rear of the occupant's head and the head restraint is kept to a minimum.



Windows

⚠ Warning: Misuse of the window switches, especially by children, can result in injury due to entrapment in the window closure. Drivers must advise all passengers of the possible danger and make sure that all obstructions are clear before raising the window.

📖 The windows can be operated up to one minute after the ignition is turned off.

To raise and lower the windows the ignition must be on. Use a window switch on the driver's side (A) or the passenger's side (B) to operate a window.



Press or pull past resistance on the window switch to perform a one-touch movement down or up.

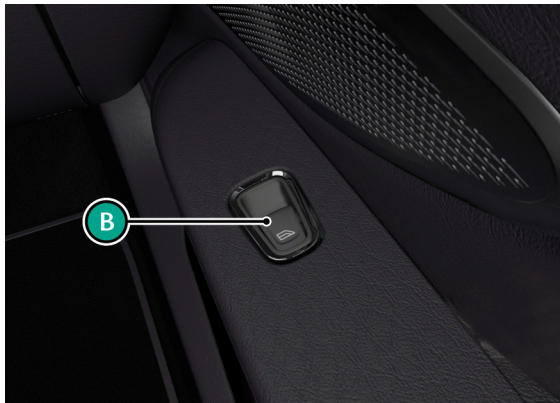

If power to the electric windows has been interrupted for any reason, they will fail to operate correctly until reset.

Door Sealing

⚠ Warning: Make sure that all passengers are clear when the window mechanism is operating.

To minimize wind noise and to make sure that the window seal is watertight, a door sealing system is used to provide a tight fit of the door glass to the seals around the top of the door opening.

The window automatically lowers a small distance to clear the door seal when a door is opened. When the door is closed, the window automatically lifts against the body frame rubber seals.

Window Anti-Trap

The door windows use an anti-trap mechanism to prevent accidental closure of a window on vulnerable parts of the body or other obstructions. When the window motor senses an obstruction, the window stops closing and then opens to release the obstruction.

Mirrors

Interior Mirrors

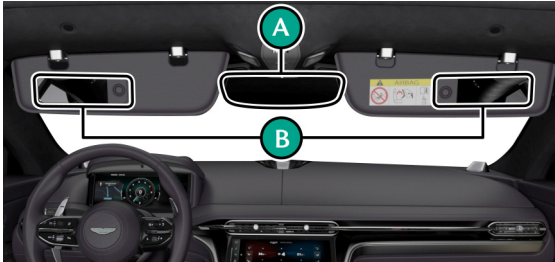

Adjust the mirror (A) on its ball mounting until a satisfactory rear view is obtained.

Automatic Dim

The rear view mirror will dim automatically if the glare from the headlamps of following vehicles becomes too bright. The mirror will return to normal view as unwanted glare reduces to an acceptable level.

Vanity Mirror

A vanity mirror (B) is located in each sun visor. Fold the sun visor down and slide the cover to view the mirror.

Exterior Mirrors

To adjust the exterior mirrors press the mirror switch (A) left or right to select a side to adjust. Move the direction pad (B) up, down, left or right to adjust the selected mirror.



Heated Mirrors

The heated door mirrors will operate when the heated rear window is switched on.

Mirror Fold

To fold the mirrors, press and hold the mirror switch (A) to the left or right.

Auto-Fold

When the vehicle is locked using the vehicle key or master lock switch, the mirrors will automatically fold in. The mirrors will return to the driving position when the vehicle is unlocked.

This function can be enabled or disabled in the systems settings menu (Refer to 'Comfort', page 12.5).

Memory Function

The position of the exterior mirrors is stored when a seating position is saved for the driver's seat.

Reverse Dip Function

To set a position for the reverse dip mirror, use the mirror switch to set a position for the passenger side mirror with reverse gear selected. The mirror will now move to the position when reverse gear is selected, if the driver's side mirror is not selected. If the driver's side mirror is selected the mirror will not move. Select the passenger side mirror to dip the passenger side mirror.

Steering Column

Adjustment

⚠ Warning: Do not adjust the steering column whilst driving.

 The steering column can be adjusted with the ignition set to off.

The reach and tilt angle of the steering column are adjusted with the adjustment stalk. Push the stalk down or up to adjust the steering column angle. Pull the stalk towards you to bring the steering wheel closer and away to move the steering wheel back.



Heated Steering Wheel

 *The ignition must be on before the heated steering wheel can be operated.*

To set the steering wheel heating to on, rotate the end of the adjustment counter-clockwise from you. The indicator LED lamp will also come on.

To turn the steering wheel heating off, rotate the stalk clockwise.

 *The steering wheel heating is always set to off when the ignition is set to off.*

Memory Function

The position of the steering column is stored when a seating position is saved for the driver's seat.

Memory Functions

 **Warning: Make sure that there is nothing in the movement path of the seat or the steering column during adjustment that could cause obstruction.**

 **Warning: To avoid injury, make sure that children do not play with the memory position switches.**

 **Warning: If the seat or steering column accidentally begin to move, press any seat control button to stop the seat.**

 *Lumbar and Bolster positions are not recorded when memory positions are saved.*

The position of the driver and front passenger seats, steering column and exterior mirrors can be memorized and recalled.

Three different driving position profiles can be entered in the memory. The memory position of the steering column and both door rear view mirrors are saved in the driver's seat position.

The infotainment settings will also be saved from the last time each vehicle key was used.

Setting a Memory Position



To Save A Memory Position

⚠ Warning: Do not attempt to adjust the driver's seat whilst driving.

Adjust the seat, steering column and the exterior rear view mirrors to the desired position. Push the memory button (M), then press the required memory channel (1, 2 or 3) to save the positions. A chime is heard to confirm. By repeating these steps and pressing an unused button, a second and third driving position can be saved in the memory.

Recalling a Memory Position

Once in the seat button 1, 2 or 3 (depending on which saved channel is required) until all movement is stopped. The seat will move to the saved position.

Seat and steering wheel movement will be interrupted if the memory channel button is released. Exterior mirror movement will continue. Press and hold the memory channel button to complete seat and steering wheel movement.

Emergency Stop

If the seat accidentally begins to move, press any seat control button to stop the seat.

Occupant Restraint System

The system provides protection to the driver and all passengers in a variety of impact conditions.

The system consists of:

- Driver and front passenger safety belts with dual pre-tensioners and load limiting systems.
- Driver and front passenger dual-stage airbags.
- Driver and front passenger seat side airbags.
- Driver and front passenger roof mounted curtain airbag (coupe).
- Driver and front passenger door mounted curtain airbag (volante).
- Driver and front passenger knee bolster airbags.
- Roll Over Protection System (ROPS) (volante).

All of these systems are controlled by the Occupant Restraint Controller (ORC). In a collision the ORC will analyse information from various sensors, such as crash and seat occupancy conditions. Based on this information the system will deploy the appropriate safety devices. During a crash, the ORC may or may not operate the safety belt pre-tensioner(s) and none, one, or both stages of the dual-stage airbag supplemental restraints.

If the pre-tensioners or airbags do not operate in a collision it does not mean that something is wrong with the system. Rather, it means the system determined the accident conditions (crash severity, belt usage, etc.) were not appropriate to operate these safety devices.

Front airbags are designed to operate only in frontal and near-frontal collisions, not rollovers, side-impacts, or rear-impacts unless the collision causes sufficient longitudinal deceleration.

Determining if the System is Operational

The ORC warning symbol is shown in the instrument cluster  to give the condition of the system. A fault with the system is shown by one or more of the following:

- The warning symbol will flash or stay on.
- The warning symbol does not come on immediately after the ignition is set to on.
- A message will show in the right side instrument cluster window with a description of the fault.

If either of these conditions occur, even intermittently, have the restraint system serviced at your Aston Martin Dealer immediately. Unless serviced, the system may not operate correctly in the event of a collision.

Seat Belts

⚠ Warning: Seat belts should not be worn with straps twisted.

⚠ Warning: Seat belts are designed for adults; infants and smaller children must be restrained in an approved child safety seat.

⚠ Warning: Each belt assembly must only be used by one occupant; it is dangerous to put a belt around a child being carried on the passengers lap. Do not put an adult seat belt around two children.

⚠ Warning: When installed, the seat belt webbing must not contact any sharp edges which could abrade or cut the webbing during normal use or in an accident. If necessary, the webbing must be protected.

⚠ Warning: Care should be taken to avoid contamination of the webbing with polishes, oils and chemicals, and particularly battery acid. Cleaning may safely be carried out using mild soap and water. The belt should be replaced if webbing becomes frayed, contaminated or damaged.

⚠ Warning: Wearing your seat belt is crucial to your safety. Not wearing a seat belt increases chance of serious injury or death in the event of an accident.

⚠ Warning: Be sure that you and your passengers always fasten their seat belts and use them correctly even though airbags are provided.

⚠ Warning: Reclining the seat back decreases protection provided by the seat belt in the event of a crash. Adjust the seat back to an upright position. Make sure that the seat back is locked in place, otherwise it could move forward in the event of a sudden stop or crash and cause injury.

⚠ Warning: Seat belts are designed to bear upon the bony structure of the body, and should be worn low across the front of the pelvis, chest and shoulders; wearing the lap section of the belt across the abdominal area must be avoided.

⚠ Warning: Never place the shoulder portion of belt under your arm or behind your back.

⚠ Warning: Always remove rigid or breakable objects i.e. spectacles or a mobile phone, from your pockets. These items could be trapped under seat belts, possibly causing injury in the event of an accident.

⚠ Warning: Expectant mothers should seek medical advice on the most appropriate way to wear the seat belt.

⚠ Warning: Seat belts must be kept clean so that the retractor works correctly. Make sure that belt webbing is not twisted, looped, frayed or obstructed in any way. If in doubt about condition or operation of seat belt installation, have it checked by your Aston Martin Dealer.

⚠ Warning: No modifications or additions should be made by the user which will either prevent seat belt adjusting devices from operating, or prevent seat belt assembly from being adjusted to remove slack. Never install accessories on your seat belts.

⚠ Warning: Seat belts should be adjusted as firmly as possible, consistent with comfort, to provide the protection for which they have been designed. A slack belt will greatly reduce the protection afforded to the wearer.

⚠ Warning: It is essential to replace the entire seat belt assembly after it has been worn in a severe impact even if damage to the seat belt assembly is not obvious.

⚠ Warning: If it is necessary to replace a seat belt on this vehicle then it **MUST** be replaced with an approved seat belt. The approved seat belts for the front seats must also include a load limiting system.

Pre-tensioner and Load Limiting

Front seat belts are equipped with dual pre-tensioners and load limiting systems.

In most moderate frontal or near frontal accidents, the front airbag and all pre-tensioner systems will deploy simultaneously.

The pre-tensioners take up slack in the seat belts as the airbags are expanding. The load limiting system releases belt webbing in a controlled manner to reduce belt force on a passenger's chest.

 *In some moderate frontal or near frontal accidents, only the pre-tensioner system will deploy.*

Front Seat Belt Reminder

 The seat belt reminder warning symbol in the instrument cluster will come on and warning sound will be heard for six seconds (approximately) when the ignition is set to on if the driver or passenger₁ seat belt is not fastened. (Market dependent.)

If the driver seat belt is not fastened after 60 seconds or if the vehicle has reached a speed of 25 km/h, a warning sound will be heard for 30 seconds, after which the warning sound will go off, but the warning symbol will continue to show until the seat belt is fastened.

Rear Seat Belt Status

If a rear seat belt is unbuckled, regardless of if the rear seat is occupied, a warning will be shown in the instrument cluster to show which seat belts are not buckled correctly. To clear the warning, make sure all rear belts are buckled.



The warning will also be shown at ignition on to test the system. Press OK or wait 60 seconds for the warning to clear.

 *If a belt is unbuckled once the vehicle is in motion, an audible warning will also be given.*

₁. If a passenger is sitting in the front passenger seat.

Seat Belt Fastening

 When parked on an incline, the seat belt may lock as it is withdrawn. This is not a fault. If the mechanism locks, release the belt tension and then pull the belt very gently to avoid operation of the inertia lock.

Each seat has three point, inertia reel seat belts installed. Items 1, 2 and 3 show the three points of the seat belt. Item 3 is also the location of the belt buckle.



The inertia belt reels will automatically tension the belts to provide security with comfort. In the event of a collision or during severe braking, the belt reels will lock.

To test the locking function of the retractor, quickly pull the seat belt forward. If the seat belt does not lock, consult your Aston Martin dealer.

Pull out the seat belt, drawing the buckle over the shoulder and across the chest.



3.16 Before Driving

Push the buckle into the belt buckle latch until a positive click is heard.



Pull upwards on the diagonal belt to make sure that the latching is secure and to remove all slack from the belt. Check that the lap belt is installed snugly, low down across the hips, and that there are no twists.

If it is necessary for a passenger to adjust their seat or seating position during a journey, the belt tension might be disturbed. The passenger should therefore (as soon as it is safe to do so) gently pull down the shoulder run of the seat belt to create some slack and then immediately release it to re-tension the belt for the new seating position.



Seat Belt Unfastening

Push the button on the buckle. While holding the seat belt buckle, allow the belt to slowly retract to its stored position.

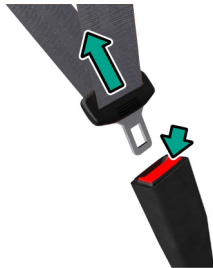

⚠ Warning: Do not allow the belt to twist, or be looped, frayed or obstructed in any way when the seat belt is retracted back into its stowage position.

Airbags

The purpose of the airbags is to provide additional protection for the driver and passengers in the event of a serious impact (front or side impacts). The airbags are supplementary to the seat belts.

Important airbag safety labels are located on the sun visors and on the end of the instrument panel (passenger side). Make sure that the instructions on these labels are read and complied with before driving the vehicle.

The front driver's (A), passenger (B) and knee bolster airbag (C) only deploy in a serious front collision.



3.18 Before Driving

The side airbags (D) located in the front seats and the curtain airbag (E), located in the roof trim¹ or door², only deploy according to which side has been impacted in a serious side collision.





-
1. Coupe Only
 2. Volante Only

Airbag Deployment

 **Warning:** *The use of accessory seat covers may prevent the deployment of the seat side airbags and increase the risk of injury in an accident. Do not use accessory seat covers.*

 **Warning:** *All passengers, including the driver, should always wear seat belts, whether or not an airbag is provided, to decrease the risk of injury or death in the event of a crash.*

 **Warning:** *No objects whatsoever should be attached to, or placed on, the centre cover of the steering wheel or the front passenger fascia panel. Such objects could cause harm if the vehicle is in a collision severe enough to cause the airbags to deploy.*

 *The airbag system is not designed to protect against rear impacts.*

Airbags inflate rapidly and with considerable force; there is therefore a risk of death or serious injury such as fractures, facial and eye injuries or internal injuries, particularly to passengers who are not correctly restrained by seat belts or are not sitting correctly when the airbags deploy. The risk of injury from a deploying airbag is greatest close to the trim panel covering the airbag.

The whole sequence of events from sensing the impact to full inflation of the airbag takes place in a fraction of a second.

Do not change, modify or tamper with the steering wheel, passenger side fascia or any other part of the airbag system. Such actions could disable the system or cause inadvertent airbag deployment.

The system will not deploy in the event of minor frontal or side impacts, such as contacts when parking.

All work on the airbag system must only be carried out by an Aston Martin Dealer.

Child Safety

Aston Martin strongly recommends:

- That all children are sat in the rear passenger seats.
- Always use the Child Restraint Anchorage System (CRAS) where available.
- Only one child seat be installed to the passenger side of the vehicle at any time.
- A child, regardless of age, should always be restrained when travelling in a vehicle.

Your vehicle has the following devices for the installation of child restraints:

- Front passenger seat with Occupant Classification System (OCS) and top tether.
- Rear seat Child Restraint Anchorage System (CRAS) .
- Passenger seat Automatic Locking Retractor (ALR) seat belts.

⚠ Warning: Accident statistics show that children are generally safer when correctly restrained in the rear seat than in the front seat. A suitable child restraint, correctly installed and used, provides the highest degree of protection for infants and small children in most accident situations.

⚠ Warning: Do not allow children to travel in a vehicle without being correctly restrained. An appropriate child seat or harness should always be used.

⚠ Warning: Each seat belt assembly must be used by only one passenger. It is dangerous to put a seat belt around a child being carried on the passengers lap.

⚠ Warning: Make sure that an installed child seat does not rest against the door, that the child sits correctly in the seat and does not lean close to, or against, the door or window.

Child Seat Belt Fastening

⚠ Warning: An infant or child that is not correctly restrained can be seriously injured or killed in a crash. Seat belts are designed for adults; infants and smaller children must be restrained in an approved child safety seat.

Make sure that there is no slack in the webbing and that the restraint installs correctly across the child's rib cage and hips. These are the parts of the body most able to take the force of impact.

The lap strap should pass across the top of the child's thighs, bearing on the pelvis, not on the abdominal area.

Warning Labels

⚠ Warning: Extreme Hazard: NEVER use a rearward facing child restraint on a seat protected by an ACTIVE AIRBAG in front of it. DEATH or SERIOUS INJURY to the Child can occur.

Warning labels are located on both driver and passenger sun visors and on the passenger end of the instrument panel.



[A]: US Variant

[B]: Canada Variant

Occupant Classification System

The Occupant Classification System (OCS) is part of Occupant restraints Control (ORC) System and operates in addition to the restraints system.

OCS is designed to meet the regulatory requirements of Federal Motor Vehicle Safety Standard (FMVSS) 208 to set the front passenger airbag to OFF under certain conditions.

OCS uses capacitive measurement to differentiate between adults, occupied small (1 year old or younger) child restraint seats, and empty seats. Capacitive measurement is not weight sensitive and depends on chemical and physical features to determine if an object or a person is in the passenger seat. This information is then sent to the ORC module.

If OCS determines an adult is in the passenger seat, the passenger airbag will be active.

If OCS determines there is a child restraint seats (CRS) present, or the seat is empty, the passenger airbag will be automatically switched off.

 *If it is necessary to modify the advanced restraints system to accommodate a person with disabilities, contact your Aston Martin Dealer .*





If the front passenger seat is occupied by an adult, the PASS AIRBAG status symbol will be set to  (A).



The passenger airbag will be set to off if:

- The front passenger seat is unoccupied.
- The measured capacitance is less than that of a typical 1 (one) year old infant.

If the airbag is set to off, the PASS AIRBAG status symbol will also be set to  (B).



Passenger Seat	Airbag	Status Symbol
Empty	Off	
Child + Child Seat	Off	 
Adult	On	

 The  symbol will come on for a short period when the ignition is switched on to confirm it is ready.

Warnings

⚠ Warning: *Important OCS components, such as the capacitive sensor and control unit, are installed in the front passenger seat. Suitable precautions must be taken to prevent these components from being damaged. Any damage to the seat trim, such as cuts that have penetrated the trim material, must be inspected by an Aston Martin Dealer. The system must also be checked for corrected functionality. Depending on the level of damage, OCS components may require replacement and the system checked again. OCS functionality cannot be warranted if the seat is damaged.*

⚠ Warning: *To prevent damage to the OCS and other seat components, do not kneel on, or apply concentrated pressure to, the front seats. Do not put sharp items on the seats.*

⚠ Warning: *Never remove the front passenger seat from the vehicle or remove the seat trim. Never dismantle, remove parts off the seat or disconnect wires from the seat. Any incorrect repair or disassembly of the front passenger seat can prevent the OCS from functioning correctly.*

⚠ Warning: *Do not install any additional seat accessories, such as beaded trims or padding, or use cushions, blankets or similar items on the front passenger seat. Additional items such as these may increase the distance between passenger and seat and cause the OCS to incorrectly classify the occupant and give incorrect airbag functionality.*

⚠ Warning: *Use only approved cleaning materials to clean the vehicle interior surfaces. Solvents or other incorrect cleaning products on the surface where the sensor is located (under the leather of the cushion) can damage the sensor.*

⚠ Warning: *Spilt water or steam cleaning the seat can cause the OCS to incorrectly classify a seat occupant. Wait for the seat to dry completely before use. Make sure that there are no wet objects (such as wet towels), water or other liquids on the front passenger seat cushion.*

⚠ Warning: *Do not place objects on the front passenger seat. The capacitive sensor is not a weight sensor, but increased weight on the seat can cause the trim to become thinner and increase capacitance. Objects on the front passenger seat can cause the OCS to incorrectly classify a seat occupant and give incorrect airbag functionality. Always check the airbag status lamp.*

⚠ Warning: Do not charge electrical devices on the passenger seat. This can cause the OCS to incorrectly classify the capacitance as a seat occupant and give incorrect airbag functionality. Always check the airbag status lamp.

⚠ Warning: Do not put shopping bags on the passenger seat. A large amount of liquid, such as bottled water, can cause the OCS to incorrectly classify the capacitance as a seat occupant and give incorrect airbag functionality. Always check the airbag status lamp.

⚠ Warning: Incorrect installation of a child seat may cause the passenger sensing system to leave the front airbag set to on. Always make sure that child seats are correctly installed on the seat. Read the child seat manufacturer's installation instructions.

⚠ Warning: Even with the advanced restraints system, children aged 12 and under should be correctly restrained in the rear seats.

⚠ Warning: Do not hang objects off the front seat backrest if a child is in the front passenger seat.

⚠ Warning: Always check the PASS AIRBAG status symbol for correct airbag status.

⚠ Warning: Any alteration or modification to the front passenger seat may affect the performance of the OCS.

Seating Position

⚠ Warning: Always sit upright against the seat backrest and with both feet on the floor. If you do not sit correctly or with the seat backrest reclined too far this can alter the capacitance read by the OCS and affect the functionality of the front passenger sensing system, resulting in serious injury or death in a crash.

After all passengers have adjusted their seats and put on safety belts, it's very important that they continue to sit correctly. A correctly seated passenger sits upright, leaning against the seat backrest, and centred on the seat cushion, with their feet comfortably extended on the floor. Sitting incorrectly can increase the chance of injury in a crash event. For example, if a passenger slouches, lies down, turns sideways, sits forward, leans forward or sideways, or puts one or both feet up, the chance of injury during a crash is greatly increased.

If a person of adult size is sitting in the front passenger's seat and the PASS AIRBAG symbol is  it is possible that the person is not sitting correctly in the seat.

Child Seat Installation

If this happens:

1. Set the ignition to off. Ask the person to place the seat backrest in the full upright position.
2. Have the person sit upright in the seat, centred on the seat cushion, with the person's legs comfortably extended.
3. Start the engine and have the person stay in this position for about two minutes. This will let the system detect that person and set the passenger's front airbag to on.
4. If the PASS AIRBAG symbol stays  even after this, the person should be advised to sit in a rear seat. (If available)

These conditions can cause the weight of a correctly seated passenger to be incorrectly interpreted by the front passenger sensing system. The person in the front passenger seat can appear heavier or lighter due to the conditions described.

If the PASS AIRBAG symbol stays , this may or may not be a problem due to the front passenger sensing system.

Do not attempt to repair or service the system. Take the vehicle immediately to the nearest Aston Martin Dealer.

Seat Position - Seat Belt Installation

⚠ Warning: Always follow the child seat manufacturer's instructions for correct installation. Not following the child seat manufacturer's instructions when installing the child seat is dangerous.

⚠ Warning: Seat belt installed child restraints are designed to be secured by the lap belt and shoulder portion of the safety belt. Children could be endangered in a crash if their child restraints are not properly secured in the vehicle.

The Automatic Locking Retractor (ALR) system is designed to securely hold child seats. The ALR system temporarily locks a seat belt that is securing a child seat.

ALR Operation

Gently pull out the seat belt until fully extended. The ALR system will only engage at the maximum extension point of the seat belt.

Thread the belt tongue through the child seat as per the child seat manufacturer instructions. Engage the tongue into the belt buckle.

Adjust the tongue position on the belt to make sure that the lower belt run is tight and then allow the upper run of the seat belt to fully retract until the child seat is securely held. The ALR system will be heard 'clicking' as the seat belt retracts.

When fully retracted, pull down on the upper run of the belt to check that the ALR lock has engaged.

 *When parked on an incline, the seat belt may lock as it is withdrawn. This is not a fault. If the mechanism locks, release the seat belt tension and then pull the seat belt very gently to avoid operation of the inertia lock.*

The ALR system will disengage when the seat belt is fully retracted. The seat belt may then be worn when required as a normal seat belt. Once the ALR is disengaged, the seat belt must be fully extended to re-engage the system on the next occasion that a child seat is installed.

Front Child Seat Installation

To install a child seat to the front seat using the seat belt, use the procedure that follows:

1. Move the passenger seat to its fully rearward and highest position. Lower the front of the seat cushion to its lowest position.
2. Recline the back of the seat as necessary.
3. Follow the child seat manufacturers instructions and install the child seat into the passenger seat.
4. Raise the seat back until the child seat is supported by the back of the passenger seat.

Rear Child Seat Installation

Aston Martin do not recommend a child seat is installed to the rear seats of this vehicle with a seat belt.

Rear Child Seat Installation

⚠ Warning: An unsecured child seat is dangerous. In a sudden stop or a collision it could move, causing serious injury or death to the child or other passengers. Make sure the child seat is correctly secured in place according to the manufacturer's instructions.

⚠ Warning: When installing the child seat, make sure that there are no seat belts or foreign objects near or around the ISOFIX anchors. If seat belts or a foreign object prevents the child seat from being securely attached to the ISOFIX anchors, the child seat could move in a sudden stop or collision causing serious injury or death to the child or other passengers.

⚠ Warning: Make sure that the child seat tether strap is always used when installing a child seat with ISOFIX anchors.

Rear Tether Anchors Seats

⚠ Warning: An infant or child that is not properly restrained can be seriously injured or killed in a crash. Seat belts are designed for adults and larger children; infants and smaller children must be restrained in an approved child safety seat.

⚠ Warning: Child restraint anchorages are designed to withstand only those loads imposed by correctly installed child restraints. Under no circumstances are they to be used for adult seatbelts, harnesses or for attaching other items or equipment to the vehicle.

⚠ Warning: Always follow the child seat manufacturer's instructions. Not following the child seat manufacturer's instructions when installing the child seat is dangerous.

⚠ Warning: Make sure the child seat tether strap is free from obstructions above and below. Do not place any items on the tether strap between the child seat and the tether anchor point. Do not place tether strap over any items between the child seat and the tether anchor point.

⚠ Warning: An unsecured child seat is dangerous. In a sudden stop or a collision it could move, causing serious injury or death to the child or other passengers. Make sure the child seat is correctly secured in place according to the manufacturer's instructions.

⚠ Warning: When installing the child seat, make sure that there are no seat belts or foreign objects near or around the CRAS anchors. If seat belts or a foreign object prevents the child seat from being securely attached to the CRAS anchors, the child seat could move in a sudden stop or collision causing serious injury or death to the child or other passengers.

⚠ Warning: Make sure that the child seat tether strap is always used when installing a child seat with CRAS anchors.

This vehicle is equipped with ISOFIX (International Standards Organisation FIX) anchors for the installation of child seats on the rear passenger seats. The anchors are located between the seat base and the seat back. The position of the anchors is shown by two tags at the base of each rear seat.



Remove the lower seat back panel (A).

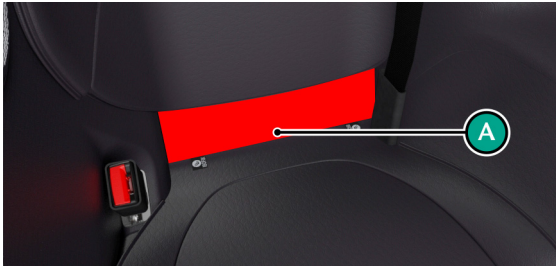

 The seat back trim panels are left and right handed.

Secure the child seat using the ISOFIX anchors (B), following the child seat manufacturer's instructions.

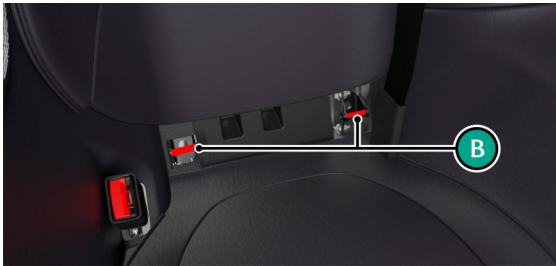

Front Passenger Seat Position

When a child seat is installed to the rear seat using ISOFIX, you must move the seat directly in front of the child seat depending on the size seat being installed.

For Size Class R1 Fixture ISOFIX SEATS:

Coupe Only

1. Move the base of the seat directly in front of the child seat to its fully forward and lowest position.

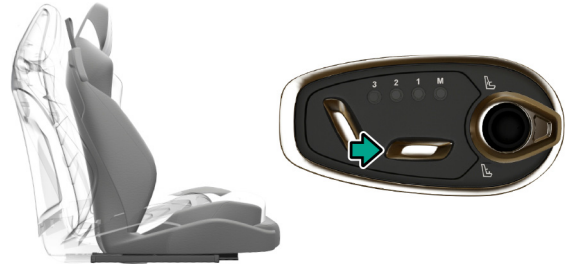

2. Move the base of the seat to its highest position.



3. Adjust the back of the seat to it's fully forward position.

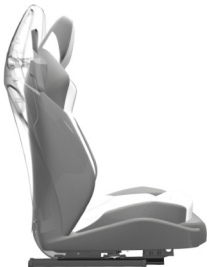

For Size Class F2/F2X Fixture ISOFIX SEATS:

1. Move the base of the seat directly in front of the child seat to its lowest position.

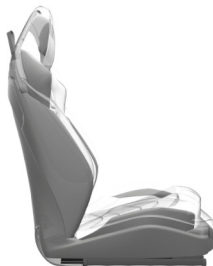

2. Move the base of the seat as far forward as possible.



Cabin Storage

3. Adjust the back of the seat to a fully vertical position.

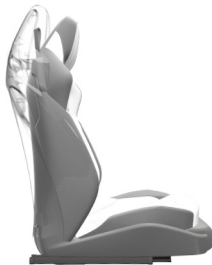

Door Pockets

 Do not use the door pocket to store items that could easily fall out when the door is opened, such as mobile phones or wallets.



Glove Box

⚠ Warning: In the event of heavy braking, sharp steering or an accident, items in the glove box can be thrown into the cabin and can cause injury. Always close the glove box before driving.

Press the glove box button (A) to open. Push up to close.



Centre Storage Box

The centre storage box gives access to two USB-C ports and a 12V accessory power socket.



Variable Load Space

(Volante Only)

This vehicle has a variable load space device installed that, when the convertible roof is raised, increases the available luggage capacity.

Operation

 *The variable load space divider can only be used with the convertible roof in its raised position.*

To open the load space push the handle up. This will provide an increase in storage space of approximately 40 litres / 1.5 Cu Ft. When the variable load space divider is in its raised position, you will not be able to lower the convertible roof.

 *A warning will be shown in the instrument cluster if the roof switch is pressed and the divider is raised.*

To lower the variable load space divider, pull the handle down.

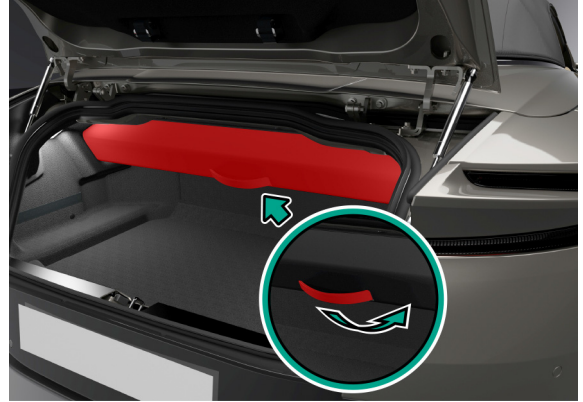

Accessory Sockets

⚠ Warning: *Only connect accessories which are designed for use in a motor vehicle with a 12V electrical system. The electrical system could become damaged if there is more than 10A used from the accessory socket. Always read the manufacturer's instructions and make sure that you do not connect any device which can exceed the rating of the accessory socket.*

⚠ Caution: *Always use the cover for the accessory socket when not in use. Items can get into the socket and cause damage.*

There is an accessory socket located in the armrest storage box in the cabin. This may be used to power any 12 volt vehicle accessory requiring a current of less than 10A.

Ashtray and Cigar Lighter

(Optional)

⚠ Warning: *The cigar lighter will be very hot when in use. Always hold the cigar lighter by the handle and always make sure that the cigar lighter is out of reach of children. Never leave children unattended in a vehicle that has a cigar lighter.*

⚠ Warning: *Do not become distracted while driving, and always be fully aware of all driving conditions. Only use the cigar lighter when road and traffic conditions allow. Failure to avoid potentially hazardous situations could result in an accident or collision resulting in death or serious injury.*

The cigar lighter can be used in the cabin accessory socket when the ignition is on.

Push the lighter down until it clicks. The lighter will pop up when ready for use.

The ashtray installs into the cup holders.

Controls

Instrument Display	4.2
Centre Console.....	4.7
Steering Wheel Controls.....	4.8
Instrument Cluster Menu	4.9
Wiper Controls	4.12
Lighting Controls	4.13

Instrument Display

Instrument Cluster Overview

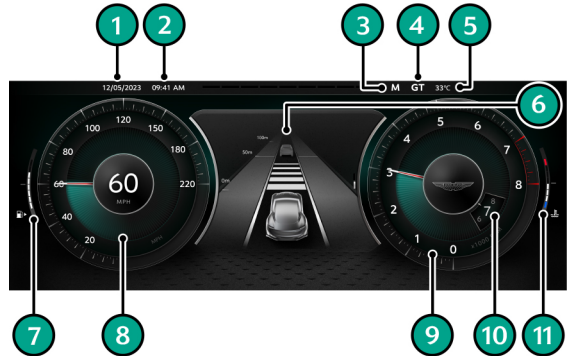
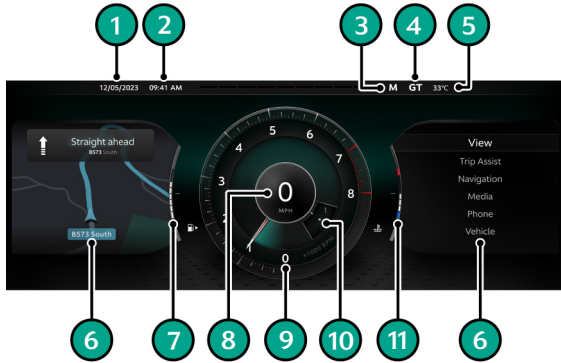

[1] DATE:

Shows the current day, month and year.

[2] CLOCK:

Shows the time.

[3] TRANSMISSION INDICATOR:

Shows the currently selected transmission (Refer to 'Transmission Controls', page 5.5).

[4] DRIVE MODE:

Shows which drive mode the vehicle is in (Refer to 'Drive Modes', page 5.10).

[5] OUTSIDE TEMPERATURE:

Shows the outside temperature.

[6] AUXILIARY SCREEN:

Shows an auxiliary screen for vehicle systems such as ADAS, navigation, instrument cluster menu or audio.

[7] FUEL GAUGE:

Shows how much fuel is left in the fuel tank.

[8] SPEEDOMETER:

Displays vehicle speed.

[9] TACHOMETER:

Shows the engine speed in revolutions per minute x 1000.

[10] GEAR INDICATOR:

Shows selected gear. Also shows when to change up or down a gear in Semi-Automatic and Manual modes (Refer to 'Semi-Automatic Mode', page 5.7).

[11] ENGINE COOLANT TEMPERATURE GAUGE:

Shows the engine coolant temperature.

Information and Warnings

The bottom bar of the instrument display is used to provide warnings and important information for the running of the vehicle.



[1] BATTERY:

The electrical system will do a self-test when the ignition is first turned on. If the warning stays on, or illuminates during driving, there may be a fault with the battery or electrical power system.



[2] MALFUNCTION INDICATION LAMP:



Steady amber shows a fault in the engine management system. Continue driving only if there are no audible, visible or physical signs of degraded engine performance. Consult your Aston Martin Dealer as soon as possible.

Flashing amber shows a major fault in the engine management system. Stop immediately. Contact your Aston Martin Dealer.

[3] LAMP FAILURE:



Shows when a lamp has failed. Have the system checked by an Aston Martin Dealer.

[4] STOP/START SYSTEM:



Shows the status of the stop/start system (Refer to 'Stop/Start', page 5.43).

[5] PARK SENSORS:



Shows when parking sensors are manually turned off (Refer to 'Park Distance Control', page 5.45).

[6] VEHICLE SPEED CONTROLS:



Shows if cruise control is active and set distance to vehicle in front for adaptive cruise control (Refer to 'Speed Control Systems', page 5.14).

[7] LANE ASSIST:



Shows vehicle lane assist status (Refer to 'Lane Assist Systems', page 5.18).

[8] REAR FOG LAMP:



Shows if the rear fog lamp is on or off.

[9] SIDE/DIPPED BEAM HEADLAMPS:

Shows if the side or dipped beam headlamps are active.

[10] MAIN BEAM HEADLAMPS:

Shows the status of the main beam headlamps (Refer to 'Auto Main Beam', page 4.14).

[11] AUTOMATIC EMERGENCY BRAKING:

Shows when active brake assist has detected a potential front collision or if the system has been set to off (Refer to 'Automatic Emergency Braking (AEB)', page 5.32).

[12] ELECTRIC POWER ASSISTED STEERING (EPAS):

⚠ Warning: Do not drive the vehicle if the EPAS warning symbol stays on. Have the system checked by an Aston Martin Dealer.

This symbol shows there is a fault with the EPAS system. Consult your Aston Martin Dealer as soon as possible.

[13] DRIVER ATTENTION ASSIST:

Shows if there is a driver attention warning or a fault with the Driver Attention Assist system (Refer to 'Driver Attention Assist', page 5.23).

[14] SEAT BELT REMINDER:

⚠ Warning: Do not drive the vehicle if the seat belt warning symbol stays ON. Have the system checked by an Aston Martin Dealer.

This warning symbol will come on and a chime will sound for six seconds if the driver's seat belt is not fastened when the ignition is set to on. The chime will continue to operate at different vehicle speeds until the seat belt is fastened¹.

[15] BRAKE WARNING:

(Symbols are market dependant)

If either symbol stays on, there may be a fault with the braking system (Refer to 'Brake Warnings', page 5.30).

[16] ELECTRIC PARK BRAKE (EPB):

Shows when the electric park brake is applied and goes off when fully released.

[17] EPB MALFUNCTION:

Shows if there is a fault with the electronic park brake. A warning message will also show in the instrument cluster. Contact your Aston Martin Dealer as soon as possible.

¹. Market dependant

[18] ABS:

⚠ Warning: If the ABS warning symbol stays on, do not drive the vehicle. Have the system checked by an Aston Martin Dealer.

When the ignition is first switched on, this symbol will briefly be shown whilst the vehicle completes a systems test and then turn off. If this symbol stays on or comes on while driving, there is a fault in the ABS control circuits. Continue driving only if there are no audible, visible or physical signs of degraded brake performance. Consult your Aston Martin Dealer as soon as possible if this symbol stays on.

[19] OCCUPANT RESTRAINT CONTROL (ORC):

⚠ Warning: Do not drive the vehicle if the ORC warning symbol stays on. Have the system checked by an Aston Martin Dealer.

When the ignition is first switched on, this symbol will briefly be shown whilst the vehicle completes a systems test and then turn off. If it does not come on, or if it comes on and stays on, or if it comes on whilst driving, the restraint system has detected a fault.

[20] TIRE PRESSURE:

If this symbol stays on or comes on while driving, a tire or tires' air pressure is below specification.

[21] ELECTRONIC STABILITY PROGRAM (ESP):

When ESP is set to on, this symbol will flash when the ESP is operating. If, while ESP is on, the ESP symbol stays on or it comes on whilst driving, the ESP system has detected a fault. A ESP fault message will show in the message centre. Consult your Aston Martin Dealer as soon as possible.

If ESP has been manually set to off this will be shown in the instrument cluster.

[22] SUSPENSION FAULT:

Shows when there is a fault with the adaptive suspension system.

[23] EXHAUST MODE:

Shows when an exhaust mode other than default is selected.

[24] SUSPENSION MODE:

Shows which suspension mode the vehicle is in (Refer to 'Adaptive Damping', page 5.28).

Centre Console

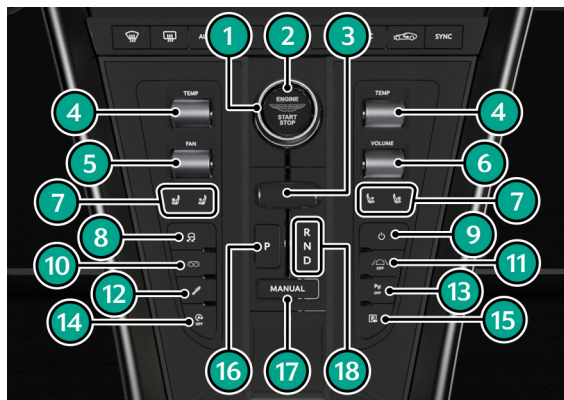

[1] DRIVE MODE SELECTOR: Rotate to select drive modes.

[2] ENGINE START/STOP: Press to start or stop the engine.

[3] TRANSMISSION SELECTOR: Use to select a transmission mode (Refer to 'Automatic Mode', page 5.6).

[4] TEMPERATURE: Adjust the temperature for the climate control.

[5] FAN SPEED: Adjust the fan speed.

[6] VOLUME: Adjust the volume for the audio system. Press to mute audio.

[7] HEATED/COOLED SEATS: Press to change the level of seat heating or cooling.

[8] VEHICLE STABILITY CONTROL: Press to set stability control (Refer to 'ESP Modes', page 5.38).

[9] INFOTAINMENT ON/OFF: Set the infotainment system to on or off.

[10] EXHAUST MODE: Press to cycle exhaust modes.

[11] LANE KEEP ASSIST: Set the lane keep assist to on or off (Refer to 'Lane Keep Assist', page 5.20).

[12] ADAPTIVE DAMPING: Press to cycle adaptive damping modes (Refer to 'Adaptive Damping', page 5.28).

[13] PARK DISTANCE CONTROL: Press to set the Park Distance Control (PDC) sensors to on or off (Refer to 'Park Distance Control', page 5.45).

[14] STOP/START: Use to set the eco stop/start function on or off (Refer to 'Stop/Start', page 5.43).

[15] CAMERA: Changes the infotainment system display to the camera system.

[16] PARK SELECT: Press to select Park.

[17] MANUAL MODE: Press to enter manual transmission mode (Refer to 'Manual Mode', page 5.9).

[18] TRANSMISSION STATUS INDICATOR: Shows selected transmission mode.

Steering Wheel Controls

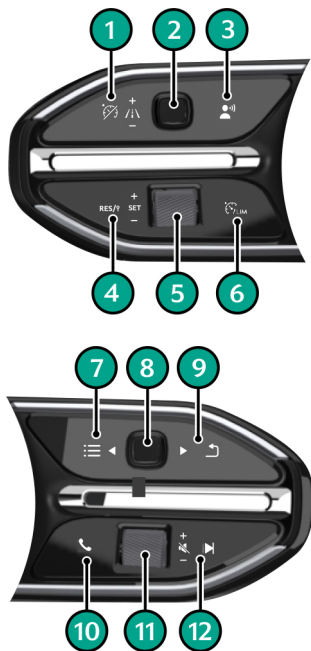

[1] CANCEL:

Tap to cancel the set speed.

[2] ADJUST DISTANCE:

Swipe to adjust the set distance between the vehicle in front and your vehicle during Active Cruise Control (ACC).

[3] START VOICE CONTROL:

Tap to use voice control system for mobile devices.

[4] RES:

Tap to resume a set speed in the speed control systems or adopt a new speed limit in ACC.

[5] SPEED SET SWITCH:

Use the roller dial to adjust the set speed for the ACC or variable speed limiter.

[6] SPEED CONTROL SYSTEM SELECT:

Tap to switch between Adaptive Cruise Control (ACC) and variable speed limiter functions (Refer to 'Speed Control Systems', page 5.14).

Instrument Cluster Menu

[7] MENU HOME:

Tap to open the instrument cluster menu (Refer to 'Instrument Cluster Menu', page 4.9).

[8] MENU SCROLL BUTTONS:

Swipe through the menu to navigate the instrument cluster menu. Press the button to select an item in the menu (referred to in this handbook as **OK**).

[9] MENU BACK:

Tap to go back one level in the instrument cluster menu.

[10] CALL:

Tap to answer an incoming call or open the last dialled number. Press again to end a call or reject an incoming call (Refer to 'Calls', page 7.4).

[11] VOLUME:

Use the scroll wheel to adjust the volume for the audio system. Press to mute audio.

[12] NEXT TRACK:

Tap the to skip to the next audio track.





The instrument cluster includes a secondary infotainment system menu. This menu includes settings for the instrument cluster such as trip computer and units as well as audio and navigation overview screens.



If the cluster is in single dial mode, an item selected to appear in the left screen will not be shown in the menu.

The instrument cluster menu options are:

- Driver Assistance
- View
- Trip Assist
- Navigation
- Media
- Phone
- Vehicle

Use the  button (A) to open the menu home screen. Scroll through the available options with  (B) and select an item by pressing  (also referred to in this handbook as the **OK** button). Press the  (C) to go back a menu level.

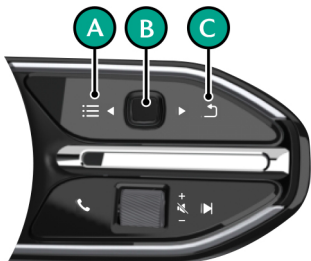

Driver Assistance

Opens the *Driver Assistance* screen which shows an outline of the vehicle with overlays for each various Advanced Driver Assistance Systems (ADAS) function.

- **Adaptive Cruise Control (ACC):** Shows set distance for cruise control and the gap to the vehicle in front, if there is one present (Refer to 'Speed Control Systems', page 5.14).
- **Speed Limiter (LiM):** Shows warnings for if a speed limit for the road changes. Set vehicle speed limit is shown above speedometer display.
- **Lane Keep Assist (LKA):** Shows a warning when a vehicle approaches the edge of the lane, or crosses into another lane, without the relevant indicator used to indicate lane departure (Refer to 'Lane Assist Systems', page 5.18).

- **Blind Spot Assist (BSA):** Shows a warning if there is another vehicle in the driver's blind spot. A secondary warning will be shown if the indicator is also turned on the same direction as the detected vehicle (Refer to 'Blind Spot Assist', page 5.24).
- **Traffic Sign Assist:** Shows information about road signs that have been seen by the vehicle's camera such as road speed and overtaking restrictions (Refer to 'Traffic Sign Assist', page 5.22).
- **Rear Cross Traffic Alert (RCTA):** Shows a warning if there is another vehicle, person or other obstruction appears behind the vehicle when reverse is selected (Refer to 'Rear Cross Traffic Alert', page 5.49).
- **Driver Attention Assist:** Shows warnings if the vehicle has been driven for extended journeys without a break to advise the driver to have a rest (Refer to 'Driver Attention Assist', page 5.23).

View

This menu item is used to set whether the display for the instrument cluster uses a single centre combination dial with two information display windows, or a separate dial for speedometer and a combined tachometer with gear indicator with a single centre information window.

Either format of display also has 3 themes: Light, Dark and Automatic which changes between light and dark depending on light outside the vehicle.

 *The selected theme also sets the theme for the infotainment screen.*

Trip Assist

The trip menu will show journey information about the vehicle. From the trip menu select:

- **Mileage:**
Shows trip mileage and total vehicle mileage.
- **Range:**
Shows available range for the vehicle with the available fuel and an instant rate of fuel consumption. If a navigation destination has been set the distance to the destination will also be shown.
- **Trip Information:**
Shows the distance travelled, journey time, average vehicle speed and average fuel consumption rate.
 - **From Start:** Shows information from when the vehicle journey was started.
 - **From Reset:** Shows cumulative information since the vehicle trip computer was last reset.

Trip Reset

To reset the trip computer values, press and hold  on the steering wheel whilst on the *Mileage* or *Trip Information* screens.

Navigation

Shows the next turn if a route has been set. If no route has been set, shows direction of travel.

Media

Shows the selected media track.

Wiper Controls

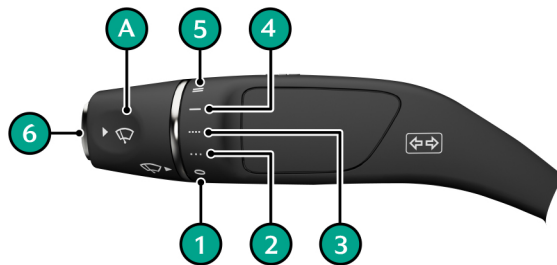

Rotate the wipe speed selector (A) to select a wipe speed.

[1]: Windscreen wipers off.

[2]: Intermittent wipe (low rain sensor sensitivity).

[3]: Intermittent wipe (high rain sensor sensitivity).

[4]: Continuous wipe (slow).

[5]: Continuous wipe (fast).

[6]: Press for single wipe operation. Press and hold further to operate the front windscreen washers.

 At vehicle speeds above 240 km/h (150 mph) the wipers may automatically move to a high park position to reduce aerodynamic load. The wipers will function as normal and return to their normal park position when vehicle speed drops below 4 km/h (3 mph).

⚠ Caution: Set the ignition to on and wipers to off when in a car wash or if the vehicle is being pressure washed. Ignition on will make sure the wiper arms are locked into the park position and will help prevent damage to the wiper arms.

Lighting Controls

Exterior lamps

Master Lamp Switch

Turn the dial to the required light setting. Press the fog lamp button to operate the rear fog lamp.



[1]: Left side park lamp

[2]: Right side park lamp

[3]: Side lamps (including number plate lamps)

[4]: Automatic headlamp mode

[5]: Dipped beam headlamps

[6]: Rear foglamp₁

Exterior lamps (except the side lamps/parking lamps) switch off automatically if you turn the ignition off.

¹ The rear fog lamp will only operate with the headlamps set dipped beam (4) or automatic (5).

Automatic Headlamp Mode

If ambient light fades, headlamps, side marker, rear and registration plate lamps will switch on automatically. If ambient light then increases, headlamps, side marker, rear and registration plate lamps will automatically switch off. Automatic lamps are market specific.

 *The automatic headlamp function features an internal timer that starts when the lamps are turned on. This prevents the lamps from rapidly changing between on and off if situations where ambient light can rapidly change, such as driving between buildings. The headlamps may show a small delay between when a suitable amount of ambient light is detected, and the lamps turning off.*

Auto Main Beam

 **Warning: Auto Main beam is an aid only. The system cannot allow for road, weather or traffic conditions. It is the drivers responsibility to make sure the vehicle's lighting is correct for the driving conditions.**

 *The rain and light sensor may not operate correctly in low visibility or if obscured such as rain, fog, snow or dirt.*

Auto Main Beam is used to automatically switch between main beam and dipped beam when other road users are present¹. The system uses the rain and light sensor to determine the range of other vehicles on the road and will set the headlamps from main beam to dipped beam if there is a vehicle in range. Once the system no longer detects a vehicle, it will set the headlamps back to main beam.

Activating Auto Main Beam

Auto Main Beam is active whenever the main beam headlamps are used and the master lamp switch is set to AUTO. Manually select dipped beam with the wiper stalk, or set the master lamp switch to dipped beam to cancel

Auto Main Beam. When Auto Main Beams are active,  will be shown in the instrument cluster.

¹ The system uses ambient lighting and light from vehicle front and rear lamps to separate parked vehicles and vehicles being driven.

Stalk Controls



Main Beam

Push the stalk away to turn on main beam headlamps. Pull the stalk back to the initial position to return to dipped beam headlamps.

Flash Headlamps

Pull the stalk to flash the main beam headlamps.

Direction Indicators

To briefly indicate, press up to indicate a right turn and down for a left turn. Press until the switch latches to hold the selected indicator on. The stalk will return to the centre position on completion of a manoeuvre.

Hazard lamps

 *The hazard warning lamps will continue to operate if the ignition is switched off.*

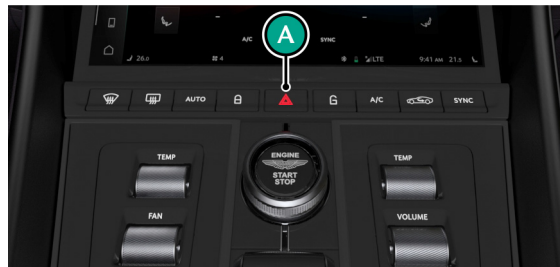

Press  (A) to set the hazard warning lamps to on. All direction indicator signals will flash. Press again to set the hazard warning lamps off.

If you operate a direction indicator from the indicator stalk, only the selected direction indicators will operate. Once cancelled, the hazard warning lamps will resume operation.

Interior Lamps

Instrument Illumination



During the daylight hours the level of instrument brightness defaults to maximum brightness. During the twilight and night time hours, a twilight sensor located at the top of the windscreen automatically reduces the level of brightness to a preset level.

 *If the twilight sensor is covered then the level of brightness will stay low as if in night time mode. For example, when parked in a garage.*

The level of brightness can be reduced by using the illumination dial (A).

Reading Lamps

Two reading lamps are located in the front header trim. To operate the lamps (on or off) touch the reading lamp bezel (A).

Unless set to off or on they will continue to operate up to six minutes after the ignition is set to off.



An additional rear reading lamp can be found in the centre of the rear header.

Driving

Driving Techniques.....	5.2
Multi Purpose Camera.....	5.4
How To Start The Engine.....	5.4
Transmission Controls.....	5.5
Drive Modes.....	5.10
Speed Control Systems.....	5.14
Lane Assist Systems.....	5.18
Traffic Sign Assist.....	5.22
Driver Attention Assist.....	5.23
Blind Spot Assist.....	5.24
Adaptive Damping.....	5.28
Brakes.....	5.29
Electronic Stability Program (ESP).....	5.37
Tyre Pressure Monitoring System (TPMS).....	5.41
Eco Driving Features.....	5.43
Park Assist Systems.....	5.45

Driving Techniques

Procedures for driving this vehicle may be unfamiliar to many new owners. To make sure that you have a safe and enjoyable entry into this new phase of Aston Martin motoring, please take time to safely acquire the necessary new driving skills. Practice in safe, lower speed conditions before investigating the high performance potential of the vehicle.

Driving behaviour, such as avoiding aggressive driving, travelling at lower speeds, correctly inflating tires, reducing periods of idling and not carrying excessive weight, will improve fuel consumption and reduce CO2 emissions.

Performance Driving Courses

Performance driving courses are available to enable you to fully understand the control functions of your vehicle and also the basic principles of performance driving. Contact your Aston Martin Dealer for further information.

Running-In

This vehicle is fully hot tested during manufacture and no special running-in procedures are necessary. Nevertheless it is recommended to limit engine loads (e.g. by accelerating gently and by using lower gears on steep hills or when negotiating tight turns) during the first 1500 km/900miles.

Track Days

Before using this vehicle on track days contact your Aston Martin Dealer for vehicle set up, service parts and recommendations.

Wet Conditions

When driving in wet conditions, water can build up under your tires so that they ride on a layer of water. This is called aquaplaning or hydroplaning. When this happens, you have little or no control. Aquaplaning is more prone to happening at higher road speeds if there is a lot of water on the road and particularly if the tires are also under inflated or approaching minimum tread depth.

It is important to take bends or curves at a safe, reasonable speed, particularly when driving on wet or slippery road surfaces.

Slow down when it is raining.

Tire Skip At Low Speed

In certain conditions, the front tires may 'skip' at low speeds with summer tires installed when a high level of steering lock is applied. This is a characteristic of the vehicle and does not affect the safety or performance of the vehicle.

Brakes in Cold Weather

At low temperatures (below 0°C) moisture within the brake pads may freeze and cause the brake pads to stick to the brake rotors. Additional torque may need to be applied when the vehicle is first used after extended periods of being parked, and there may be a noise as the brake pads become free. Once released, the brakes will operate as normal.

Driving Through Deep Water

If in any doubt whether to drive through deep water, always take the side of caution to avoid potentially costly damage to the vehicle's engine or other essential systems.

⚠ Caution: Never drive in water deeper than the lower edge of the front bumper. Water can be splashed up into the engine air intakes located in the front upper grille and cause extensive damage to the engine or the vehicle may stall. Always proceed with extreme caution, especially when the depth is not known.

When driving through water, traction or brake capability may be limited. Once through the water, always dry the brakes by driving slowly while applying light pressure on the brake pedal.

 *Waves caused by other vehicles or natural causes can also splash water in the engine air intakes.*

Multi Purpose Camera

The Multi Purpose Camera (A) is mounted at the top of the windscreen and is used to give external information to a number of driving systems in the vehicle.



To make sure that these additional driving systems function correctly, the area of the windscreen in front of the camera should be kept clean. The camera is under the swept area of the wiper blades, so will be cleaned as the wipers are used in poor weather. In long dry periods such as in summer, the windscreen wipers should be used periodically to prevent build up of dirt and dust.

How To Start The Engine

⚠ Warning: *The engine can be started by any person in the vehicle if the brake pedal is pressed down. Care should be taken that the vehicle is not left unattended with the key present and occupants such as young children inside.*

⚠ Caution: *In extreme low temperatures (-20°C and below) do not run the engine above 4000 rpm, while at standstill or when moving off, until the coolant temperature gauge reaches normal operating temperature. If you do, there is a risk of damage to the engine and transmission.*



⚠ Caution: Make sure the park brake is applied and the transmission is in **PARK (P)**.

This will prevent the vehicle from moving once the engine is started.

To start the engine, fully press the brake pedal down and press **START/STOP** (A).

Once the engine begins to crank, release **START/STOP**.

Stopping The Engine

Press **START/STOP** to stop the engine.

Transmission Controls

The automatic transmission has three main driver modes:

- **Automatic Mode:**
Transmission is controlled automatically without driver input.
- **Semi-Automatic Mode:**
Gear changes can be controlled with the gearshift paddles behind the steering wheel. The vehicle will change gears when required.
- **Manual Mode:**
Gear changes are only controlled by the gearshift paddles behind the steering wheel and the vehicle will not perform gear changes.

Automatic Mode



In *Automatic* mode, drive modes are selected with the transmission selector lever (A) on the lower console. While driving forward, gearshifts are made automatically according to various driving parameters such as road speed, current selected gear and accelerator demands. When the vehicle is stationary, the transmission will select first gear, ready to move off immediately when the accelerator is pressed.

Reverse (R)

When reverse is selected, the infotainment screen will change to show the reverse camera display.

Neutral (N)

Select to engage Neutral gear.

⚠ Caution: Do not change from Park or Neutral into Drive or Reverse at high engine speed. Doing so can damage the transmission or the engine.

Drive (D)

Select to engage forward gears.

Park (P)

Press the Park switch (B) when the vehicle is stationary. The transmission will mechanically lock.

⚠ Caution: Always make sure that the park brake is on when Park (P) is selected. This will help to make sure the vehicle will not roll.

 It is not possible to select Park above 2 km/h (1 mph).

Kick-Down

In *Automatic* mode, kick-down is used in circumstances where rapid acceleration is required, such as overtaking. Kick-down operates when the accelerator pedal is quickly and fully pressed, causing the transmission to change down to the lowest gear possible to achieve maximum acceleration. The gear engaged depends on the road speed at the time of kick-down.

Semi-Automatic Mode

In *Semi-Automatic* mode, forward gear changes are made with the paddles located behind the steering wheel. If engine speed gets too high or low, the transmission control module will automatically make gear changes.

While in *Semi-Automatic* mode, move to *Automatic* mode at any time by pulling and holding the upshift (+) paddle until Drive is selected.

Pull back on either the upshift (+) or downshift (-) paddle to enter *Semi-Automatic* mode. As the vehicle speed increases and decreases, make upshifts and downshifts by pulling and releasing the upshift or downshift paddle.

If no gearshift has been requested by pulling back on a paddle, upshifts will occur automatically depending on the drive mode as the engine speed rises or lowers to its maximum or minimum operating limits.

If driving in a high gear, pull and hold the downshift paddle to select the lowest available gear. For example, if in sixth gear then second gear is selected.



[1]: Downshift Paddle.

[2]: Upshift Paddle.

Gear Shift Indicator

The instrument cluster shows the actual gear currently selected R, D1, D2, etc and the target gear when a gearshift is in progress.

The instrument cluster will also show an up arrow to indicate when a gear change should take place to obtain better fuel economy. For example, when in seventh gear and a higher gear needs selecting, 7[^] is shown.

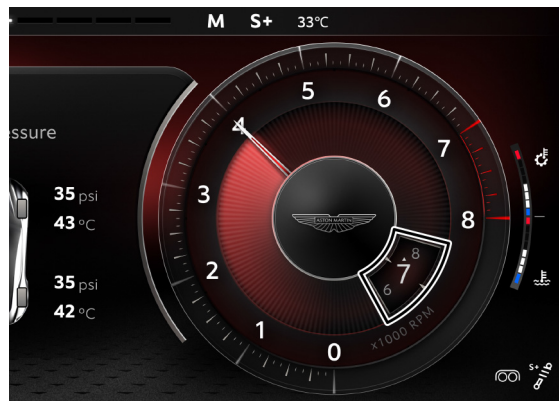

Manual Mode

 To protect the engine, the transmission will automatically drop to 1st gear when the vehicle is brought to a stop.

 Pulling and holding a shift paddle will not return the transmission to Automatic Mode.

 When the ignition is set to off, the transmission will revert back to Automatic Mode.

 The transmission will automatically make a change from 1st into 2nd gear.

Manual mode operates similar to Semi-Automatic mode, except the transmission will no longer automatically change gear as engine speed approaches maximum speed. The transmission will also not revert to automatic mode after a set period of time. To select Manual mode, press the Manual switch (A). Press the switch again to leave Manual mode.



Shift Lights

Whilst in manual mode, shift lights will be activate at the top of the instrument cluster. The shift lights will be added from left to right as engine speed increases.

Drive Modes

Vehicle driving characteristics, such as gear changes and throttle response, can be changed by selecting different drive modes.

Five drive modes are available. Rotate the dial (A) to cycle between:

- Wet
- GT (default)
- Sport
- Sport+
- Individual



The selected mode will be shown in the top of the instrument cluster (B).

 *Drive modes operate independently of Electronic Stability Program (ESP) and Adaptive Damping System (ADS) modes.*

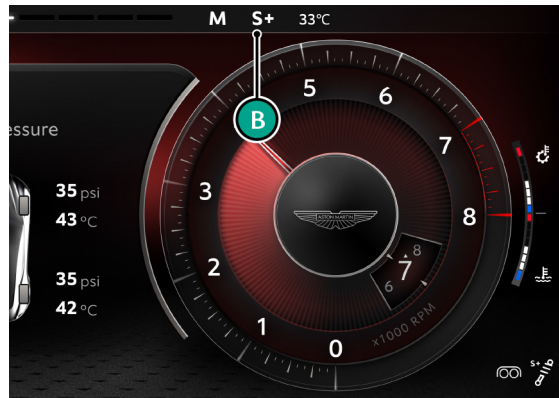

Wet Mode

Wet mode sets the vehicle up to a similar calibration to *GT* but more suitable for driving in adverse conditions. ESP is set to a specific wet road tune to maximize grip and the engine map is also set to a unique calibration to provide predictable power delivery and smooth gear changes.

Wet mode sets the vehicle up to a similar calibration to *Sport* but more suitable for driving in adverse conditions. ESP is set to a specific wet road tune to maximize grip and the engine map is also set to a unique calibration to provide predictable power delivery and smooth gear changes.

Default Settings

Parameter	Setting
Suspension:	GT
Steering:	GT
ESP:	Wet
Powertrain:	Wet
Stop/Start:	On
Exhaust:	GT

GT Mode

GT mode provides a default comfort setting, better suited to casual and motorway driving.

The vehicle is set to use a base engine and transmission calibration to suit a touring style of driving with ESP set to a default setting for normal road use.

Stop/Start functions are available to improve fuel economy.

Default Settings:

Parameter	Setting
Suspension:	GT
Steering:	GT
ESP:	On
Powertrain:	GT
Stop/Start:	On
Exhaust:	GT

Sport Mode

Sport mode uses a more aggressive transmission calibration, but still with a level of comfort when changing gear.

The vehicle now uses a more aggressive calibration, yet still comfortable enough to be used for general driving. Throttle response is also increased with and the exhaust bypass valves operate at lower engine speed to give a sense of increase driver involvement.

Suspension is firmer and steering weight is increased by default to match the vehicle dynamics to the powertrain calibration.

The *Stop/Start* function is available to improve fuel economy.

Default Settings:

Parameter	Setting
Suspension:	Sport
Steering:	Sport
ESP:	On
Powertrain:	Sport
Stop/Start:	On
Exhaust:	Sport

Sport+ Mode

Sport+ mode further increases transmission and engine response over what is used in *Sport* mode. The exhaust bypass valves also revised to open at lower engine loads and speed. The suspensions is made even firmer but the steering has the same increased weighting used in *Sport* mode.

Stop/Start is disabled in *Sport+* mode by default.

Default Settings:

Parameter	Setting
Suspension:	Sport+
Steering:	Sport
ESP:	On
Powertrain:	Sport+
Stop/Start:	Off
Exhaust:	Sport+

Transmission Temperature Gauge

Sport+ mode also adds a transmission temperature gauge (C).

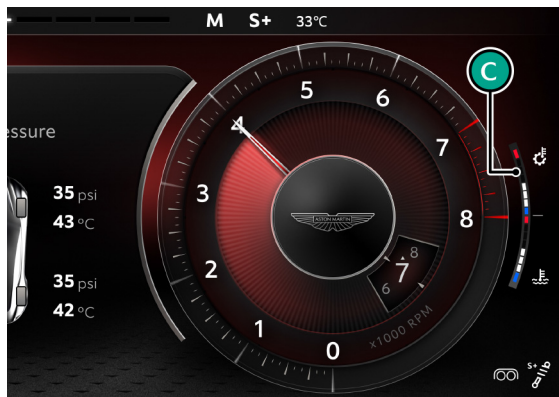

Individual

Individual mode is a custom setting with each parameter set by the driver.

To set *Individual* mode, rotate the drive mode dial in the centre console to **Individual** and select **Personalize**.¹

Select from:

Powertrain

Drive:	Wet	GT	Sport	Sport+
Exhaust:	GT	Sport	Sport+	

Drive Dynamics

Steering:	GT	Sport	
Suspension:	GT	Sport	Sport+

¹ If Individual mode parameters have already been set, **Personalize** will change to **Edit**.

Speed Control Systems

⚠ Warning: Only use ACC or the variable speed limiter if road and traffic conditions are appropriate for maintaining a steady speed for a prolonged period. If you do not, the vehicle may cause an accident or collision resulting in death or serious injury.

⚠ Warning: Both ACC and the variable speed limiter are aids and cannot take into account road, weather or traffic conditions. The driver is always responsible for vehicle speed, braking, controlling the distance to any vehicle(s) in front and for staying in the correct lane.

 Active Brake Assist and Adaptive Cruise Control are disabled when ESP is set to Off.

The speed control systems for the vehicle are made up of two main user selectable systems:

- **Variable Speed Limiter**
Used to set a manual speed limit for the driver.
- **Adaptive Cruise Control (ACC)**
Used to set the vehicle to a set speed which can adapt to the road conditions around it.

ACC and Variable Speed Limiter Controls

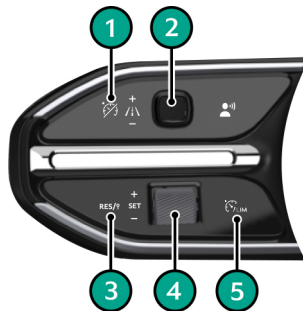



[1] CANCEL: Tap to cancel the set speed.

[2] ADJUST DISTANCE: Swipe to increase or decrease the set distance between the vehicle in front and your vehicle when ACC is active.

[3] RESUME: Tap to resume the set speed, or set the speed to the speed limit detected by the Traffic Sign Recognition system.

[4] SPEED SET DIAL: Use the roller dial to increase or decrease the set speed.

[5] ACC/LIM SELECT: Tap to switch between ACC 

and variable speed limiter  functions.

Setting A Speed

Scroll the speed selector dial (4) up to increase speed, or down to decrease speed in 2 km/h (1 mph) increments. Pressing the switch in either direction will set a new vehicle speed in the cruise control or new vehicle speed limit.

Once a speed has been set, this will be shown above the vehicle's speed in the instrument cluster.

Resuming the Set Speed

 Warning: Set speed should only be resumed if the driver is aware of the set speed and intends to return to it.

Press  (3) to resume the set ACC speed or variable speed limit.

If the ACC is deactivated, or the brake pedal is pressed, ACC will disengage but the set speed memory will be kept. Press the speed selector switch again and the vehicle will return to the set speed.

Variable Speed Limiter

The variable speed limiter brakes automatically so that you do not exceed the set speed. This feature is an aid only and cannot take into account road, weather or traffic conditions. You are responsible for vehicle speed, as well as braking in good time and for staying in the lane.

 *The variable speed limiter operates up to 180 km/h (112 mph).*

Deactivation

 *Set speeds will also be cleared when the ignition is set to off.*

Press  to deactivate the variable speed limiter. Any set speed will also be cleared if ACC is selected.

ACC with Speed Limiter Adaption

Operation

⚠ Warning: ACC may not always be able to differentiate vehicles when they become stationary from static obstacles. To help prevent collisions, ACC should be avoided in heavy traffic.

ACC can be used to maintain a selected vehicle speed without having to use the accelerator and maintains a set distance between your vehicle and the vehicle in front of you.

 ACC operates up to 180 km/h (112 mph).

The ACC system should not be used when:

- road and traffic conditions do not allow you to maintain a constant speed, such as heavy traffic or on winding roads.
- driving on smooth or slippery roads. Braking or accelerating can cause the drive wheels to lose traction and the vehicle could then skid.
- visibility is poor, such as fog, heavy rain or snow.

Setting a Distance Between Vehicles in ACC

⚠ Warning: ACC does not compensate traffic, road or weather conditions. The driver is responsible for vehicle speed and braking in emergency situations. Do not use ACC in conditions that do not permit a constant speed such as heavy traffic, winding roads or slippery roads due to weather conditions.

The ACC system will maintain a set distance from the vehicle in front. If the vehicle begins to brake, your vehicle will also slow down to match, and increase speed to match up to the speed set in the cruise control. The distance between the two vehicles can be set with the distance controls (2).

 The ACC system may not be able to detect narrow vehicles such as motorcycles or vehicles driving on a different line. Detection of obstacles can also be affected by dirty or obscured sensors.

Speed Auto-Resume

If your vehicle comes to a stop as a result of the vehicle in front of you stopping with ACC active, it can automatically resume speed if the vehicle in front drives off again within 3 seconds. If your vehicle is stationary for more than 3 seconds, press  or the accelerator pedal to resume ACC.

Speed Limit Adaption

 *The speed limit adaption does not limit the speed of the vehicle, but adapts the set speed for the ACC to suit the speed limit of the road. The driver can always vary the speed of the vehicle with through the accelerator pedal.*

ACC can adapt its set speed to match the speed limit of the road if one is detected by the Traffic Sign Assist system. This can be done manually or automatically when the vehicle is driven into an area with a change in speed limit.

- **Manual Operation:**

When the vehicle is driven into an area with a new

speed limit, a pop up window will be shown. Press  to set the cruise control to the new speed limit.

- **Automatic Operation:**

When the vehicle is driven into an area with a new speed limit, the vehicle will automatically adapt the speed limit for the road.

To set ACC to manual or automatic mode, (Refer to 'Adaptive Cruise Control', page 12.3).

Deactivation

 *Set speeds will also be cleared when the ignition is set to off.*

Press  to deactivate ACC.

ACC will automatically deactivate when:

- The brake pedal is pressed.
- The park brake is applied.
- Neutral, Park or Reverse gear positions are selected.
- The traction control system is activated.
- The variable speed limiter system is activated.
- A fault occurs in the ACC system. The system will not operate until the fault is cleared.
- ESP is set to Off.

Lane Assist Systems

Safety Warnings

⚠ Warning: The lane assist systems may not always be able to correctly detect lane markings and it is possible it may give incorrect warnings. These systems are an aid only and does not replace the need for driver awareness. It is the driver's responsibility to be aware of their surroundings. Always make sure that there is a suitable distance to the side of your vehicle for other road users and obstacles.

⚠ Warning: The lane assist systems cannot allow for road, traffic and weather conditions. The driver is responsible for the vehicle speed, braking in good time and staying within their lane.

 Lane assist systems are only available at speeds between 60 km/h (37 mph) and 180 km/h (112 mph).

The lane assist system uses the multi purpose camera to detect lane markings in front of the vehicle, and is split into systems that increase in level of assistance offered:

- Lane Departure Warning.
- Lane Keep Assist.





System Limitations

Lane Keep Assist may not function correctly in the below conditions:

- The area around the multi purpose camera is dirty, damaged or otherwise covered.
- There is a short distance to the vehicle in front.
- There are lots of lane markings that change quickly such as, merging or crossing lanes.
- The road is very narrow and winding.
- There are no lane markings or the markings are unclear in the lane, such as when the lane markings are worn away, a mix of old and new markings or many colour changes in road surface.
- Weather conditions such as snow, rain, fog or spray which can cause low visibility or hide road markings. This can also include reflective roads surfaces due to rain.
- Glare into the multi purpose camera from the sun or other road users' headlamps.

System Status

The status of the lane assist systems is shown at the bottom of the instrument cluster:

- **Grey:** System is active but no lane markings have been detected. 
- **Full Green:** System is active and valid lane markings have been detected. 
- **Green with Red Marker:** System is active and has detected the vehicle has crossed a lane marker. The line shown in red represents which lane has been crossed. 
- **Amber:** System has a fault and is not available. Contact your Aston Martin Dealer. 
- **White:** System has been manually deactivated. 

Lane Departure Warning

 *This warning can occur earlier, for example if you begin to approach the other lane marking when on a bend or are on wider lanes such as a motorway.*



If one of the front wheels passes over a lane marking, Lane Departure Warning will first warn if you leave your lane with a vibration through the steering wheel and a warning on the instrument cluster. If you do not react to the warning, the vehicle will escalate to Lane Keep Assist to briefly brake a corner of the vehicle to pull the vehicle back into the correct lane.

Lane Keep Assist

⚠ Warning: Lane Keep Assist cannot always cause the vehicle to move back into its lane. Acceleration, steering and brake input should always be completed by the driver.

⚠ Warning: Lane Keep Assist does not allow for other road users and cannot detect traffic conditions. In some circumstances, the system may steer when not needed, such as driving over a solid lane marking or pulling out past an obstruction. Corrective steering in these circumstances can be interrupted by gently steering in the opposite direction. Always make sure that there is enough space for other traffic.

📖 Lane Keep Assist will only happen once for each time the vehicle leaves its initial lane. Additional corrective steering will not happen again until the vehicle has returned to its initial lane.

If the vehicle continues to pass over the lane markings, Lane Keep Assist will make the vehicle briefly steer to one side to help move the vehicle back to its initial lane. If this corrective steering happens, a warning icon will be shown in the instrument cluster. For the system to operate, lane markings must be on both sides of the vehicle.

Lane Keep Assist will not happen in the below conditions:

- There is clear and deliberate steering, braking or acceleration input.
- A turn indicator is switched on.
- The TPMS has detected a fault with a tire.
- The traction control system is activated.
- The transmission is not in D (Drive).
- An obstruction has been detected in your lane.
- Corners are taken at high speeds or high rates of acceleration where sudden brake application could unbalance the vehicle.

To override Lane Keep Assist intervention:

- Activate the turn indicator.
- Apply the brakes.
- Accelerate.
- Gently steer in the opposite direction.

System Deactivation

Lane Keep Assist

 *The Lane Keep Assist is set to on by default.*

 *When Lane Keep Assist is disabled, this does not disable Lane Departure Warning.*

To deactivate Lane Keep Assist, press the  button (A).





Lane Departure Warning

Lane Departure Warning can only be disabled in the vehicle settings menu (Refer to 'Lane Keep Assist', page 12.4).

 will be shown in the instrument cluster when both Lane Keep Assist and Lane Departure Warning have been deactivated.

Traffic Sign Assist

 *Traffic Sign Assist is an aid only. Traffic Sign Assist may not always be able to correctly display road restrictions. It is the drivers responsibility to be aware of the traffic signs and restrictions for the road being driven on. Traffic signs always take precedent over the display from Traffic Sign Assist.*

 *The Traffic Sign Assist system works with the navigation system to determine the road speed limit.*

The Traffic Sign Assist function shows maximum permitted speeds for the road in the instrument cluster. The system will also give indication of any overtaking restrictions and give a warning if the vehicle is driven down a one way street the wrong way. When you drive past a traffic sign that applies to the road you are on, this information will be updated in the instrument cluster.

The Traffic Sign Assist display will update without a visible traffic sign when you change roads such as joining another road that has a different speed limit. This will be accompanied by an audible beep and the speed will flash to show the change in road speed. If vehicle speed exceeds the stated speed for a road, an audible warning will be given.

If Traffic Sign Assist cannot determine a maximum permitted speed for the road, no speed limit is shown in the instrument cluster.

 *If a traffic sign is passed that gives the end of a road restriction, such as a speed limit, this information is shown for five seconds. Applicable traffic regulation will continue to be shown in the instrument cluster.*

Additional Restrictions

Traffic Sign Assist is capable of detecting traffic signs that have additional restrictions such as alternative speed limits in wet conditions.

Additional restrictions will only be displayed if there is a regulation that must be followed with the restriction, or Traffic Sign Assist is cannot correctly determine if the restriction is in effect.

Traffic Sign Settings

For settings for Traffic Sign Assist (Refer to 'Traffic Sign Assist', page 12.3).

System Limitations

Traffic Sign Assist may not function correctly in the below conditions:

- The area around the multi purpose camera is dirty, damaged or otherwise covered.
- The traffic signs are hard to detect due to insufficient lighting or obscured by dirt, ice, snow etc.
- Weather conditions such as snow, rain, fog or spray which can cause low visibility or hide road signs.
- Glare into the multi purpose camera from the sun or other road users' headlamps.
- The traffic signs are unclear or obscured, such as signs on construction areas.
- The information in the navigation system is incorrect and requires an update.



Driver Attention Assist

⚠ Warning: Driver Attention Assist is for aid only and does not replace the need for driver awareness. It is always the driver's responsibility to be aware of their surroundings and make sure to take break if necessary.

Driver Attention Assist is a function to help driver focus on extended road journeys. Driver Attention Assist regularly looks for signs of fatigue or lapses in concentration and will suggest to take a break.

The below information is shown in the Driver Attention Assist screen in the instrument cluster:

- The time since a break was last taken during the journey.
- The level of attention determined by Driver Attention Assist:

 *If Driver Attention Assist cannot calculate an attention level or show a warning, a message will be shown in the instrument cluster and  will be shown.*

When the vehicle is driven for a continuous period of time, a pop up window will be shown and a warning symbol

 in the instrument cluster.

System Limitations

 Driver Attention Assist is always enabled when the vehicle is driven at speeds of 70 km/h (43 mph).

There are certain scenarios where Driver Attention Assist may not operate or have a delay in providing notifications, such as:

- If the vehicle has been driven for less than 30 minutes.
- Poor road condition such as potholes or uneven road surfaces.
- Enthusiastic or sporty driving style such as high cornering speeds or sharp acceleration.
- Frequent lane changes and changes in speed.

Driver Attention Assist is reset when resuming a journey in the below conditions:

- The vehicle ignition is switched off.
- The driver's seat belt is unbuckled and the driver's door is opened.



Blind Spot Assist

 **Warning:** Blind Spot Assist is for visual aid only and does not replace the need for driver awareness. It is the driver's responsibility to be aware of their surroundings and make sure it is safe to complete a lane change. Always make sure that there is a suitable distance to the side of your vehicle for other road users and obstacles.

 **Warning:** The Blind Spot Assist system can not react to vehicles which approach and overtake you at a greatly different speed. In these situations, the Blind Spot Assist system cannot provide warning to drivers. Always pay attention to the road traffic around you.

Blind Spot Assist is used to help a driver know if a vehicle is in their blind spot so that a lane change action can be safely completed.

The BSA system uses two rear-facing radar units to monitor the area up to 3.5 m (12 ft) behind your vehicle and 3 m (10 ft) directly next to your vehicle.

If a vehicle is detected at speeds above approximately 30 km/h (18 mph) and enters the monitoring range directly next to your vehicle,  will illuminate amber in the exterior mirror. If a vehicle is detected close to your vehicle in the lateral monitoring range and you switch on the turn signal indicator in that direction  will flash in the outside mirror. If you overtake a vehicle quickly, no warning is given.

 *The system can not monitor vehicles when driving around curved roads.*

Operation Conditions

For the Blind Spot Assist system to operate the below conditions must be met:

- Transmission must be in D (Drive).
- The vehicle must be moving at more than 30 km/h (18 mph).
- Vehicles in the blind spot area must be travelling at speeds of:
 - more than 5 km/h (3 mph).
 - between 5 km/h (3 mph) slower and 35 km/h (22 mph) faster than your vehicle.
- The minimum width for a vehicle to be detected is 0.7 m wide (a motorcycle for example).

 *If the BSA system detects a vehicle that is approaching fast enough to be in the blind spot, it will include this in its detection range.*

System Limitations

The BSA system can be limited in its operation in the below situations:

- The sensors are dirty or obstructed such as snow or mud on the bumpers.
- Poor visibility weather conditions (snow, fog, heavy rain etc).
- Warnings may be incorrectly displayed near to crash barriers or long solid barriers.
- Warnings can be interrupted when driving alongside long vehicles such as vehicles with long trailers.

System Activation

The BSA system can be activated or deactivated in the infotainment system/vehicle settings (Refer to 'Blind Spot Assist', page 12.3).

Blind Spot Warnings

Stage One Warning

When the BSA system detects a vehicle in the driver's blind spot area,  will be shown in the bottom outer corner of the door mirror.



Stage Two Warning

The BSA system will be set to stage two if:

- A vehicle is detected in the blind spot area.
- The indicator is used to signal movement into that lane.

When this happens, the below actions will take place.

-  will flash in the door mirror.
- A warning will show in the instrument cluster (changes for direction of lane change).



Door Exit Warning

 *Door Exit Warning is available when the vehicle is stationary and the transmission is in P (Park) or D (Drive). The feature operates up to 3 minutes after the engine is switched off.*

The Door Exit Warning function is a subfunction of the BSA system and detects if a vehicle or bicycle is passing that may come into contact with the door when it is opened.

When the door is opened¹ the BSA radars will check for any approaching vehicles. If there is a risk of collision, then an audible warning will be heard as the door is opened. In

addition, if a front door is opened then  will be illuminated in the door mirror.

Fault Conditions

In the unlikely event of a fault in the BSA system, a warning message will also show in the instrument cluster. Contact your Aston Martin Dealer.

¹. Opened is classed as when door ajar switch is activated and the interior lamps are switched on.

Adaptive Damping

The Adaptive Damping System (ADS) uses sensors to continuously monitor vehicle body movement and driver inputs, such as steering, braking and throttle input. The system then adjusts the suspension damping characteristics to suit the conditions.



Three adaptive damping modes are available. Press the

 button (A) to cycle between:

- GT (Default setting)
- Sport
- Sport+

 ADS will be set to GT mode at each ignition on.

 ADS modes operate independently of Electronic Stability Program (ESP) and drive modes.

If ADS is changed from GT, this will be shown in the right side of the instrument cluster.

GT

GT mode provides a default comfort setting for the suspension, suitable for everyday use.

Sport

Sport mode changes the damping characteristics with increased body control and a firmer ride. Steering weight is also increased to enhance steering response and feedback.

Sport+

Sport+ mode further increase the stiffness of the damping, more suitable for track focused driving.



Brakes

Footbrake

The footbrake uses a vacuum boosted, dual (diagonal split) circuit hydraulic system with Anti-lock Brake System (ABS).

⚠ Warning: In the event of a brake failure, bring the vehicle to a stop as soon as it is safe to do so. Do not continue to drive the vehicle. To do so could result in an accident or collision resulting in death or serious injury.

⚠ Warning: Greater care may be necessary after a long drive over salted or gritted roads or if driving in heavy rain, through water or a vehicle wash. Brake action may be delayed and increased braking pressure may be required.

⚠ Warning: Aston Martin recommend that the brake fluid is replaced before and after the vehicle is used for high performance driving such as a track day. Failure to do so may result in greatly reduced brake performance. Contact your Aston Martin Dealer.

⚠ Caution: If vacuum boost or a brake circuit fails, the footbrake will still operate, but with greater pedal pressure, increased pedal travel and longer stopping distances. Contact your Aston Martin Dealer.

📖 The high performance brake system used on this vehicle is designed to provide optimal braking under all operating conditions. However, an inherent characteristic of this braking system is some brake noise. Certain combinations of speed, braking forces and ambient conditions may also cause the brakes to squeal.

Brake Throttle Override

If the throttle and brake pedals are both pressed at the same time, the engine will restrict available torque. Normal functionality will return when the throttle pedal is pressed without the brake pedal or the brake pedal is released.

Carbon Ceramic Brakes

⚠ Warning: Track day use and high speed driving: For track use or high speed driving new brake pads must be subject to specific conditioning. Failure to correctly condition the pads may result in greatly reduced brake performance. Contact your Aston Martin Dealer.

Carbon ceramic brake systems combine low weight with high performance, offering:

- Reduced unsprung weight (mass of components not supported by the suspension) to improve vehicle handling.
- Improved rate of wear characteristics.
- Improved braking performance.

 *The rate of wear of the brake pads and rotors will depend on driving style and usage conditions. Track day usage will increase the rate of wear of rotors and pads.*

Brake Warnings

⚠ Warning: If either brake warning symbol comes on, you should immediately be prepared for increased stopping distances or partial failure of the braking system.

If the brake warning symbol  comes on while driving, the brake system has a fault and braking performance may be affected.

If the brake warning symbol  comes on while driving:

- The brake booster system has a fault and braking performance may be affected.
- The brake fluid level is insufficient.

 *A message will also show in the instrument cluster window with further information.*

Stop as soon as possible in a safe and convenient place. Apply the footbrake and make sure that the park brake is fully released. If the warning symbol stays ON, do not drive the vehicle. It is essential that the brake system is checked immediately. Contact the nearest Aston Martin Dealer.

ABS Warnings



⚠ Warning: If the ABS warning symbol comes on, you should be aware that wheels could lock during extreme braking or when braking on slippery surfaces.

ABS is monitored for correct operation while the ignition is on. If a fault is detected, the  will come on and the ABS will be either partly or fully off. Normal braking will continue to function without ABS.

In the event of an ABS fault, have the braking and ABS systems checked immediately by an Aston Martin Dealer.

ABS and Electronic Stability Program (ESP) Warnings

⚠ Warning: If the ABS and ESP warning symbols come ON, you should be aware that wheels could lock during extreme braking or when braking on slippery surfaces. Steering performance can also function differently and there is increased risk of skidding and/or accident.

If  and  and  come ON while driving both ABS and ESP have a fault. The brake system will continue to operate, but without assistance from either ABS or ESP. Both front and rear wheels may lock under heavy braking which can result in longer braking distances in an emergency stop.

 A message will also show in the right instrument cluster window with further information.

Drive on carefully and have the braking and ABS systems checked immediately by an Aston Martin Dealer.

Anti-Lock Braking System

The Anti-lock Braking System (ABS) helps prevent the road wheels from locking and causing the vehicle to skid during emergency braking. This also assists the driver in maintaining steering and directional stability.

If the braking force exceeds tire grip in an emergency braking situation, the ABS operates to prevent the wheels locking. A pulsating effect is felt through the brake pedal when this happens. This is a normal effect of the ABS operating.

Safety

It is always the driver's responsibility to drive safely with regard to driving conditions and according to the law. The fact that a vehicle is equipped with ABS must never let the driver be tempted into taking risks which could affect his or her safety or that of other road users.

The addition of ABS cannot overcome the consequences of trying to stop in too short a distance, cornering at too high a speed, or aquaplaning (where the tires are prevented from contacting the road surface by a layer of water).

The driver should always take road conditions into account. A slippery road surface always requires more braking distance for a given speed, even with ABS. Stopping distances can increase with ABS compared to locked wheels on slushy snow, gravel, sand or certain heavily corrugated or ridged warning sections of road surfaces.

If any braking system malfunctions, have the braking and ABS systems checked immediately by your Aston Martin Dealer.

Automatic Emergency Braking (AEB)

⚠ Warning: AEB is an aid only and does not replace the need for driver awareness. It is the driver's responsibility to be aware of their surroundings. Always make sure that there is a suitable braking distance for your vehicle.

 AEB is disabled when ESP is set to Sport+ or Off

AEB is used to reduce the risk of an accidental collision with a pedestrian, cyclists or another vehicle. This is achieved by showing the  symbol in the instrument cluster and audible warnings when a collision risk is detected. If the driver does not react to the risk of a collision, the system can also automatically apply the brakes.

AEB warnings and braking intervention will continue as long as the risk of collision is present. The system can be overridden by pressing the accelerator pedal or by turning the steering wheel.

 **Warning: If the driver does not react, and the vehicle is required to apply the brakes, this will happen for a maximum of 1.8 seconds. The purpose of the system is to gain the driver's attention to control the vehicle, and reduce the risk of rear impact from vehicles behind.**

 AEB is set to on for each ignition cycle at the previously set sensitivity level.

The sensitivity of warnings for AEB can be adjusted in the infotainment between *Early* and *Late* warnings or set to off (Refer to 'Automatic Emergency Braking', page 12.3).

If AEB is set to off,  will be shown in the instrument cluster.

System Limitations

AEB may not function correctly in the below conditions:

- The area around the multi purpose camera is dirty, damaged or otherwise covered.
- Glare into the multi purpose camera from the sun or other road users' headlamps.
- A pedestrian's outline is concealed, or the system cannot determine a pedestrians outline due the background.
- The vehicle in front is either too narrow, such as a motorbike or the vehicle in front is offset and not following the same driving line.
- Vehicles rapidly moving into radar range or complex traffic.
- There is lots of background radar reflection such as a multi-storey car parks.
- The background environment changes frequently or rapidly.
- The driver is clearly engaged in the driving task by having a high activity on the accelerator pedal or steering wheel.

In addition, the braking performance of AEB is strictly related to vehicle conditions (such as worn tires, and brake pads), road conditions (such as wet or other road surfaces with low grip) and weather conditions (such as snow and heavy rain).

Fault Conditions

In the unlikely event that there is a fault that prevents safe operation of AEB, the system will be automatically deactivated, and a warning message will be shown in the instrument cluster along with the  symbol. Contact your Aston Martin Dealer.

Brake Pad Conditioning

⚠ Warning: For track use or high speed driving, new brake pads must be correctly conditioned. Failure to correctly condition the pads may result in greatly reduced brake performance. Contact your Aston Martin Dealer for further information.

When new brake pads are installed the brake rotors and pads need to be conditioned. During this time, brake performance will be reduced.

Avoid excessive braking, such as hard stops from high speed and steep descents, for the first 300 km (200 miles)¹ after new brake pads are installed. For further information contact your Aston Martin Dealer.

¹. Distances can vary depending on driving conditions and frequency of brake use

Park Brake

⚠ Warning: *If the brake system warning symbol is on or flashing, do not rely on the park brake to hold the vehicle stationary. Contact your Aston Martin Dealer.*

⚠ Caution: *Secure parking of the vehicle is dependent on being on a hard and stable surface. The rear wheels must be on a suitable surface to prevent vehicle movement.*



 *The park brake operates on the rear wheels of the vehicle.*

 *The park brake is automatically applied when P (Park) is selected.*

Drive Away Release

⚠ Warning: *Do not exit the vehicle with the engine operating and the transmission in D (Drive) or R (Reverse). Always select P (Park) before exiting the vehicle. If the transmission is left in D (Drive) or R (Reverse), the vehicle can overcome the park brake and start to move.*

 *The engine must be started, the driver's side door must be closed and the driver's seat belt must be buckled for Drive Away Release to operate.*



With the park brake applied, select D (Drive) or R (Reverse) and press the throttle pedal. The park brake will release as the vehicle moves forwards or backwards, and the ₁ ₂ symbol will go off to show the park brake has been released.

The park brake will not release when moving from stationary if a vehicle door is open. In this case the park brake must be released with the park brake switch.

1. Canada

2. USA



Manual Park Brake Application

When the vehicle is stationary, push the park brake switch (A) in and release. The ¹ ² warning symbol in the instrument cluster will come on when the park brake is applied. The stop lamps will not come on.





Manual Park Brake Release

 *The ignition control must be on to release the park brake.*

First apply pressure to the foot brake then pull on the park brake switch and release. The ³ ⁴ symbol will go off to show the park brake has been released.

Emergency Operation

 **Warning: Repeated use of the park brake to slow the vehicle, or driving the vehicle with the park brake applied can cause serious damage to the brake system.**

In an emergency, push and hold the park brake switch to reduce speed. The ⁵ ⁶ symbol will come on, a warning sound will be heard and a warning message will be shown in the instrument cluster.

Release the switch to cancel the park brake application. The park brake will only apply as normal once the vehicle has stopped movement.

1. Canada
2. USA
3. Canada
4. USA

5. Canada
6. USA

Electronic Stability Program (ESP)

Cold Weather Operation

At low temperatures such as below 0°C (32°F) moisture within the brake pads may freeze and cause the brake pads to bind to the brake rotors when the park brake is applied. Additional torque may need to be applied when the vehicle is first used after extended periods of being parked, and there may be a noise as the brake pads become free. Once released, the brakes will operate as normal.

If the vehicle is parked in wet and cold conditions for an extended period of time, the vehicle should be parked on a stable, flat surface where possible. If it is safe to do so, the park brake should be manually released.

Park Brake Faults

Low Battery Voltage

If the battery voltage is too low, the park brake cannot be put on or off. Connect an auxiliary battery if the battery voltage is too low.

System Faults

If a fault in the system is detected, a warning message will be shown in the instrument cluster. Contact your nearest Aston Martin Dealer.

⚠ Warning: It is the driver's responsibility to drive safely according to the law and with due regard to prevailing conditions.

⚠ Warning: ESP must never let the driver be tempted into taking risks which could affect his or her safety or that of other road users. ESP cannot overcome consequences of applying too much engine power for prevailing conditions.

The Electronic Stability Program (ESP) is designed to improve driving safety when the tires are at the limits of their grip capabilities. This is done by control of engine torque and application of the brakes at individual wheels.

⚠ Caution: If repair or replacement of the steering or other surrounding equipment is necessary, always refer to your Aston Martin Dealer. There is a sensor in the steering system which detects steering angle. If the centre position of the steering deviates, the ESP may not operate correctly.

⚠ Caution: ESP may not operate correctly when using tire chains.

⚠ Caution: Use tires of the same manufacturer, brand, type, tread pattern and correct size specified in this handbook (Refer to 'Wheels and Tyres', page 13.16) for this vehicle on all four road wheels. Do not mix new and worn tires on the same axle.

ESP Modes

ESP has four modes of operation:

Wet

Wet mode delivers the highest level of stability and traction control on low friction road surfaces experienced in wet driving conditions as well as snow and icy conditions. This mode is calibrated to provide predictable torque control and avoid harsh brake interventions to

maximize stability.  will flash in the instrument cluster when in operation.

ESP On

ESP On is the default setting each time the engine is started.  will flash in the instrument cluster when in operation. Engine torque and application of the brakes at individual wheels will be controlled by ESP to aid stability. ESP On is suitable for most driving conditions, however for increased stability Wet mode is recommended.



ESP Track

 **Warning: ESP TRACK is intended for use on a dry track. Greater driver input will be required to maintain vehicle stability.**

Track mode raises the thresholds at which the ESP operates and allows greater wheel slip from traction control and reduced yaw stabilisation. When *ESP Track* is selected,  will be shown in the instrument cluster.

ESP Off

In ESP off, traction control is set to be user adjustable.

 will show in the instrument cluster along with the set level of slip from traction control .

For more information, (Refer to 'Traction Control', page 5.39).

To Change ESP Mode



To change the ESP modes the engine ignition must be on with the transmission in gear.

Press  (A) for to change from *ESP On* to *ESP Track*.

To set the ESP mode to *Off*, press and hold .

Press and hold  with *ESP Off* to set back to *ESP On*.



 If drive mode is set to *Wet*, ESP mode will automatically change to *Wet*. Press  again to set ESP *On*.

Traction Control

Traction control is a function of ESP and is used to prevent excessive wheel spin at standing starts, or during acceleration. Wheel spin is usually caused by excessive use of the accelerator pedal, or slippery, loose or bumpy road surfaces.

 **Warning:** It is always the drivers responsibility to drive safely according to the law and with due regard to prevailing conditions.

 **Warning:** Traction control cannot overcome the consequences of applying too much engine power for conditions, and must never let the driver be tempted into taking risks which could affect their safety or that of other road users.

To prevent wheel spin and maintain vehicle stability in such situations, traction control will:

- Brake either of the driven wheels when they start to slip.
- Adapt the engine torque to a level corresponding to the traction available on the road surface.

 These symptoms are normal and will clear as wheel spin is eliminated and normal engine power is restored.

If traction control operates when driving on extended icy or slippery surfaces, reduce engine power as necessary until  goes off.

Adjustable Traction Control

When ESP is set to Off, traction control set to be user adjustable. Use the drive mode select dial to adjust the level of slip allowed by the traction control between 1 (least slip) to 9 (traction control off).



The set level will be shown and a set level reminder notification  will be given in bottom of the instrument cluster.

Engine torque reductions are used to maintain a controlled slip condition. When TC is set to level 1, engine torque reduction will be at it's strongest to keep the slip level low. The level of engine torque reduction decrease as the TC level increases up to level 9. At level TC 9 (TC Off) there is no engine torque reduction.

Anti-lock Braking System (ABS)

The Anti-lock Braking System (ABS) will change its operation depending on conditions.

When ESP is set to On or Wet, the ABS is tuned to give a level of vehicle performance, control and stability under braking that will cover everyday driving situations and weather (dry, wet, ice and snow).

When ESP is set to Track or Off, the ABS is tuned to allow more experienced drivers to drive closer to the limits of the vehicle's ability and enjoy its natural balance in a track environment. Braking performance is given greater priority over stability.

The ABS will adapt when the tires are at a higher working temperature, such as when the vehicle is driven on a track. The driver will have more control over brake performance before the ABS is activated.

Electronic Differential (E-Diff)

This vehicle features an Electronic Rear Differential (E-Diff), which works with the ESP system to adjust and control how the engine's power is delivered to the rear wheels. Electronic management controls how the rear differential lock operates, using sensors around the vehicle to detect how the car is behaving. The system is then calibrated for how it should react in relation to the vehicle movement and is able to adjust for driver inputs. At any given road speed it can detect very subtle changes in dynamic behaviour which may indicate understeer or oversteer. The system can then increase or decrease locking torque across the rear axle to maximize performance whilst keeping the vehicle stable and under control.

Tire Pressure Monitoring System (TPMS)

As an added safety feature, your vehicle has been equipped with a tire pressure monitoring system (TPMS) that illuminates a low tire pressure telltale  when one or more of your tires is significantly under-inflated. Accordingly, when the low tire pressure telltale illuminates, you should stop and check your tires as soon as possible, and inflate them to the proper pressure. Driving on a significantly under-inflated tire causes the tire to overheat and can lead to tire failure. Under-inflation also reduces fuel efficiency and tire tread life, and may affect the vehicle's handling and stopping ability. Please note that the TPMS is not a substitute for proper tire maintenance, and it is the driver's responsibility to maintain correct tire pressure, even if under-inflation has not reached the level to trigger illumination of the TPMS low tire pressure telltale.

Each tire, including the spare (if provided), should be checked monthly when cold and inflated to the inflation pressure recommended by the vehicle manufacturer on the vehicle placard or tire inflation pressure label.

(If your vehicle has tires of a different size than the size indicated on the vehicle placard or tire inflation pressure label, you should determine the proper tire inflation pressure for those tires.)

Tire Pressure Display

The TPMS display can be shown in the instrument cluster display in the **Vehicle** menu. The screen itself shows the pressure in each tire as well as a temperature display. If a tire is below the minimum pressure this will be shown in red as well as the  symbol being illuminated at the bottom of the screen.

 *Tire pressures will be displayed after the vehicle has been driven for a few minutes.*

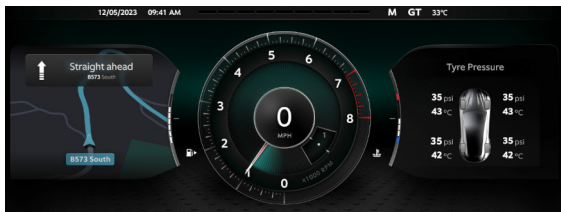

 **Warning:** *When a tire pressure warning is detected, reduce the vehicle speed to a safe level. Stop in a safe and convenient place and inspect the tire(s).*

 *The tire pressures may be displayed in the wrong positions for a short time if the wheels have been moved on the vehicle. After a few minutes of driving, the TPMS will calibrate and the tire pressures are displayed in the correct positions.*

TPMS Reset

 *All warning messages are erased and warning lamps go out when the TPMS is reset. The TPMS will use the new tire pressure values as reference values.*

To reset the TPMS tire pressure values, press and hold the **OK** button on the steering wheel. Press **OK** to confirm the new pressures.

TPMS Malfunction Warning

The TPMS malfunction indicator is combined with the low tire pressure telltale. When the system detects a malfunction, the telltale will flash for approximately one minute and then remain continuously illuminated. This sequence will continue upon subsequent vehicle start-ups as long as the malfunction exists.

When the malfunction indicator is illuminated, the system may not be able to detect or signal low tire pressure as intended. TPMS malfunctions may occur for a variety of reasons, including the installation of replacement or alternate tires or wheels on the vehicle that prevent the TPMS from functioning properly. Always check the TPMS malfunction telltale after replacing one or more tires or wheels on your vehicle to ensure that the replacement or alternate tires and wheels allow the TPMS to continue to function properly.

 A malfunction of the tire pressure monitor can take up to ten minutes to be shown. The TPMS warning lamp will go out when the fault has been resolved and after several minutes of driving.

Eco Driving Features

Stop/Start

The Stop/Start function switches the engine off when the vehicle comes to a stop to reduce fuel consumption and emissions.

Setting On or Off





Stop/Start is controlled by the  button (A) on the lower console. When the system is off,  will be shown in the instrument cluster.

Engine Stop Conditions

With Stop/Start active, the engine will switch off when the vehicle is completely stopped, the transmission is in either D (Drive) or N (Neutral) and if the following conditions are met:

- The transmission is in either D (Drive) or N (Neutral).
- The vehicle battery condition is suitable.
- The hood is closed.
- The driver's door is closed.
- The driver's seatbelt is fastened.
- The engine is at operating temperature.
- The outside temperature is within a suitable range.
- The vehicle climate temperature has reached the set temperature.
- The engine has been on for a minimum of 20 seconds.

If any of the above conditions are not met when the engine attempts a stop/start event, the  symbol will be shown, otherwise  will be shown when the system is active.

When the engine is switched off, all the remaining vehicle systems will continue to operate (navigation, media etc).

Engine Start Conditions

The engine will automatically start again when:

- The engine has been switched off for 3 minutes.
- The engine goes above or below operating temperature.
- The throttle pedal is pressed.
- The brake pedal is released.
- The steering wheel is turned.
- If  has been pressed on the centre stack.
- R (Reverse) is selected.
- *Sport+* is selected for drive mode.
- The driver's seatbelt is unfastened.
- The driver's door is opened.
- The vehicle begins to roll.
- The battery condition would prevent restart.
- The vehicle interior has dropped below or increased above the temperature set by the climate control system.

Emergency Stops

If the vehicle detects a level of braking that it determines to be an emergency stop, the stop/start will prevent the engine switching off.

Park Assist Systems

⚠ Warning: *The park assist systems are for aid only. It is the driver's responsibility to be aware of their surroundings when parking or reversing.*

Park Distance Control

⚠ Caution: *It is always the driver's responsibility to detect obstacles and estimate the vehicle's distance from them. Some overhanging objects, barriers, thin obstructions or painted surfaces which could possibly cause damage to the vehicle may not be detected by the system. Always be aware of your surroundings when using the park assist systems.*

⚠ Caution: *Do not clean the sensors with abrasive or sharp objects. This can damage the sensors.*

 *For reliable operation, the sensors in the front and rear bumpers should be kept free from ice, frost and grime. If a high pressure spray is used to clean the vehicle, the sensors should only be sprayed briefly and not from a distance of less than 200 mm (8 inches).*

The Park Distance Control (PDC) system will give a series of warning tones if objects are detected within range of the vehicle.

Activation

PDC will activate automatically at ignition on and when D (Drive), R (Reverse) or N (Neutral) is selected. The sensors activated depend on which gear is selected.

Gear Selected	Sensors Activated
(D) Drive	Front sensors only.
(R) Reverse, (N) Neutral	Front and rear sensors.
(P) Park	Sensors off.

Deactivation

PDC will deactivate when the vehicle speed exceeds 11 mph (18 km/h). The system is reactivated automatically when the vehicle speed is lower.

To manually deactivate PDC press . The indicator LED will be set to off to show the system is deactivated.

Operation

⚠ Caution: *In heavy rain or similar adverse conditions, the PDC sensors may not always be able to accurately measure distance to close objects. A fully laden vehicle or irregular obstacles may also cause inaccurate measurements. Take extra care in these circumstances.*

If an obstacle is detected to the front or rear of the vehicle, a series of warning tones will be heard from the front or rear speaker respectively. The frequency of the warning tones increase as the vehicle approaches the obstacle.

The beep becomes a continuous tone when an obstacle is detected at or within approximately 0.3 m (1 ft) from the front or 1 m (3.3 ft) from the rear of the vehicle.

 *If an ultrasonic frequency using the same frequency band as the sensors is detected, the PDC system can give spurious warning tones.*

 *The PDC system uses inner and outer sensors. When manoeuvring forward into a garage, the front outer sensors will cease detection if they detect a stationary or receding object for three seconds or more. This allows detection directly in front or behind the vehicle in this type of manoeuvre.*

The LED will flash if a fault is detected in the system and a single three second tone will be heard (only once per ignition cycle). The system is automatically disabled when a fault is detected.



360° Camera System

⚠ Caution: The camera system can show a distorted, delayed or incorrect view of obstacles or not at all. Obstacles will not be shown under, or in very close proximity to, the front or rear bumpers. Care should also be taken in the blind spots close to the door mirrors, tailgate or transitional areas between cameras in the top-down view.

⚠ Caution: Objects that are not at ground level can appear further away than they are. Care should be taken when manoeuvring around items such as tow bars and vehicle bumpers.

The 360° camera system uses four cameras (front, rear and both door mirrors) to give a complete view of the vehicle's immediate surroundings. The system can then be used in a split screen view to suit different driving scenarios.

Activation

To activate the 360° camera, press the  button on the lower console. The camera will show the split screen with either the front or rear view, depending on the transmission selection.

 *The camera system will be disabled when the vehicle speed exceeds 16 km/h (10 mph). At higher speeds the camera display will still be selected, but no image will be shown.*

The system will display images again when the vehicle speed drops below 11 km/h (7 mph).

 *The ignition must be on for the cameras to operate.*

Activation by Reverse

The rear view can be set to activate automatically when reverse is selected (Refer to 'Parking', page 12.5).

View Selection

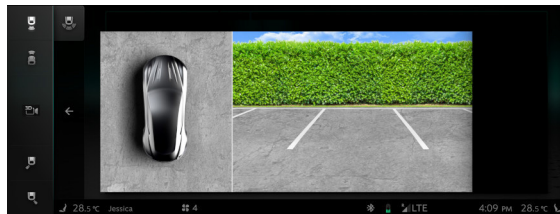

Select a view from view selection bar. The split-screen views that can be shown are:

- Rear view (select from narrow and wide view).
- Front view (select from narrow and wide view).
- 3D view.
- Left corner 3D view.
- Right corner 3D view.

Park Distance Control with Top View (Front and Rear views)

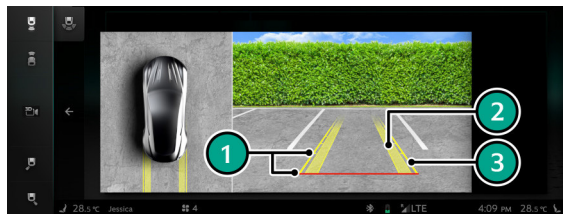

To aid with parking the vehicle, a dynamic overlay screen will be shown over the camera image. The overlay screen adjusts with steering angle and shows the following information:

1. Distance markers
 - **Red Line:** 0.35 m (1.1 ft) behind the vehicle.
 - **Yellow Markers:** 1 m (3.3 ft) behind the vehicle and the 0.5 m (1.6 ft) intervals.
2. Projected tire path.
3. Maximum vehicle width guideline (includes door mirrors).

Rear Cross Traffic Alert

⚠ Warning: Rear Cross Traffic Assist is an aid only. The system cannot detect pedestrians walking behind the vehicle. It always is the driver's responsibility to be aware of their surroundings when parking or reversing.

The Rear Cross Traffic Assist (RCTA) uses the blind spot assist radar modules to alert the driver when a moving vehicle or bicycle approaches behind your vehicle¹.

When reverse gear is selected the RCTA system searches for moving objects behind the vehicle. If an object or vehicle is detected, an audible warning is given and a warning is shown on the infotainment screen in the direction of the detected vehicle.

If the driver does not intervene and there is still the risk of a collision, then the vehicle will automatically apply the brakes.

RCTA can be set to on or off in the vehicle setting menu (Refer to 'Rear Cross Traffic Assist', page 12.4).

¹ RCTA only operates for moving vehicles. Static obstructions will not be detected but will activate the parking sensors instead.



Climate Control

Climate Controls.....	6.2
Defrost and Demist	6.6
Climate Control Operating Tips.....	6.7

Climate Controls

Centre Stack Climate Controls



[1] DEMIST:

Press for maximum defrost or demist on or off. Outside air intake is automatically selected and air conditioning is automatically started.

[2] HEATED REAR WINDOW:

Press to set the rear window and door mirror heaters on or off. The rear screen heater will automatically set to off after 20 minutes and the door mirror heaters set to off after 6 minutes.



[3] AUTO:

Press for automatic climate control (Refer to 'Automatic Climate Control', page 6.5).

[4] A/C:

When in manual mode press and release to set the air conditioning on or off.

[5] AIR CIRCULATION:

⚠ Warning: Re-circulated air can cause the interior glass to mist up in cold or rainy weather. If demisting is required, use the air conditioning.



Controls the source of air entering the vehicle. Press to select re-circulated air (button LED on). Press and hold for more than two seconds to close the windows.

Press again to select outside air as source (button LED off). Press and hold for more than two seconds and the windows will open to their last position¹.

Use the re-circulated air position when going through tunnels, driving in congested traffic (high engine exhaust areas) or when maximum cooling is required.

Outside air is used as the default air source and should be used for normal conditions and demisting.

¹ If windows were open before selecting re-circulated air

[6] SYNC:

Press to synchronize the left and right climate zones.

**[7] TEMPERATURE:**

Use to increase or decrease the temperature.

[8] FAN SPEED:

Use to increase or decrease the fan speed.

[9] SEAT HEATING/COOLING:

⚠ Warning: Do not press the seat heater switch repeatedly. This can cause the seat to become very hot and can cause burn injuries to persons with limited sensitivity to temperature changes.

- **Seat Heating** (standard):

Press to cycle the seat heating level on the driver or passenger seats. The LEDs show which heating level is set, where the higher the number of LEDs illuminated, the greater the heating level.



- **Seat Cooling** (optional):

Press to cycle the seat cooling level on the driver or passenger seats. The LEDs show which cooling level is set, where the higher the number of LEDs illuminated, the greater the cooling level.

**Vent Adjustment**

To adjust the air vents, use the vent knob (A). Push up or down to adjust the blades inside the vent. Push left or right to adjust the angle of the vent unit. Rotate the knob to open or close the vent.

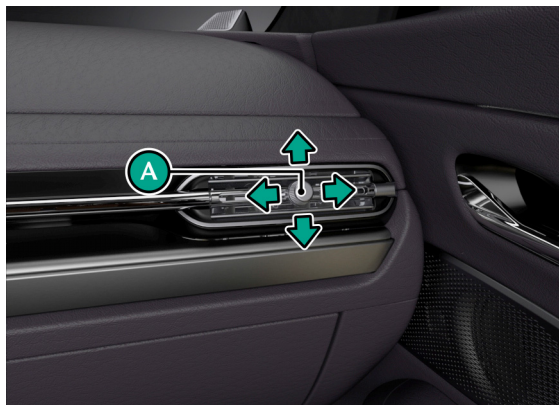

Infotainment Climate Controls

Climate

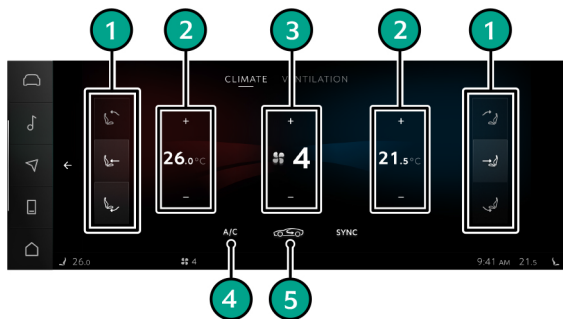

[1] AIR DISTRIBUTION:

Swipe through the air distribution list and tap to select an airflow direction.

[2] TEMPERATURE:

Tap the + and - buttons to adjust the temperature.

[3] FAN SPEED:

Tap the + and - buttons to adjust the speed list.

[4] A/C:

Tap to set the air conditioning to on or off.

[5] AIR CIRCULATION:

⚠ Warning: Re-circulated air can cause the interior glass to mist up in cold or rainy weather. If demisting is required, use the air conditioning.

Controls the source of air entering the vehicle. Tap to set the air supply to re-circulated or outside air.

Use the re-circulated air position when going through tunnels, driving in congested traffic (high engine exhaust areas) or when maximum cooling is required.

Outside air is used as the default air source and should be used for normal conditions and demisting.

Ventilation

Select one of three ventilation modes:



- Diffuse
Low level of airflow at a warmer temperature setting.
- Medium
Standard airflow with medium airflow.
- Focus
High level of airflow at a cooler temperature setting.

Automatic Climate Control

The temperature is maintained at a set level in automatic mode. The climate system will automatically control the temperature, airflow and the air distribution according to the interior and exterior conditions.

To set a temperature for automatic operation:

- Set a temperature.
- Press .
- The LED indicator lamp will switch on.

 Press and hold  to set the climate control to a default setting of 22°C (71°F), low fan speed and vents open.

 Maximum fan speed will not be available until the engine has reached its normal operating temperature.

 Any changes to the air distribution or airflow speed will cancel automatic climate control.

Manual Climate Control

Manually set the temperature, airflow speed and air distribution:

 **Warning: Re-circulated air can cause the interior glass to mist up in cold or rainy weather. If demisting is required, use the air conditioning.**

 *To prevent cold air blowing from the vents, airflow speed is reduced until the engine warms up.*

 *The climate system will produce the selected temperature regardless of in-vehicle conditions.*

For an increased cooling effect, press  to use re-circulated air.



Defrost and Demist

 **Caution: To defrost or demist the windscreen on vehicle start up in extreme cold weather conditions, operate the engine at 1500 rpm. Always make sure that the transmission is in P (park) and the park brake is applied.**

Press . The outside air intake is automatically selected, the temperature is set to maximum and air conditioning is started.

 *If the engine is cold the air conditioner will not start up until the engine has started to warm up.*

To cancel automatic defrost or demist either:

- Press  again.
- Press .
- Select a different airflow mode.

 *The automatic defrost setting times out after 6 minutes.*

Climate Control Operating Tips

- Moisture which forms on the evaporator in the air conditioning unit is discharged via a drain tube onto the road. After stopping, small puddles of water may form underneath the vehicle. This is normal and does not show a system malfunction.
 - Set the climate system to off when in a car wash or if the vehicle is being pressure washed.
 - Air conditioning may not function when the outside temperature approaches -6°C (21°F) (indicator stays on even when system is off).
 - Windows can fog up easily in humid weather. Use the climate control system to demist the windows.
 - Clear all obstructions like leaves, snow and ice from the hood and the air inlet below the windscreen to improve the system efficiency.
-
- Use the 'outside air' position in normal conditions. The 're-circulated air' position should be used temporarily when driving on dusty roads or for quick cooling or heating of the interior.
 - If the vehicle has been parked in direct sunlight during hot weather, open the windows to let warm air escape, then close the windows and operate the climate control system.
 - Operate the climate control system at least once a month to keep internal parts lubricated.
 - Have the climate control system checked before the weather gets hot. If the climate control system is low on refrigerant or has a malfunction, consult your Aston Martin Dealer.
 - Mist may come out from the vents when using the air conditioning. This is humid air being suddenly cooled and not a sign of a malfunction.



Phone System

Bluetooth Device Management	7.2
Calls.....	7.4
Phone Settings.....	7.7
Wireless Phone Charger.....	7.8

Bluetooth Device Management

Bluetooth[®]₁ technology is a standard for short-range wireless data transmissions up to approximately 10 metres. Bluetooth can be used to connect your mobile device to the vehicle infotainment system. This system can then be used to operate the hands-free phone system, Bluetooth audio streaming and internet access.

Pairing a Device

 Bluetooth[®] must be activate on both the vehicle and the mobile device to be used. To check the Bluetooth[®] system is active on the vehicle (Refer to 'System Settings', page 12.6).

 The mobile device must be set to discoverable mode. Refer to the mobile device manufacturers instructions.

Before a device can be used, it must be paired to the infotainment system.

To add a new device, tap . The vehicle will automatically search for available devices to connect to. Available devices will be shown as a list with the option to connect to individual devices. The *Device Manager* button will also be available to manage individual devices. If no devices are available, a message will be shown to check that Bluetooth is active on both the vehicle and the mobile device.

To connect a device, select it from the list and tap connect. If the device has previously been paired, this will now connect. If the device is a new device, a passcode will be shown on the infotainment screen and the device. Confirm from the device to pair with the infotainment system.

¹ The Bluetooth[®] word mark and logos are registered trademarks owned by Bluetooth SIG, Inc., and any use of such marks by Aston Martin is under license. Other trademarks and trade names are those of their respective owners.

Selecting a Device Function

Once a mobile device is paired, it can be set as an audio device, phone connection, or for smart phone connections. If a device is set as a phone connection, the infotainment system will request access to call history, contact list and messages.

One device can be set to function both as a telephone device and an audio device, or separate devices can be used for each function.





When more than one device has been paired, you can choose which device to use for a primary and secondary phone connection. To choose a device, scroll through the list and select the device to be used and select the function you wish to activate on the device.

 *Only one device can be used in each connection at any one time. The active device function will be highlighted in blue on each device.*

 *You cannot change the active device during a call.*

Bluetooth Status

The status bar will be shown for each connected device that is audio and phone enabled.

- If the Bluetooth symbol is grey , this shows that a Bluetooth device is out of Bluetooth range.
- If the Bluetooth symbol is white  a Bluetooth device is selected.
 - Tap  to enable or disable the device to be used for phone functions.
 - Tap  to enable or disable the device to be used for media functions.

To Delete a Device

To delete a device, select a device from the device list that is not actively connected and press . A message will show to confirm the device has been removed.

 *It is recommended that the vehicle connection is also removed from the Bluetooth® connected devices on your mobile device.*

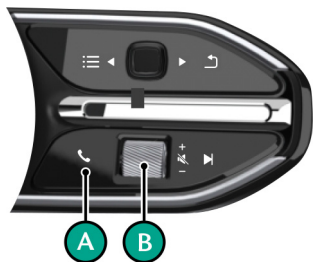

Calls

Call Controls



Select a Contact to Call

A contact number can be selected by:

- Choose a contact from the **Recent**, **Favourites** or **Contacts** lists.
- Enter a number with .
- Search for a contact with the  function either with the on-screen keyboard ¹ or voice control.

Select on a contact and tap  or press the call button (A) on the steering wheel.

Incoming Calls

Whenever a call is received, a pop-up window will be shown with the callers name.

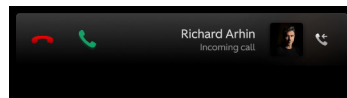



To Answer a Call

Press  (A) on the steering wheel, or tap .

Mute Function

To mute an incoming call, press the scroll wheel  button (B).

To Reject a Call

To reject the incoming call tap . If the call ring tone is already muted, press  again to reject the call.

¹. Only available when the vehicle is stationary.

Active Call

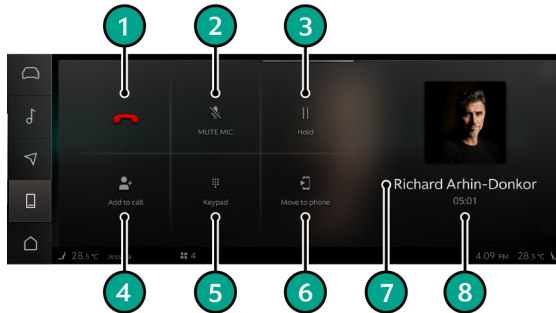

During a call you will be shown the below options:

[1] End Call: Tap to end the call.

[2] Mute Mic: Select to turn the microphone to on or off.

[3] Hold: Tap to put the caller on hold or tap again to take off hold.

[4] Add to Call: Tap to add a second call.

[5] Keypad: Opens a keypad menu to use with automated telephone menus.

[6] Move to: Select to divert the active call to the mobile device instead of the vehicle telephone system.

[7] Contact Name: Shows the name of the contact in the call.

[8] Call Duration: Shows how long the call has been connected for.

Multiple Calls

Second Incoming Call

If a second call is answered during an active call, the system will respond depending on how many connected phones there are.

- If only one device is connected and activated for use as a phone, then the initial active call will be put on hold.
- If a device is connected and activated for use as a phone, and is used to answer the second call, then the initial active call will be ended.

If the call is rejected, the system may respond in one of 3 ways¹:

- The incoming call is rejected, and the original call is continued.
- The incoming call is accepted, and the original call is ended.
- Both calls will be ended.

Two Active Calls



If there are multiple calls active, both will be shown on the right side of the call screen. The top call (1) is the active and the bottom call (2) will be held. To switch which call is active, tap the contact name. Selecting a new active call will put the other call on hold.

To combine the two calls to create a conference call, tap the Merge Calls button (3).

 *The held call can be activated automatically when the active call is ended, depending on network supplier or mobile phone.*

¹ Operation will vary by mobile manufacturer or network supplier.

Phone Settings

Conference Calls

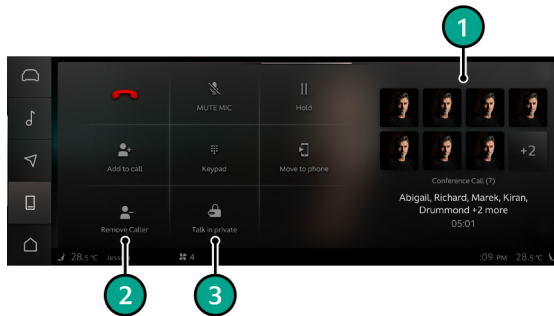

The number of participants (1) is shown on the right side of the call screen.

To manually remove a caller from the call, tap Remove Caller (2), and select a contact.

To talk in private to a participant, tap Talk in Private (3) and select a contact. The display will then show the conference call and the private call as two active calls.

 Some features may not be supported by all phones or their operating systems.

- **Incoming Ring Tone Volume:**
Adjust the volume for the incoming call ring tone.
- **Default In-Call Volume:**
Adjust the volume for voices in the call.
- **Mute Audible Alerts During Calls:**
Prevents audible instructions and warnings from systems such as navigation whilst a call is active.
- **Contacts list:**
Set the display format of contact names as First Name, Last Name or Last name, First name.

Wireless Phone Charger

⚠ Caution: Do not place keys or other metal objects onto the charge pad. Metallic components can interfere with the wireless charge pad.

⚠ Caution: Do not place items that may be affected by electromagnetic waves, such as credit cards and parking passes on the wireless charge pad. These type of items may become damaged and not work correctly.

A wireless charger pad is available below the centre console to charge compliant mobile devices whenever the infotainment screen is on.



Place the mobile device in the centre of the charger pad with the display facing upwards.

If the mobile device was already charging through a USB cable, the wireless pad will take over charging but will not interrupt the data connection.

Connected Car

Connected Car Set Up	8.2
Convenience Features	8.3
Vehicle Management Features.....	8.5
Vehicle Services Functions	8.7

Connected Car Set Up

Aston Martin App

The Aston Martin App lets users interact with their vehicle from the palm of their hand and perform a variety of functions such as:

- Remote check for your Aston Martin, such as fuel levels, windows, doors, fluid levels and more.
- Clear notifications and vehicle health alerts, so you always know what's happening with your vehicle.
- Constant reassurance. Know that your vehicle is secure with Aston Martin's last known location.
- Activate indicators and horn remotely, so you can always find where your vehicle is parked.
- Safety first. Limit power, torque, and performance settings when needed.
- Always-on protection. Get notified if your vehicle or battery is being tampered with.

 *The continued use of GPS or having GPS running in the background can dramatically decrease the battery life of your mobile phone.*

 *As part of continuous improvement, further functionality and usability options will be introduced.*

Aston Martin ID

When you purchase your vehicle, you will be invited to create an Aston Martin ID. This will grant access to the full suite of connected features, and allow Customers to set up various personalisation features.

When you have your Aston Martin ID, you will be able to remotely communicate, control and send data to your vehicle.

 *If you do not have an Aston Martin ID, please contact your Aston Martin Dealer.*

App Download

Get the Aston Martin App on IOS. Download from the App Store[®]₁



Get the Aston Martin App for Android[™]₂. Download on Google Play.



¹. App Store is a trademark of Apple Inc., registered in the U.S. and other countries and regions.

². Android is a trademark of Google LLC.

Feature Availability

 Feature availability is correct at time of print but may be subject to change.

	Brazil	Canada	Chile	Mexico	Peru	USA
Convenience						
Real time Traffic	S	S	S	S	S	S
Online POI	S	S	S	S	S	S
OTA Map Updates	S	S	S	S	S	S
Theft Alert	S	S	S	S	S	S
Vehicle Management						
Locate	S	S	S	S	S	S
Identify	S	S	S	S	S	S
Protect	S	S	S	S	S	S
Vehicle Status	S	S	S	S	S	S
Vehicle Services						
ECall	-	-	-	-	-	-
Privacy Mode	S	S	S	S	S	S
OTA Updates	S	S	S	S	S	S

Convenience Features

Connected Navigation

The navigation system features integrated online connectivity to enable smarter navigation in real time, with the ability to dynamically interact both with the world around your vehicle as well as your lifestyle.

On-Board System

The integrated navigation system offers smarter mapping by using the latest maps, real time traffic data, dynamic Point of Interest (POI) searches and AI voice assistant requests.

Real Time Data

The system will always check the latest real time traffic data for a planned route. During the journey, data will be constantly checked and dynamic journey planning will be updated to provide the quickest time to destination.

Online POI Search

Connected navigation is able to search the internet to discover appropriate POI's and their associated information. For example, you can search restaurants, see their opening times, location and reviews as well as choose the POI as a destination.

OTA Map Updates

The system will automatically check for the latest map data available for its current region up to four times a year. If an update is available, this will download in the background and installed automatically. In addition, rapidly changing map data, such as road closures, satellite views or regions outside of the main mapping market, then local maps will be downloaded to provide seamless mapping.

Mobile App

The Aston Martin mobile app also features navigation support, such as POI lookup and mapping definition. These features allow you to plan routes and locations before a journey, with seamless communication to your vehicle for a truly effortless and efficient journey at all times. As part of continuous improvement, further functionality and usability options will be introduced.

Theft Alert

 *Theft Alert is not a replacement for a stolen vehicle tracking system and is managed through a support call centre.*

In the unlikely event of vehicle theft, attempted break in or suspected tampering, the Theft Alert function will notify the vehicle owner or assigned app user that the alarm has been activated.

If the alarm system is activated whilst the vehicle is locked and the alarm is armed, a notification alert will be issued in the app. If configured, this notification can also appear in your personal mobile device's notifications as well.

The location or lock status feature status will be available in the app menus, but is only a notification function if the vehicle alarm is triggered.

Vehicle Management Features

Locate

 *Locate functions rely on GPS information and so accuracy may be affected if your vehicle is parked underground, parking structures or dense urban environments. In such situations, only the last known GPS position may be given.*

The Locate function is used to help find your vehicle when left in areas such as particularly large car parks or parking in an unfamiliar area. Tap Locate in the Aston Martin mobile app to be shown the last location of your vehicle, and if necessary guided to your vehicle.

Identify

The Identify function is used to help in crowded and dark places by flashing the indicators and a short sounding of the horn to provide a visual and audible alert as to your vehicle's location.

Protect

The Protect function activates safe limits to certain systems of your vehicle, to give peace of mind should you wish to allow other drivers who are unfamiliar with your vehicle to use it within safe limits.

Once activated, the below features are limited:

- Vehicle speed will be limited to 140 km/h (87 mph).
- ESP will be set to wet mode to give safe acceleration and stability intervention.
- Drive mode selection is disabled.
- Manual gear selection will be disabled.
- Buttons to change drive mode and ESP are disabled.
- Engine power and torque will be limited.
- Telemetry functions in the infotainment will be disabled.
- All safety systems will be set to on as default.¹

¹ Driver will still be able to set Lane Keep Assist to off.

Activation

Protect can only be activated by the Primary app user and for security purposes cannot be delegated to other app users.

For safety, Protect can only be activated when the vehicle is stationary. If Protect is selected whilst the vehicle is moving, a notification is given in the app and Protect will be activated next time the vehicle is stationary.

Once active, switching the ignition, or activating privacy mode will not cancel Protect and will remain active until disabled by the Primary app user.

In-Vehicle Notification

A notification is given in the vehicle infotainment to alert the driver that the vehicle has Protect active. If the driver tries to change any of the limited parameters a pop up will be shown to explain that the feature is limited during Protect.

Vehicle Status

The Vehicle Status function provides real time statuses for various systems on your vehicle. This enables you to view vehicle health at any given time or be alerted to any matters that might require attention before the vehicle is driven.

Remote Vehicle Status

Within the app, you will be able to see the last status of the following systems:

- Live status
 - Doors open or closed
 - Windows open or closed
 - Convertible roof open or closed
 - Parking lamps on or off
- Live status and at last ignition off
 - Vehicle fluid levels (fuel, screen wash, engine oil)
 - Latest mileage
 - Range at current fuel level
 - Tire pressures
 - Next service due date

Vehicle Services Functions

Remote Status Alerts

To help prevent certain undesirable scenarios Remote Status Alerts are able to alert when action might need to be taken. For example, if a window has been left open, or a service due date is imminent.

10 minutes after each ignition off cycle, the vehicle will complete a vehicle status as above¹. If any item needs to be addressed a notification will be sent to the app.

Privacy mode

To promote privacy, a user must opt into the connected system before being able to access any connected car functions. Once opted in, a user will be guided through how their data is protected within our system. Industry standard cyber security protection is used on the Aston Martin cloud servers, as well as encryption of data sent between your vehicle and app.

Within the app, a user can choose to temporarily sever connection to the connected ecosystem. Privacy mode is activated through the infotainment system (Refer to 'System Settings', page 12.6).

Once disconnected, no data will be sent or received from the vehicle which can include:

- Online navigation support
- Geo-location data
- Customer contact centre calls

When Privacy mode is deactivated, full connected services will be reconnected from that point forward. No historic data will be sent once reconnected so that anonymity during Privacy mode is maintained.

¹. Excluding parking lamps, screen wash and engine oil level.

Over The Air (OTA) Updates

A key benefit of a connected car system is the ability to remotely update software and certain vehicle modules. This helps make sure that your vehicle always has the latest software levels installed without the need to visit an Aston Martin Dealer. OTA updates are checked for during each ignition cycle and will seamlessly be delivered through the integrated GSM connection.

When an update is available, the data package will download in the background and then notify on the infotainment screen when it is ready to install.

Subscriptions

A 3 year subscription is included with sale of your vehicle. In addition to this, a growing portfolio of individual paid features will be available. To manage subscription levels, a private section of the app is available to review, renew and cancel your current or future subscription packages.

Preferred Dealer

A preferred Dealer can be set within the app as a contact for information and service requirements. If you have any issues or queries about connected car or app functions contact your preferred Dealer.



Media Systems

Audio Specification.....	9.2
Now Playing	9.4
HD and Satellite Radio	9.5
Satellite Radio	9.10
Portable Media	9.15
Apple CarPlay	9.16
Sound Settings.....	9.18

Audio Specification

Bowers and Wilkins Audio

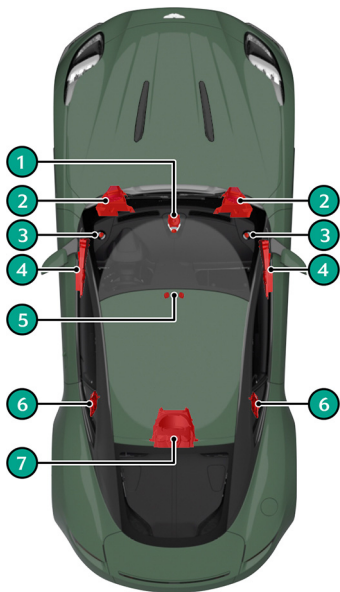

Speakers

[1] CENTRE SPEAKERS:

100 mm (4 inch) mid-range speaker with 25 mm (1 inch) tweeter.

[2] FOOTWELL WOOFERS:

165 mm (6.5 inch) woofers in enclosed cabinets.

[3] TWEETERS:

25 mm (1 inch) tweeters.

[4] DOOR SPEAKERS:

100 mm (4 inch) mid-range speaker in enclosed cabinet.

[5] MID-TWEETERS:

40 mm (1.5 inch) tweeters.

[6] REAR QUARTER SPEAKERS:

100 mm (4 inch) mid-range speaker with 25 mm (1 inch) tweeter.

[7] SUBWOOFER:

200 mm (8 inch) dual voice coil subwoofer.

Audio System Features

- 1170W Audio System
- QuantumLogic® Immersion Sound Processing₁
- Dirac LIVE®₂
- Vehicle Noise Compensation
- Audio Levelizer

₁ QuantumLogic® is a registered trademark of Harman

₂ Dirac LIVE® is registered trademark of Dirac Research AB

Aston Martin Audio System

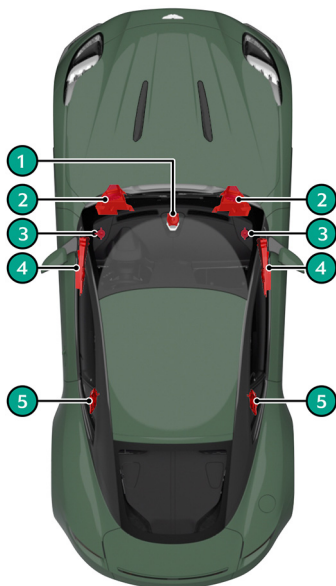

Speakers

[1] CENTRE SPEAKER:

100 mm (4 inch) mid-range speaker

[2] FOOTWELL WOOFERS:

165 mm (6.5 inch) woofer in enclosed cabinet.

[3] TWEETERS:

Two 25 mm (1 inch) tweeters.

[4] DOOR SPEAKERS:

100 mm (4 inch) mid-range speaker in enclosed cabinet.

[5] REAR QUARTER SPEAKERS:

100 mm (4 inch) mid-range speaker with 19 mm (0.75) inch tweeter.

Audio System Features

- 390W Audio System
- QuantumLogic® Sound Processing
- Vehicle Noise Compensation
- Audio Levelizer

Now Playing

The now playing screen has some common elements that appear regardless of which source medium is used. Individual media controls are explained in their relevant sections.

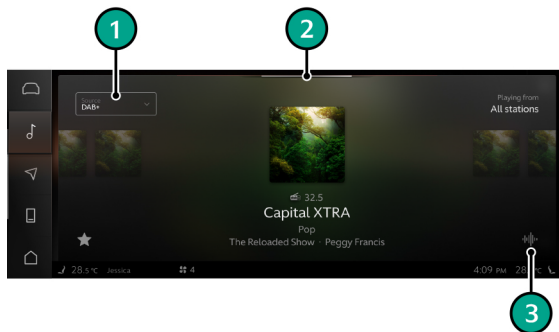

[1] SOURCE: Tap to change media source.

[2] MINIMIZE: Swipe down to minimize media screen to the bottom bar.

[3] SETTINGS: Opens the **Settings** menu (Refer to 'Sound Settings', page 9.18).

Source

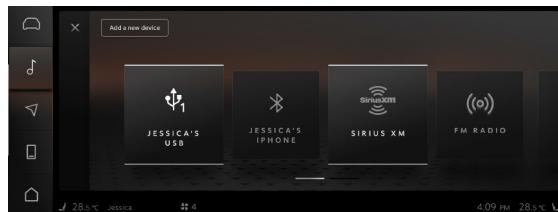

In the **Source** screen you can select from different media sources connected to the system or add more devices such as Bluetooth devices. To select a source, swipe along the row of options and tap on the required source.

HD and Satellite Radio

HD Radio

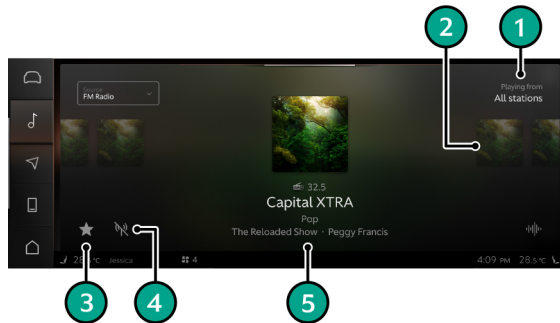

The display area will show the currently selected radio station and available radio stations.

[1] Radio Source: Location where radio station was selected from. Text clears after 2 seconds.

[2] Next Station: Shows artwork for the next radio stations (if available).

[3] Favorites: Tap to open the **Favorites** menu.

[4] Reception Warning: Warning symbol to show if there is weak reception signal.

[5] Station Information: Basic information about the selected radio station



HD Radio Technology manufactured under license from iBiquity Digital Corporation. U.S. and Foreign Patents. For patents see <http://dts.com/patents>. HD Radio, Artist Experience, and the HD, HD Radio, and "ARC" logos are registered trademarks or trademarks of iBiquity Digital Corporation in the United States and/or other countries.

SiriusXM

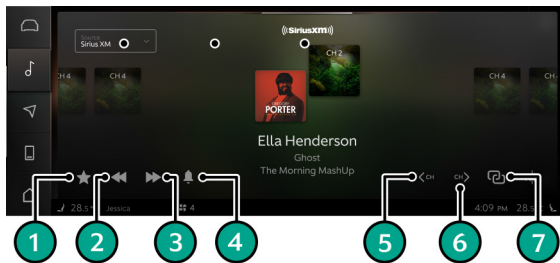

[1] FAVOURITE: Tap to add or remove from favourites (Refer to 'Favourites', page 9.10).

[2] SKIP BACK: Tap to skip to the start of the track or segment.

Press and hold to rewind through the available buffered audio.

[3] SKIP FORWARD: Tap to skip to the next track or segment.

Press and hold to skip to the live point of the current audio.

[4] NOTIFICATIONS: Tap to add the selected track or artist to the notifications list (Refer to 'Notifications', page 9.8).

[5] PREVIOUS CHANNEL: Tap to the previous channel and scroll the list.

Press and hold to scroll backwards through channels.

[6] NEXT CHANNEL: Tap to skip to the next channel and scroll the list.

Press and hold to scroll forwards through channels.

[7] RELATED: Tap to open related content to what you are currently listening to.



SiriusXM[®]₁ Satellite Radio offers 100% commercial-free digital quality radio channels for music, sports, news and entertainment.

Satellite or radio modes can be temporarily interrupted or unavailable for a number of reasons such as:

- Tunnels.
- Parking garages.
- Inside or next to buildings.

¹ Sirius, XM and all related marks and logos are trademarks of SiriusXM Radio Inc. and its subsidiaries. All other marks, channel names and logos are the property of their respective owners. All rights reserved.

Toolbar

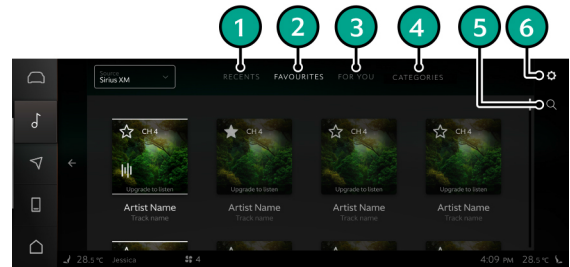

[1] RECENTS: Opens a folder of the most recently played channels and content previously listened to.

[2] FAVOURITES: Opens a list of saved favourite stations (Refer to 'Favourites', page 9.10).

[3] FOR YOU: Opens a list of suggested tracks or stations based on your listening preferences.

[4] CATEGORIES: Opens a menu of all available channels to a SiriusXM listener (Refer to 'Categories', page 9.8).

[5] SEARCH: Opens the search menu.

[6] SETTINGS: Opens the Satellite Radio Settings menu.

Categories

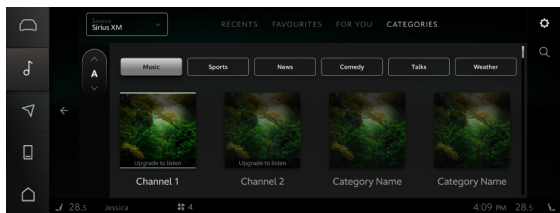

All Channels opens a list of all available content on SiriusXM. Results can be filtered by main category such as music or sports and then filtered by type such as music genre or sports covered.

Display results are listened alphabetically and can be scrolled with the scroll bar.

 *If a channel is not available with your subscription package this will be shown on the search result as 'upgrade to listen'.*

Tap on a channel in the results to play that channel.

Satellite Radio Settings

Notifications

Notifications can be given for favorite artists or songs so you know when they are being played on any SiriusXM channel. These can be set to on or off in the notifications menu.

The list of notifications will be shown in the notifications screen.

- Tap the icon to open the notification.
- Press and hold the icon to open the delete the notification.

Settings

- **Block Explicit**
Hide programming with explicit content.
- **Tune Start**
Start songs at the beginning when you tune a music channel.
- **Start Up Recommendations**
Get recommendations on start up and easily explore new content.
- **Reset History**
Reset listening history and recommendations.

System

- **Subscription**

Shows current subscription level. If no subscription is active press **Subscribe** to set up a subscription.

- **Information**

- **Radio ID**

Shows unique radio ID code for your device.

- **Version**

Shows software version level of your device.

- **Help and Support**

- **Help**

Directs to online help website

- **Support**

Shows the customer support number and your radio ID number for reference. To contact customer support, tap **Call SiriusXM**.

Subscription

Before setting up your satellite radio subscription you will need the Sirius XM® ID (Radio number) for your receiver. This can be found in the **Settings** menu under **System** along with a contact phone number which can be dialed directly from the infotainment system.

To register, call SIRIUS or go online:

North America:

Tel: 1-800-689-6881

<http://www.siriusxm.com>

Canada:

Tel: 1-888-539-7474

<http://www.siriusxm.ca>

Registration can take up to 10 minutes. When registration is complete, the message Updating Channels... will be shown followed by the satellite radio menu.

Favourites

The favourites menu shows a list of previously saved stations. If no stations have been saved, a window will be shown with a list of suggested stations to save. To select a station, swipe through the list of saved stations and tap the required entry.

To Add a Favourite

To add a station to the favourites list, tap on the station in the **Now Playing** screen, and tap . If the maximum numbers of favourite stations has been reached, you will be prompted to select a station to replace.

To Remove a Favourite

To remove a station from the favourites lists, tap .

Satellite Radio

Satellite or radio modes can be temporarily interrupted or unavailable for a number of reasons such as:

- Tunnels.
- Parking garages.
- Inside or next to buildings.

Sirius XM[®]₁ Satellite Radio offers 100% commercial-free digital-quality radio channels for music, sports, news and entertainment.

¹ Sirius, XM and all related marks and logos are trademarks of SiriusXM Radio Inc. and its subsidiaries. All other marks, channel names and logos are the property of their respective owners. All rights reserved.

Satellite Radio Registration

Before registering your satellite radio subscription you will need the Sirius XM® ID (ESN number) for your receiver. This can be found in the **Options** menu under **Service** along with a contact phone number.

To register, call SIRIUS or go online:

North America:

Tel: 1-888-539-7474

<http://www.siriusxm.com>

Canada:

Tel: 1-888-635-9632

<http://www.siriusxm.ca>

Registration can take up to 10 minutes. When registration is complete, the message *Updating Channels...* will be shown followed by the satellite radio menu.

Selecting a channel

Channel Browse

The display screen shows available channels that can be played.

Push the **CONTROL DIAL** with the centre display highlighted to browse channels.

Channel List Updates

If new channels become available, *Updating Channels...* is shown as a message on the display. Whilst updating, the last channel selected is set to mute until the update is complete and satellite radio will not be available. When the update is complete, the satellite radio menu will be shown again. If the last selected channel is still available, this channel will resume playing.

Satellite Radio Overview

On the lower information bar there will be the following options:

- Options
- Search
- Category
- Preset
- Band
- Information
- Sound

Options

Tag This Track¹

Select to store the track and music artist currently being played². Stored tracks can then be later purchased in the iTunes® store.

Music and Sports Alerts

An alert can be set for your favorite artists, tracks or sporting events³.

Once set, the infotainment system will continuously search through all channels. When a match to one of yours saved alerts is found, a window will show with any related information.

To Set A Music Alert

Select **Options** from the lower information bar and select **Alert for Artist, Track & Sports Event**.

Select **Add New Alert** and select either **Artist** or **Track**.

 *Music alerts can only be saved whilst a track is being played.*

1. Apple® devices only

2. Not supported by all radio channels.

3. Up to 30 alerts can be stored.

Music Alert

When a music alert is shown, select **Change to** to change the channel and the selected artist or track is played, or select **Ignore** and the current channel will continue playing

To Set a Sports Alert

Select **Options** from the lower information bar and select **Alert for Artist, Track & Sports Event**.

Select **Manage Sport Alerts** followed by **Select New Alerts**.

Choose a team from a league to set an alert for.

Editing music and sports alerts

Open **Alert for Artist, Track & Sports Event** to view a list of available alerts to edit.

Direct Entry

Opens a window to enter the frequency (AM/FM), channel (SiriusXM) or preset number for a radio station

Current Station List with Artist & Title

Select **Options** from the lower information bar and select **Current Station List with Artist & Title** to open the channel list. Scroll through the list with the **CONTROL DIAL** and press **ENTER** to select a channel

Service

The provider's customer service center is available by phone at any time to answer any general questions or questions on the versions available.

To select : turn and press the controller.

To select Service : turn and press the controller. The provider's details appear.

To return to the main display: press the % button.

Search

Select the search function  in the lower information bar to open the search window. Enter a search term and select a channel from the list of search results.

Category

Satellite radio channels are sorted into categories such as News/Discussions, Sports and Country (where available). Categories sorted alphabetically and category content is sorted by channel numbers.

Select **Category** on the lower information bar to view the category list. Select a category from the list to show all channels within that category

Presets

The centre display can be set to show stored preset stations instead of available stations.

To set preset view ON or OFF, select **Presets** from the lower information bar and select **Station Preset View**. Press **ENTER** to set ON or OFF.

Saved Preset Channels

Quick save:

Select the channel you wish to save. Press and hold **ENTER** until the preset list appears.

Rotate the **CONTROL DIAL** to select a preset number to save the channel to. A tone will confirm that the channel was successfully saved.

Saving a channel using the edit function:

Select **Preset** from the lower information bar and select **Edit Station Preset**. The list of saved channels will then be shown.

Press and hold **ENTER** on a selected preset number to save the current channel. This will overwrite any previously saved channel in the preset number slot.

 *There are 100 preset slots available.*

Band

Select between SiriusXM®, HD Radio FM and HD Radio AM.

Information

Select whether to show the available channels list or information about the current channel.

Information will be available such as:

- Channel logo
- Channel abbreviation
- Current track
- Current track artist

Sound settings

Opens the **Sound** menu screen

Portable Media

 Media files must be in .mp3 or .mp4 format to be recognized as a suitable file format.

USB

When a USB device is selected as a source medium, a song directory of available tracks will be given. From here you can also search by Album, Artist or Folders. You can also tap the  button to search content on the USB device.

Bluetooth

When a Bluetooth device is selected as a source medium, a folder directory of available tracks will be given. You can also tap the  button to search content on the Bluetooth device.

Now Playing

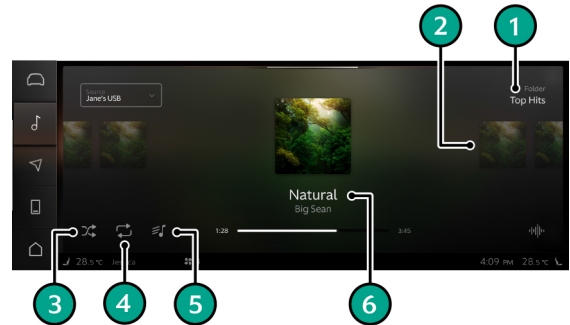

[1] SOURCE LOCATION: Shows the source location for the track being played from search path. For example, Folder, Artist or Album.

[2] NEXT TRACK: Tap to play the next track. Swipe to navigate through the playlist of tracks.

[3] SHUFFLE: Tap to shuffle to on or off to randomize the playlist.

[4] REPEAT: Tap to cycle repeat current track, repeat all tracks in the playlist or to set repeat to off.

[5] OPEN FOLDER/PLAYLIST: Opens the source folder for track or playlist.

[6] TRACK INFORMATION: Shows track information such as track name, artist, album and track play time. To skip to a time during the track tap and drag on the time progress bar.

Apple CarPlay

Apple CarPlay¹ enables an iPhone or other compatible Apple device to be used in the vehicle infotainment system and can be used to make calls, send and receive messages, view navigation and listen to music.

 *Not all features of Apple CarPlay are available in all regions. For a complete and up to date list of features and region availability, refer to the Apple website in your region.*

 *By using Apple CarPlay, you acknowledge the following: Apple CarPlay is a service provided by Apple Inc. under its terms and conditions. Aston Martin Lagonda is not responsible for Apple CarPlay or its applications. When using Apple CarPlay, certain information from your vehicle (such as its position) is transferred to your iPhone.*

 *Only one device can be connected for Apple CarPlay at a time.*

 *Only one navigation route can be active at a time. If a navigation route is set in the infotainment system, this will be closed when navigation is opened through Apple CarPlay.*

¹ Apple and Apple CarPlay are trademarks of Apple Inc., registered in the U.S. and other countries.

Initial Connection

 *Apple operating system version iOS 8.3 or above is required for Apple CarPlay to operate. An Internet connection is also required for the full range of app functions to operate.*

 *Apple CarPlay can only be set for the first time when the vehicle is parked.*

1. Connect the device to a USB port with a suitable cable.
2. Select **Connect** and **CarPlay** from the main infotainment menu.
3. The Apple CarPlay menu will now open.

Once the device has been connected for the first time, you will be presented with 2 options:

- **Automatic Start:**
Apple CarPlay will start automatically when a compatible device is connected to the infotainment system.
- **Manual Start:**
Manual start Apple CarPlay from the infotainment menu.

SIRI

Apple CarPlay apps can be voice operated using SIRI. To activate SIRI press and hold the  button.

 *Voice control can still be used to operate the vehicle infotainment system.*

Apple CarPlay Controls

 *Information about which apps are supported and which phones are compatible is available on Apple's Website www.apple.com/ios/carplay.*

CarPlay Options

- **Disconnect:**
Ends the CarPlay Session.
- **Connect Automatically:**
Set if CarPlay automatically starts when a compatible device is connected.
- **Sound:**
Open the *Sound* menu (Refer to 'Sound Settings', page 9.18).
- **Device List:**
Select the device to connect for Apple CarPlay.

Sound Settings

Aston Martin Audio System

Sound Focus

Sound Focus changes the optimisation of the speakers depending on how many occupants are in the vehicle.

Select from:

- **All Seats:**
Optimizes the speaker focus for all seats in the vehicle.
- **Driver:**
The sound is optimized for the driver only.
- **Surround Sound:**
Adjusts the EQ to provide surround sound.

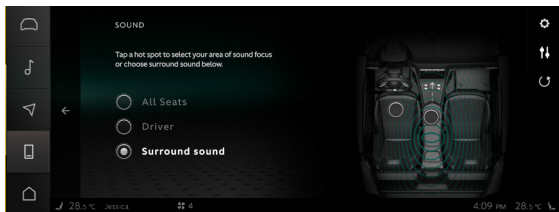

Bowers and Wilkins

Studio

Studio replicates the neutrality of a recording studio for the most accurate recreation of your music.

You can adjust the optimisation of the speakers depending on how many occupants are in the vehicle.

Select from:

- **All Seats:**
Optimizes the speaker focus for all seats in the vehicle.
- **Driver:**
The sound is optimized for the driver only.

Stage

Stage creates the sensation of an artist's stage right in front of you. Use the slider bars to adjust the level of Intensity and Immersion to simulate the size of virtual venue.

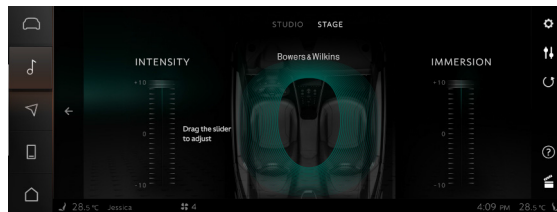

Equalizer

The equalizer screen allows the user to customize audio settings to their personal preferences.

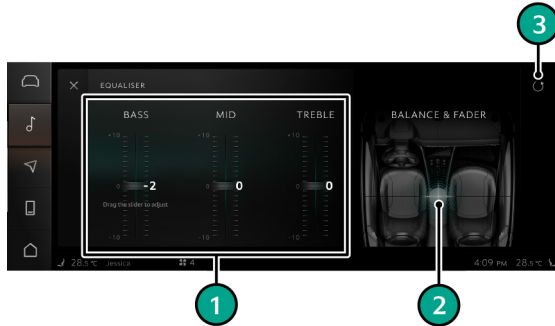

- **3 Band Equalizer:**
Touch and drag the sliders up or down to increase or decrease the bass, mid and treble frequency bands.
- **Balance and Fader:**
Touch and drag the crosshair to adjust the left to right balance and front and rear bias.
- **Reset:**
Resets settings to default.



Navigation

Safety Information.....	10.2
Map.....	10.3
Active Route.....	10.4
Navigation Settings	10.5

Safety Information

⚠ Warning: Failure to avoid the following potentially hazardous situations could result in an accident or collision resulting in death or serious injury.

⚠ Warning: Always use your best judgement, and operate the vehicle in a safe manner. Do not become distracted by the navigation system while driving, and always be fully aware of all driving conditions. Minimize the amount of time spent viewing the screen while driving and use voice prompts when possible.

⚠ Warning: Do not input destinations, change settings, or access any functions requiring prolonged use of the navigation system controls while driving. Bring the vehicle to a halt in a safe and legal manner before attempting such operations.

⚠ Warning: When navigating, carefully compare information shown on the screen to all available navigation sources, including road signs, road closures, road conditions, traffic congestion, weather conditions, and other factors that may affect safety while driving. For safety, always resolve any discrepancies before continuing navigation, and defer to posted road signs and road conditions.

⚠ Warning: The navigation software is designed to provide route suggestions. It is not a replacement for driver attentiveness and good judgement. Do not follow route suggestions if they suggest an unsafe or illegal manoeuvre or would place the vehicle in an unsafe situation.

Map



[1] SEARCH: Menu used to set navigation destinations.

[2] VEHICLE POSITION: Shows vehicle position and direction.

[3] SETTINGS: Tap to opens the navigation settings menu (Refer to 'Navigation Settings', page 10.5).

[4] CURRENT STREET NAME: Shows the current street/road name being travelled on.

[5] QUIBLA: Shows the direction to Mecca. Tap to show direction and time to next prayer in local time.

[6] MAP ORIENTATION/COMPASS: Shows direction to north. Tap to change map orientation so north is at the top of the screen.

[7] 2D/3D MAP: Tap to switch between 2D and 3D map view.

Map Browse

Some functions in the navigation system allow the user to find or select locations by scrolling the map directly.

Move the cursor by tapping and holding the touchscreen, and moving in the direction you wish to move the map. To zoom in and out of the map, use two fingers to touch the screen and pinch together to zoom out, or swipe apart to zoom in.

Search

The Search menu gives a number of options to be able to set a route for the navigation system.

Where to?

Tap *Where to?* to open the on screen keyboard to set an destination.

POI Icons

Tap on the icons to show that type of POI on the map. Tap  to expand the options available for POIs.

Planned

Tap to list routes that have been planned but not started.

Recents

Tap to show recently set destinations.

Home/Work

Tap to set destination to saved home or work address.

Favourites

Saved favourite destinations are shown at the bottom of the list.

Points of Interest (POI)

A POI can be set by selecting one from the search window, or tap and hold a point on the map.

A pop-up window will be shown that will display different information depending on the type of location.

Business

If the location is a business address, the window will show:

- Business name
- Business type
- If the address is open or closed
- Opening or closing time
- Call option to ring the business

Address

If the location is an address, the window will show the address, town name and postcode.

Location

If the location is not associated with a business or address, the window will give the nearest town or landmark name.

To set a destination, tap go on the pop-up window for the chosen destination.



Active Route



[1] LANE/TURN NOTIFICATION: Pop-up window showing where the next turn or lane change is along with the distance to the turn.

[2] ROUTE: Shows the active route being followed in blue. Optional roads along the routes will be shown in grey.

[3] JOURNEY INFORMATION: Shows the estimated arrival time, journey time remaining and distance remaining. Tap **Cancel Route** to end the selected route navigation.

Tap  to enter an address for an additional stop on the route. If multiple stops are added, tap  to set the order for the stops on the route.

Navigation Settings

Map Software

Shows the current level of map software and GPS status. If an update is available, this will also be shown.

- **GPS Status:**
Shows if a GPS signal is available or not.
- **Map Version:**
Shows the current map software version.

Traffic and Map Display

- **Show real time traffic information:**
Set if live traffic information is used from the internet.
- **Show Mecca direction on the map:**
Tap set if the direction to Mecca is shown on the map¹.
- **Automatic re-routing:**
Tap to set if the route is redirected if a quicker or more efficient route becomes available.
- **Customize POIs shown on map:**
Select a series of POIs to be included on the map.
- **Show current street name:**
Tap to set if the current street name is shown on the display.

Sound & Voice

Sets volume and audio functions for the navigation system.

- **Voice Guidance Volume:**
Adjust the volume of navigation guidance prompts.
- **Play Voice Guidance Over Music:**
Set if navigation guidance prompts are given when music is playing.
- **Play Voice Guidance During Phone Calls:**
Set if navigation guidance prompts are given when a phone call is active.
- **Default Voice Guidance Level:**
Choose between *Full*, *Alerts Only* or *Mute*.

¹. Not available in all markets

Route Criteria

Shows a list of filters that can be applied to the navigation system when routes are set.

- **Avoid Motorways:**
Excludes sections of routes that use motorways or freeways.
- **Avoid Toll Roads:**
Excludes sections of routes that go through toll roads.
- **Avoid Ferries:**
Exclude sections of routes that include ferry travel.
- **Avoid Trains:**
Exclude sections of routes that include train travel.
- **Avoid Congestion Zone:**
Exclude sections of routes that go through congestion zones.
- **Avoid Tunnels:**
Exclude sections of routes that go through tunnels.

History & Destinations

Shows saved address and search history.

- **Home Address:**
 - **Add/Edit:** Add or edit details for a set home address.
 - **Delete:** Removes the set home address.
- **Work Address:**
 - **Add/Edit:** Edit details for the set work address.
 - **Delete:** Removes the set work address.
- **Manage Favourite Destinations:**
Opens a list of saved favourite destinations where individual entries can be deleted.
- **Clear Search History:**
Clear all search entries in the navigation system.
- **Clear Destination History:**
Clear all set destinations in the navigation system.

Convertible Roof

Roof Operation.....	11.2
Roll-Over Protection System.....	11.4
Wind Deflector	11.6
Emergency Roof operation	11.8

Roof Operation

⚠ Warning: Before raising or lowering the roof, make sure that all occupants are clear of the tonneau panel, the windscreen frame and door windows.

⚠ Warning: Misuse of the roof switch, especially by children, can result in injury due to entrapment in the roof mechanism and locking points.

⚠ Caution: Aston Martin recommend that the roof is not operated at temperatures of 0°C and below.

⚠ Caution: Make sure that the roof is always fully raised or fully lowered.

⚠ Caution: Do not attempt to lower the roof if any objects or clothing are laying on top of the roof or tonneau panel.

⚠ Caution: Before closing or opening the roof, make sure that there are no objects placed on the rear sloping deck area which could interfere with the folded, stored roof, especially the heated rear windscreen glass. Even small objects can cause damage.

⚠ Caution: Continuous use of the roof without the engine operating will cause the vehicle battery to rapidly discharge.

To Operate The Roof

⚠ Warning: Keep the vehicle road speed down to a minimum until the roof has completed its operation.

⚠ Caution: Aston Martin recommend that the roof is only operated while the vehicle is stationary and that the engine is always running when operating the roof mechanism to maintain optimal battery performance.

🔒 The deck lid will lock and will stay locked during roof lowering and raising operations.

Before operating the convertible roof:

- The deck lid must be closed.
- The ignition must be on and the engine must be running.
- Outside temperature must be above -10°C.
- The variable load device must be in the lower position.
- A maximum headroom (A) of 1795 mm is available for the roof to raise or lower.



Operation

⚠ Warning: *If roof movement is not complete the message "Open/close top completely" will be shown in the instrument cluster.*

To operate the roof use the switch (A) in the centre console.



To Lower the Roof: Pull and hold the switch backwards to lower the roof.

To Raise the Roof: Push and hold the switch forwards to raise the roof.

Once roof movement is complete, a confirmation sound will be heard from the instrument cluster.

Window Operation

The windows are operated independently of the roof. Use the window switch to operate the windows as normal.

Roof Relaxation

The roof system continually monitors the roof position. If the roof is in a position between fully open and fully closed for 7 minutes with the ignition on, the roof will close. There will be a warning sound and the roof will relax and close to its stowage position in its lowest position.

📖 *If the key is removed from the vehicle ignition, the roof system will not wait the 7 minutes and will close after the audible warning.*

⚠ Warning: *The roof can fall rapidly as the roof system loses hydraulic pressure. Keep away from the roof mechanism when the audible warning begins, to prevent injury or entrapment.*

Over-speed Operation

Vehicle speed should be below 55 km/h (34 mph) when the roof is operated.

If the vehicle speed exceeds 55 km/h (34 mph), the convertible roof will stop opening or closing. This can restrict the view from the rear of the vehicle and can cause an accident. Reduce the vehicle speed to below 50 km/h (31 mph). Press the roof switch again to continue roof operation.

When safe to do so, continue the roof movement. If the roof is left in it's paused position for seven minutes, hydraulic pressure will be lost in the roof mechanism. The roof and tonneau lid will relax and drop down.

Roll-Over Protection System

⚠ Warning: Do not attempt to service or modify the deployable roll-bar system.

⚠ Warning: Do not allow any person to sit on the deployable roll-bar covers at any time.

⚠ Warning: Do not place any objects on the top of the deployable roll-bar covers.

⚠ Warning: Do not attempt to reset the deployable roll-bar system after it has deployed.

⚠ Warning: Do not attempt to raise or lower the roof after the deployable roll-bar system has deployed.

⚠ Caution: If the roof is raised the deployable roll-bars will break through the rear glass.

⚠ Caution: Extreme manoeuvres may cause the vehicle system to predict a roll-over event and activate the roll-over protection system. If such driving is anticipated by the customer (track day driving, for example) the roof should be fully lowered so the roll-bars can be deployed without damaging the vehicle.

The roll-over protection system has electronic sensors mounted to the vehicle body that monitor and determine if a roll-over has taken place. If the system senses a rollover, two roll bars mounted under trim panels in the tonneau lid, will deploy to protect vehicle occupants.

 *If the roll-bars are deployed the door mounted airbags will also be deployed to further protect vehicle occupants.*



Warning Labels

Do Not Cover is embossed into tonneau cover above the roll bars.

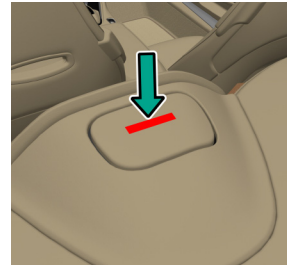

Wind Deflector

The wind deflector can be used to greatly reduce wind turbulence when the roof is lowered. It is easily installed to mounts in the vehicle and can be left in place with the roof raised or lowered.

⚠ Caution: *Take care when adjusting the driver or passenger seat position with the wind deflector installed. Make sure that the seats do not come into contact with the wind deflector.*

Storage

The wind deflector can easily be folded and stowed away when not used. When the wind deflector is not required, remove it from the vehicle and place it in the storage bag. Place the storage bag in the vehicle luggage compartment.

Installation

To install the wind deflector:

1. Remove the wind deflector from the storage bag.
2. Unfold the base panels.



3. Open the main net panel and join the two base panels with the snap connectors.

⚠ Caution: Do not try to join the base panels with the snap connector before folding down from their stored position. If you do, you will damage the snap connectors.

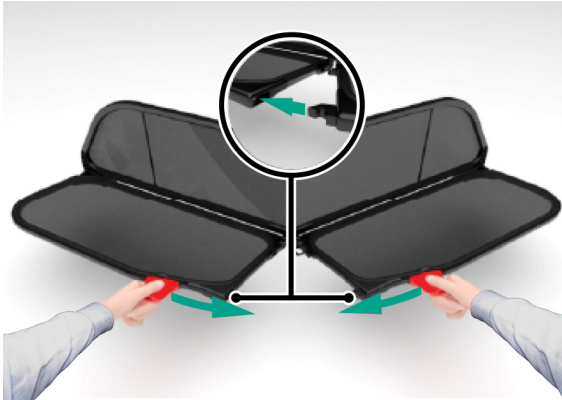

4. Insert the two locating tabs into the rear seat belt openings. Use the two slide bolts to lock the wind deflector above the rear seats.

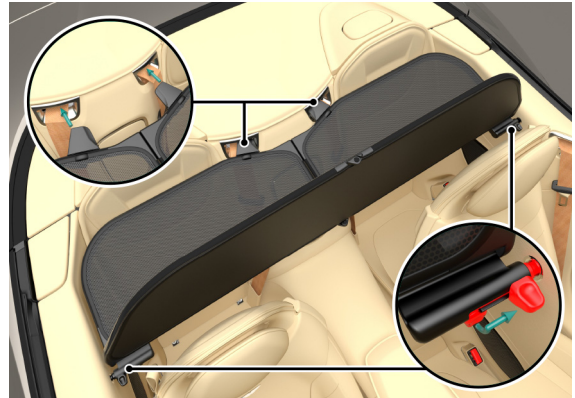

When the wind deflector is installed it can be used in the raised or lowered position. Grab the top bar of the wind deflector to raise or lower the panel until it clicks into position.

⚠ Caution: Do not use the wind deflector to store items. This can cause damage to the wind deflector such as a rip in the net area.

⚠ Caution: Do not grab the main net panel. Sharp objects can pierce or otherwise damage the net.

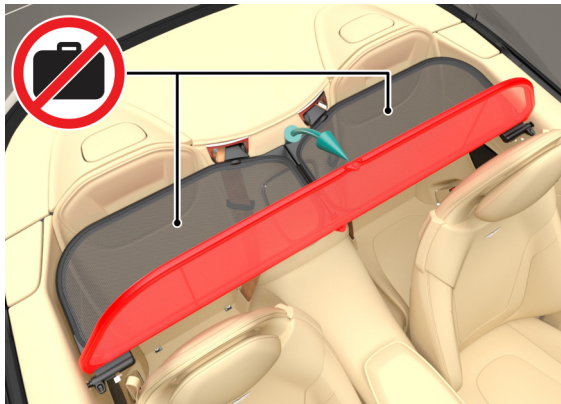

Removal

To remove the wind deflector, do the installation procedure in reverse.

Emergency Roof operation

In the unlikely event of the roof failing, it can be manually raised and locked.

⚠ Warning: Make sure the ignition is set to off before you begin this procedure. This will prevent accidental operation of the roof which can cause injury.

⚠ Warning: Aston Martin recommend that a minimum of two people are required to manually raise and lock the roof. The roof mechanism will move very slowly when being raised manually.

⚠ Warning: Keep fingers clear of the roof linkage when moving the roof manually.

⚠ Caution: Vehicle Security: If the roof fails, always raise and lock the roof. Do not lower the roof as tonneau lid locks will not be available.

📖 If the roof fails in the stored position it can stay stored and locked if required. Contact your Aston Martin Dealer.

📖 If the roof fails after the tonneau locks have been released the message "Open/close top completely" will show in the instrument cluster and a continuous audible warning will sound until the roof has been locked in the raised position.

To Raise the Roof

 Once the manual roof raise procedure is complete, you will not be able to operate the convertible roof until it has been reset by an Aston Martin Dealer.

1. Remove the wind deflector (if installed).
2. Remove the head rests (A) for the rear seats.

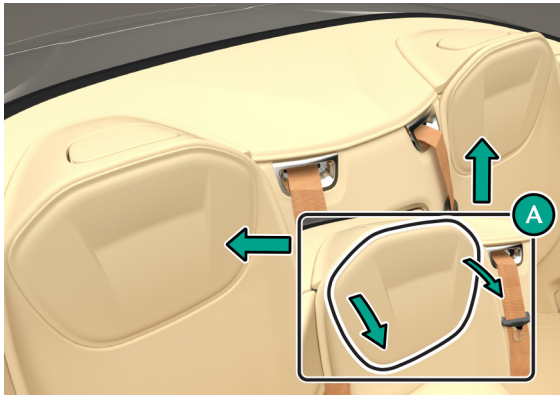

3. Remove the roof emergency tool (B) and put to one side. This will be needed to lock the roof.

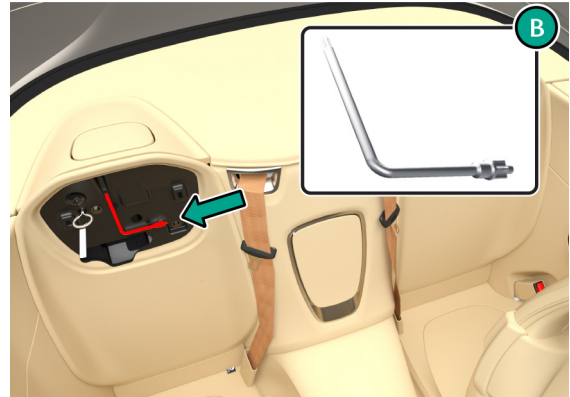

11.10 Convertible Roof

4. Pull the two release cables (C) for the tonneau latches.



5. Lift the tonneau cover at the points shown.

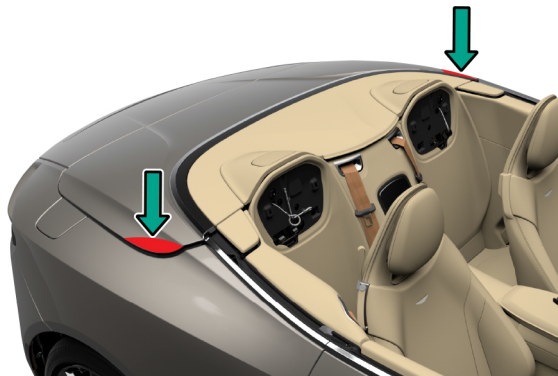

6. Push the hinge pivot (D) rearward to lock the tonneau into position.

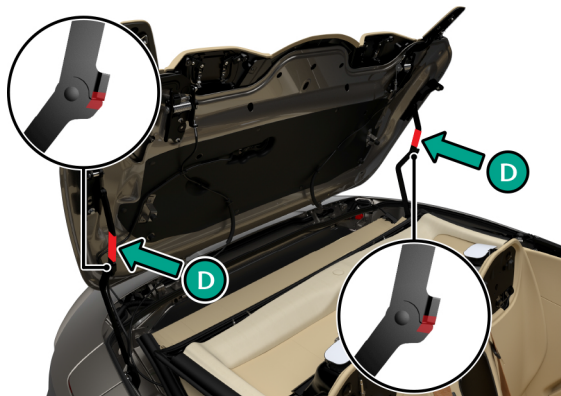

7. With a person each side, support the tension bow (E) and fully lift the roof to its closed position.

! Caution: The tension bow must not be allowed to fall until the front latches for the roof are in their receivers. If the tension bow does fall back before this point, the inner lining for the roof will be damaged.

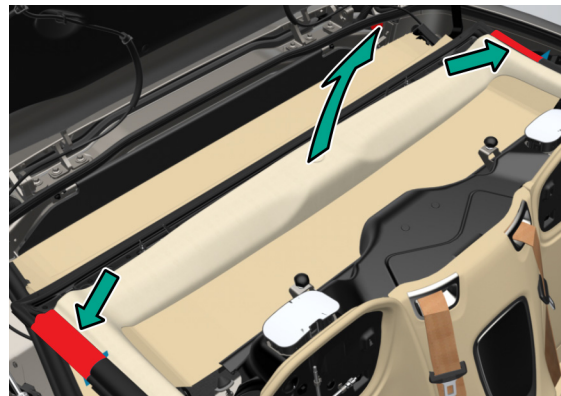

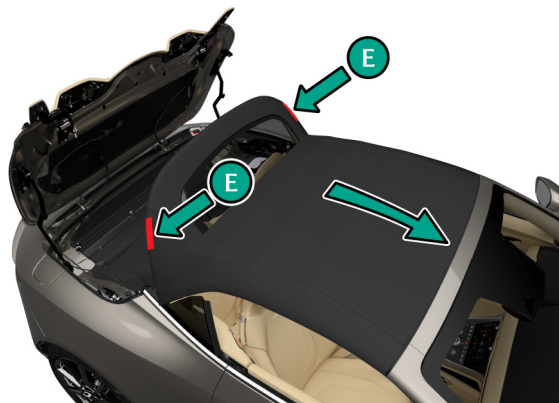

8. Whilst supporting the tension bow, unlock the hinge and close the tonneau cover.

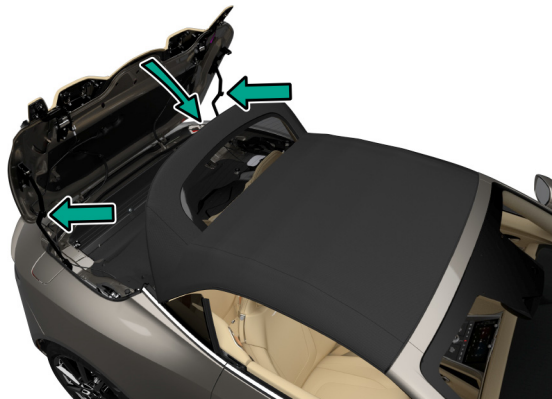

-
9. Once the tonneau cover is fully closed, lower the tension bow.

⚠ Caution: Do not allow the tonneau lid to rest on the roof fabric.



10. Inside the vehicle, remove the trim plug from the front header panel.

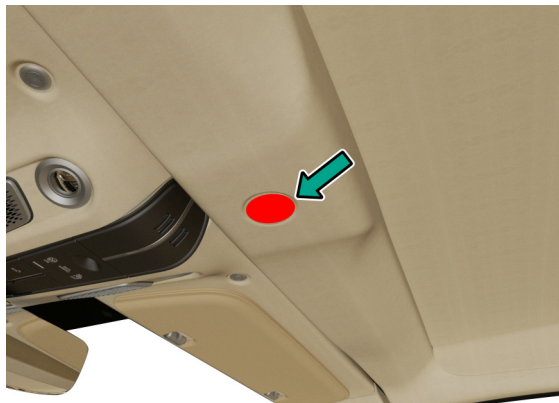

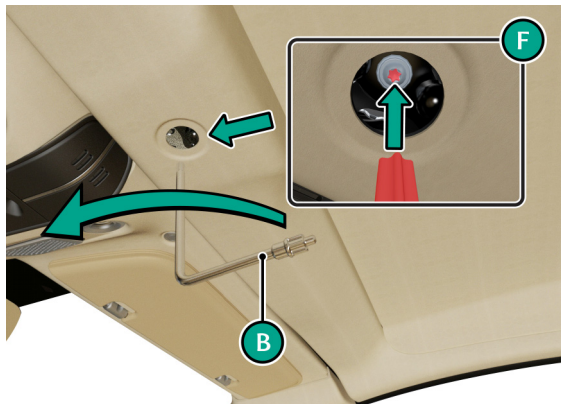

11. Use the small end of the roof emergency tool to remove the screw (F) from the roof motor.

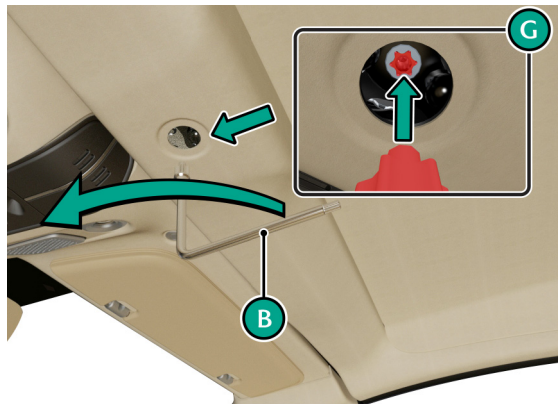

12. Use the large end of the roof emergency tool to disengage the drive spline (G) and turn the motor one turn counter-clockwise.

 You must contact your Aston Martin dealer to reset the drive to the roof latch motor.



 If the roof is manually raised or lowered, both the tension bow and the tonneau cover cannot be locked.

Vehicle and System Settings

Vehicle	12.2
System Settings	12.6

Vehicle

To access the **Vehicle** menu tap . You will be shown the below options:

- **Drive Modes:**
Opens the **Drive modes** menu.
- **Telemetry:**
Opens the **Telemetry** menu.
- **Assistance:**
Opens the **Assistance** menu.
- **Lights:**
Opens the **Lights** menu.
- **Vehicle:**
Opens the **Vehicle** menu.
- **Parking:**
Opens the **Parking** menu.

Drive Modes

The **Drive Mode** screen shows which drive mode the vehicle is currently set to. This is also where the parameters for the *Individual* drive mode can be set.

To set *Individual* mode, rotate the drive mode dial in the centre console to **Individual** and select **Personalize**.¹

Select from:

Powertrain				
Drive	Wet	GT	Sport	Sport+
Exhaust	GT	Sport	Sport+	

Drive Dynamics			
Steering	GT	Sport	
Suspension	GT	Sport	Sport+

¹ If Individual mode parameters have already been set, **Personalize** will change to **Edit**.

Telemetry

The **Telemetry** screen shows auxiliary engine information to support the main instrument cluster. There are on screen dials that show:

- Battery Voltage
- Engine Power
- Engine Torque
- Engine Oil Temperature

Assistance

The **Assistance** menu is used to control the behaviour of the various driver aid systems this vehicle is equipped with.

Adaptive Cruise Control

Choose between *Automatic* and *Manual* legal speed limit adoption.

Automatic Emergency Braking

Choose to set Automatic Emergency Braking on or off.

Sensitivity

Choose to set the sensitivity level of the Automatic Emergency Braking to *Early*, *Medium* or *Late*.

Blind Spot Assist

Set Blind Spot Assist to on or off.

Traffic Sign Assist

Choose to set Traffic Sign Assist to *Visual*, *Visual & Audible* or *Off*.

Speed Limit Change Audio Warning

Select if an audible warning is given when the speed limit changes for the road the vehicle is being driven on.

Lane Keep Assist

Lane Keep Assist (LKA)

Choose to set LKA to on or off.

Lane Departure Warning (LDW)

Choose to set LDW to on or off.¹

Rear Cross Traffic Assist

Choose to set Rear Cross Traffic Assist to on or off.

Lights

The **Lights** menu is used to set parameters for the various lighting systems on the vehicle.

- **Ambient Lights:**
Open the **Ambient Light** menu.
 - **Colour:**
Use the slider bar to select a colour.
 - **Brightness:**
Use the slider bar to set a brightness for the cabin.
- **Courtesy Lights:**
Set the courtesy lights to turn on or off.
- **Exterior Light Shut-off Timeout:**
Adjust how long the exterior lamps stay lit when the vehicle ignition is switched off.
- **Interior Light Shut-off Timeout:**
Adjust how long the interior lamps stay lit when the vehicle ignition is switched off.

¹. Only available to select if LKA is set to off.

Vehicle

The **Vehicle** menu is used to set parameters for various systems on the vehicle.

Comfort

- **Acoustic Lock:**
Set if the vehicle audibly confirms when it is locked.
- **Automatic Door Lock:**
Set to lock the vehicle doors when the vehicle is driven above 15 km/h (9 mph).
- **Automatic Mirror Folding:**
Set so that the mirrors fold in when the vehicle is locked.
- **Easy Entry/Exit:**
Set if the easy entry function is set to move *Seat and steering wheel*, *Only steering wheel* or *Off*.
- **Interior motion sensor:**
Sets the interior motion sensors for the alarm on or off.
- **Tow-Away Protection:**
Sets the vehicle tilt sensor for the alarm on or off.

Miscellaneous

- **Standby mode:**
Set the vehicle into standby mode where non-essential systems are shut down to extend battery life when the vehicle is not used for extended periods of time.
- **Winter tires limit:**
Sets a maximum vehicle speed for when winter tires are fitted.

Parking

The **Parking** menu is used to set parameters for the parking systems on the vehicle.

- **Audio Fadeout Warning Tones:**
Set if warnings fade out with distance from an obstacle.
- **Warning Volume Tones:**
Sets the volume for when warnings are given.
- **Warning Tone Pitch:**
Sets the pitch for when warnings are given.
- **Automatic Reversing Camera:**
Set if the parking camera is automatically shown when reverse gear is selected.

Visual Warnings

- **Front:**
Sets if warnings are shown for obstacles to the front of the vehicle at a standard distance or early.
- **Rear:**
Sets if warnings are shown for obstacles to the rear of the vehicle at a standard distance or early.
- **Side:**
Sets if warnings are shown for obstacles to the side of the vehicle at a standard distance or early.

System Settings

To access the **System Settings** menu, tap  to view the home screen and swipe right to view the menu. Select

 to open **System Settings** and view the below options:

- **Apps:**
Opens the **Apps** menu to adjust settings for individual apps.
- **Audio:**
Opens the **Audio** system settings menu.
- **Device Manager:**
Open the **Device Manager** menu for connected devices (Refer to 'Bluetooth Device Management', page 7.2).
- **Display:**
Opens the **Display** menu to adjust visual content.
- **Language & Units:**
Opens the **Language & Units** menu to set system language and units used.
- **Privacy Mode:**
Temporarily deactivate all connected car functions and remote car controls.

- **Reset:**
Restore the vehicle software systems to their factory settings¹.
- **Software:**
Shows system software version and used to update the software.
- **Time & Date:**
Opens the **Time & Date** menu.
- **Bluetooth Name:**
Opens the **Bluetooth** screen to set Bluetooth to on or off, and to set the vehicle's Bluetooth name.

¹ Only available whilst vehicle is stationary.

Apps

Sets display parameters for the instrument cluster and infotainment system.

- **Navigation:**
Opens the **Navigation** settings menu (Refer to 'Navigation Settings', page 10.5).
- **Phone:**
Opens the **Phone** settings menu.

Audio

Sets audio parameters for the infotainment system.

- **Auto Volume Adjustment:**
Set if the system automatically adjust volume to compensate for exterior noise.
- **Navigation Guidance Volume:**
Set the volume for navigation announcements.
- **Incoming Ringtone Volume:**
Sets the ringtone volume.
- **Default In-Call Volume:**
Set what volume calls are at by default¹.

Radio

- **HD Radio:**
Set if the HD radio system is available in the infotainment system.
- **Traffic Announcements:**
Set if traffic announcements are active in the navigation system.

¹. Call volume can be changed during calls.

Display

Sets display parameters for the instrument cluster and infotainment system.

- **Auto Display Brightness:**
Set if the display screens automatically adjust brightness.
- **Display Brightness:**
Manually set the brightness level for the display¹.
- **Display Theme:**
Set if the display screens are set to *Light*, *Dark* or *Auto* mode.

Language & Units

System Language

Sets the language used for the instrument cluster, infotainment system and warnings.

Speed Unit

Sets the units used for vehicle speed.

Temperature Unit

Sets the units used for temperature displays.

Pressure Unit

Sets the units used for pressure displays.

Fuel Consumption Unit

Sets the units used for displaying fuel consumption.

Software

The **Software** page shows the software levels for the below components and if the software is at it's most up to date level. If a software update is available, this will be shown as a pop up notification at the top of the menu (Refer to 'Software Updates', page 13.61).

- Software Version
- Part Number
- Boot Loader Version

¹. Only available if Auto Display Brightness is set to off.

Time & Date

- **Set Time Automatically:**
Select to automatically set the time and time zone.
 - **Manual time**
If **Set Time Automatically** is set to off, the time can manually be set.
- **Time Format:**
Set if the time format is given as 12 or 24 hours.
- **Date Format:**
Set how the date format is shown.





Maintenance and Technical Data

Introduction	13.2
Servicing Precautions.....	13.3
Owner Maintenance Checks	13.5
Bonnet Release	13.6
Fluid Checks and Capacities.....	13.8
Washers and Wipers	13.13
Chassis Systems.....	13.14
Wheels and Tyres	13.16
US Department of Transportation	13.21
Electrical Systems.....	13.29
Vehicle Care	13.39
Powertrain Specifications	13.46
Performance	13.47
Dimensions	13.48
Emergency and Breakdown	13.51
Fuel.....	13.59
Software Updates	13.61

Introduction

Due to the sophistication of the various systems and the specialized equipment required to maintain this vehicle, owner maintenance should be restricted to the routine procedures described in this chapter.

If you think that this vehicle is not functioning correctly, please contact an Aston Martin Dealer for the vehicle to be professionally checked.

Parts and Lubricants

Aston Martin recommends that when performing a servicing task, the recommended lubricants (Refer to 'Fluid Checks and Capacities', page 13.8) and parts are used.

⚠ Caution: *If oils or lubricants are used which do not meet the required fluid specification, vehicle components may experience excessive wear, a build-up of sludge and deposits or cause increased pollution. If it is evident to Aston Martin that use of products other than those which are recommended by the manufacturer have caused damage to the vehicle or engine, Aston Martin may refuse to authorize the repair of such damage under the terms of the manufacturer's warranty.*

Electronic Fuel Injection

⚠ Warning: If the fuel system is allowed to run dry, the fuel pump(s) can be permanently damaged.

⚠ Warning: Any modifications or additions to the fuel system not specifically designed by Aston Martin are prohibited. If installed, they can cause damage to the fuel system which, in some circumstances, could cause fire. All Service Action and Safety Recall Actions must be undertaken by an Aston Martin Dealer.

The electronic fuel injection system requires specialist equipment and test facilities to set up and maintain so that the vehicle gives maximum performance, coupled with economy, reliability and safe vehicle emissions. You are, therefore, strongly advised to entrust all service work to an Aston Martin Dealer.

Restraint Systems

Aston Martin recommend that the inflatable restraint systems (airbags) and seat belt components installed to this vehicle are replaced at 10 year intervals from the date of manufacture on the certification label.

Emission Warranty

The emission control systems installed to vehicles for certain markets are covered by a separate warranty. A statement of the provisions is given in the Warranty section of this Owner's Guide. You are advised to familiarize yourself with all warranty conditions at the earliest opportunity after taking delivery of your vehicle.

Servicing Precautions

To avoid personal injury, the following safety precautions must be observed when the hood is open and the engine is operating or the ignition is on.

⚠ Warning: Protect yourself against dangerous substances.

⚠ Warning: Keep hands, hair, tools, items of clothing and jewellery clear of all drive belts, pulleys and operating mechanisms. The cooling fan may operate even though the engine is not operating.

⚠ Warning: Avoid skin contact with all exhaust system and engine components, engine fluids and escaping steam. They may be hot and can cause scalding or burns.

⚠ Warning: Any loose objects, such as ties, should be removed before working on a vehicle. Any jewellery should also be removed before working on a vehicle, especially work on the electrical system.

⚠ Warning: Catalytic converters convert harmful exhaust gasses into less noxious substances and so reduce environmental pollution. They operate at high temperatures and continue to radiate a considerable amount of heat after the ignition has been set to off.

⚠ Warning: Do not breathe exhaust fumes. Exhaust fumes contain carbon monoxide. Carbon monoxide is a dangerous gas, which is colourless and odourless and can cause unconsciousness and may be fatal. Never start or leave the engine running in an enclosed, unventilated area.

⚠ Warning: Do not work beneath the vehicle with a vehicle lifting jack as the only support. Place suitable stands under the vehicle.

⚠ Warning: Keep children and pets clear of the vehicle. Do not let anyone inside the vehicle unless specifically working to your instructions.

⚠ Warning: Whenever possible, work in the engine compartment with the engine cool, the ignition off and the vehicle battery disconnected.

⚠ Warning: Petrol is highly flammable and, in confined spaces, is also explosive and toxic. In the event of spillage, set the engine to off. Do not use a flame or spark near fuel or fuel vapour. Do not smoke near fuel or fuel vapour. Do not inhale fuel vapour or fumes.

Dangerous Substances

⚠ Warning: Dangerous substances should be kept out of reach of children.

⚠ Warning: Many liquids and other substances used in motor vehicles are poisonous and should under no circumstances be consumed and should, so far as possible, be kept from contact with the skin. These substances include battery electrolyte, antifreeze, oil, brake and clutch fluid, petrol, windscreen washer additives, lubricants, refrigerant and various adhesives.

⚠ Warning: Particular care should be taken to avoid unnecessary contact with used engine oil. Always read carefully the instructions printed on labels or stamped on components and follow them carefully. Such instructions are included for reasons of your health and personal safety. Never disregard them.

Owner Maintenance Checks

Engine Oils

⚠ Warning: *Prolonged and repeated contact with used engine oils can cause serious skin disorders, including dermatitis and cancer. Avoid excessive contact, wash thoroughly after contact. Keep out of reach of children. When your oil is changed, be sure that it is done by an experienced person. In addition, observe all laws regarding the disposal of waste oil and toxic fluids.*

Protect The Environment

⚠ Warning: *It is illegal to pollute drains, water courses, or soil. Use authorized waste disposal facilities, including civic amenity sites and garages providing facilities for receipt of used oil. If in doubt, contact your local authority for advice.*

In the interests of safety and reliability, it is advisable to carry out the following checks at the intervals suggested (more frequently if your vehicle is heavily used or operating in adverse conditions), and always before starting on a long journey. Refer to the following pages for advice and check procedures.

Before Use Check:

- Operation of lamps, horn, indicators, wipers, washers and warning symbols
- Check there is sufficient fuel for the intended journey, particularly at night and before entering motorways
- Operation of the seat belts
- Operation of the brakes
- Check for fluid deposits underneath the vehicle.

Weekly Checks

(daily if driving large distances or touring)

- Tire condition
- Coolant level
- Brake fluid level
- Air conditioning operation
- Windscreen washer fluid level
- Check operation of windscreen washers.

Fuel Filler Bowl

During fuel filling check that the fuel filler bowl drain pipe is free from debris which may block the pipe. If the pipe is blocked, water can not drain from the bowl and can overflow into the fuel tank.

Engine Oil Level

⚠ Caution: *It is important to check the engine oil level regularly. Running the engine with engine oil below the lower mark or above the upper mark can cause serious engine damage.*

Check the engine oil level every fourth fuel tank fill or weekly - whichever is the sooner .

Tool Kit

The following emergency items are located in stowage box tool kit in the luggage compartment.

- First aid kit (optional).
- Warning triangle.
- Tire repair kit which also holds:
 - Towing eye
 - Funnel for emergency fuel fill
 - Locking wheel bolt key (optional)

Hood Release

To open the hood, pull the lever (A) located under the instrument panel to release the hood latch. The hood will rise but stay secured by the hood secondary catch.



 *The hood release lever is always on the passenger side of the instrument panel.*

Slightly lift the front edge of the hood and move the hood secondary catch to release it. Lift the hood until fully open. The hood is held open by two gas struts.

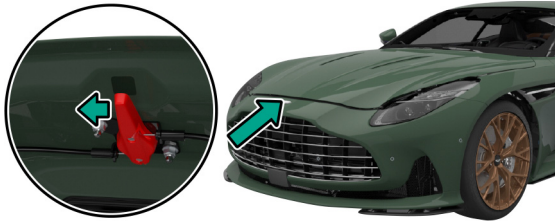

To close the hood, lower the hood until it starts to fall under its own weight, then let the hood fall to close. If the hood does not shut, open the hood again and repeat with light hand pressure as the hood falls.

⚠ Warning: The two secondary latches on the hood are sharp. Take care to avoid personal injury when under the hood.





Fluid Checks and Capacities

Engine Oil Level

 **Warning:** *Engine oil or components may be hot and could cause severe burns.*

 **Caution:** *Running the engine with engine oil below the lower mark or above the upper mark can cause serious engine damage.*

 **Caution:** *This vehicle's warranty may be invalidated if damage is caused by the use of incorrect engine oil. Low quality or obsolete oils do NOT give the protection required by modern, high performance engines.*

 **Caution:** *Failure to use engine oil that meets the required specification can cause excessive engine wear, a build up of sludge and deposits, and increased pollution. It could also lead to engine failure.*

Engine Oil Level Sensing

This vehicle has an electronic engine Oil Level Sensing (OLS) system which records the engine oil level every vehicle start if the vehicle has been left for 4 or more hours, if the vehicle is on level ground, and if it is within a pre-set oil temperature range.

 **Caution:** *Running the engine with engine oil below the minimum level can cause serious engine damage.*

 *The system may not record an oil level if the engine oil temperature is low.*

If the engine oil level is approaching the minimum mark, a message will be shown in the instrument cluster along with a warning symbol. A code will also be stored in the engine management system. The engine oil level should be checked and filled to the required level engine oil as soon as possible. The message will clear when the oil level is filled with a least 1 litre to the required level and the OLS system has performed a valid check of the oil level.

Engine Oil Level Check

 The engine can use up to 0.8 litres of oil for every 1000 km (620 miles) once the engine has completed 10,000 km (6200 miles).

1. Make sure the vehicle is on level ground.
2. Run the engine until it reaches normal operating temperature.
3. Navigate to *Service* and then *Oil Level Check* in the instrument cluster menu.
4. If more oil is required, shut off the engine, remove the engine oil filler cap and top up with the recommended engine oil (Refer to 'Engine Oil', page 13.12).
5. Wait for approximately two minutes for the engine oil to settle, then repeat step 3. Add engine oil if required. **Do not overfill.**
6. Securely fit the engine oil filler cap.

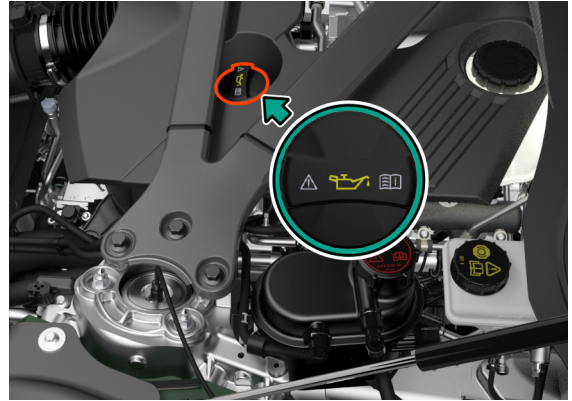

Engine Coolant Level

⚠ Warning: Do not remove the filler cap until the coolant system has cooled. Scalding can be caused by escaping steam or coolant.

📖 Use a cloth or glove to protect hands and protect face and arms adequately.

1. Remove the reservoir cap to check the coolant level. The correct coolant level is to the top of the reservoir tank.

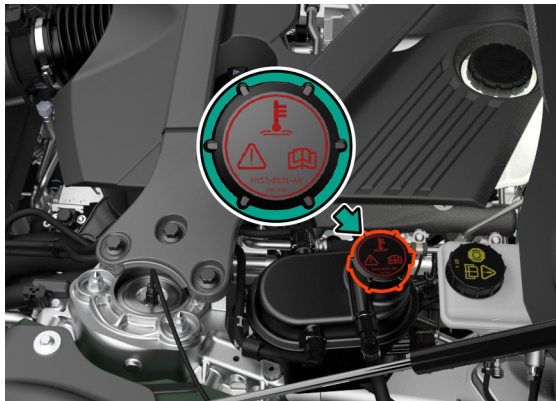

2. Make sure that the reservoir cap is secure after topping up.

⚠ Caution: Do not over tighten the reservoir cap. This can cause damage to the reservoir cap or the thread for the reservoir tank.

Brake Fluid Level

⚠ Warning: Do not drive the vehicle if the brake fluid level is below the minimum mark.

⚠ Caution: Make sure that the brake fluid does not contact the paint work during the topping up operation. Serious paint work damage can result. If a spillage does occur, immediately flush any brake fluid from the paint work with clean, fresh water and then wipe with a clean damp cloth.

The brake fluid level should read between the Min. and Max. marks.

1. Remove the reservoir cap. Top up to the Max. level.

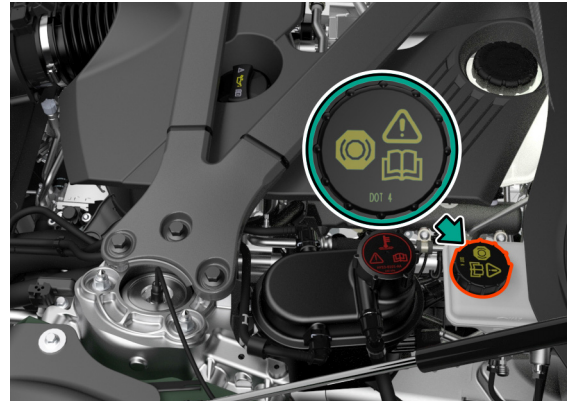

2. Install the reservoir cap securely.

Fluid Specifications

Fuel

Minimum 91 AKI unleaded fuel.

Recommended 93 AKI Super unleaded for optimum performance.

Use of fuel with more than 10% ethanol is not permitted.



Engine Oil

⚠ Caution: *To achieve the required high performance of synthetic lubricants, do not mix with mineral oils.*

A fully synthetic 0W-40 oil meeting the specifications detailed below can be used. No other viscosity grades or specifications are acceptable.

Authority	Standard
API	SN
ILSAC	GF5

Only use oils 'Certified For Gasoline Engines' by the American Petroleum Institute (API). An oil with this trademark symbol conforms to the current engine and emission system protection standards and fuel economy requirements of the International Lubricant Standardization and Approval Committee (ILSAC), comprised of U.S. and Japanese automobile manufacturers.



Engine Coolant

Contact your Aston Martin Dealer for information on engine coolant.

Brake Fluid

DOT 4

Air Conditioning Refrigerant

⚠ Caution: Refrigerant gas types must not be mixed. If you do, the air conditioning system can be damaged. If in doubt, consult your Aston Martin Dealer.

HFO-1234yf

Capacities

Fluid	Capacity
Fuel Tank	75 Litres 19.8 Gallons
Engine Oil (including filter)	8.5 Litres 8.9 Quarts
Engine Coolant (includes transmission cooling)	18.6 Litres 19.6 Quarts
Charge Cooler Coolant	6.7 Litres 7.0 Quarts
Automatic Gearbox (including cooler)	8.5 Litres 8.9 Quarts
Automatic Transmission Differential	1.1 Litres 1.1 Quarts
Screen Washer Reservoir	4.0 Litres 4.2 Quarts

Washers and Wipers**Windscreen Wash Fluid**

To refill the washer fluid, open the washer fluid reservoir cap and top up as required. In winter, to prevent the windscreen wash fluid freezing, increase the fluid concentration (refer to the manufacturers recommendations on the windscreen wash fluid container).

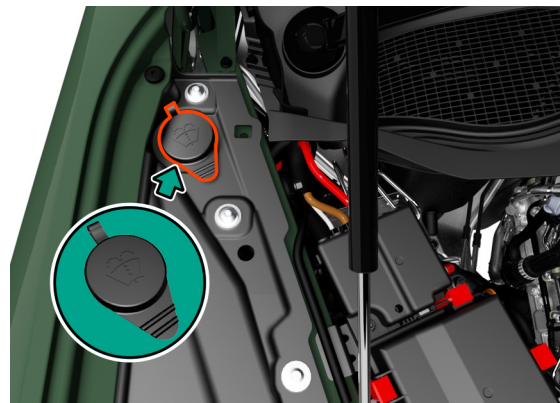

When the level of windscreen wash fluid is low an information message will show in the message centre and the amber warning symbol will come on.

Local or state regulations may restrict the use of volatile organic compounds (VOCs), which are commonly used as antifreeze agents in windscreen washer fluid. A windscreen washer fluid with limited VOC content should be used only if it provides adequate freeze resistance for all regions and climates in which the vehicle will be operated.

Wiper Blade Replacement

To remove a wiper blade, lift the wiper arm and press at point (B) to release the wiper blade.



Slide a new wiper blade on to the wiper arm until it locks into place.

Chassis Systems

Vehicle Body

Two door coupe with 2+2 seating.

Two door convertible with 2+2 seating.

- Extruded aluminium bonded monocoque body structure.
- Curlicue front and Aston Martin AeroBlade rear integrated aerodynamics.
- Deployable spoiler.

Steering

Electrically assisted, speed sensitive rack and pinion power steering. Column adjustment for reach and tilt.

Turns Lock to Lock

2.375 turns.

Turning Circle

12.4 m.
(40.7 ft).

Suspension

Front

Independent double aluminium wishbone incorporating anti-dive geometry. Coil over aluminium monotube dampers and anti-roll bar.

Rear

Multi-link suspension with coil over aluminium monotube dampers and anti-roll bar.

Brakes

Foot Brake

Cast Iron

	Front	Rear
Rotor Construction	Grooved and ventilated cast iron	Grooved and ventilated cast iron
Diameter	400 mm 15.7 inches	360 mm 14.1 inches
Calipers	Six Piston	Four Piston

Carbon Ceramic

	Front	Rear
Rotor Construction	Ventilated Carbon Ceramic	Ventilated Carbon Ceramic
Diameter	410mm 16.1 inches	360mm 14.1 inches
Calipers	Six Piston	Four Piston

Park Brake

Electrically operated independent park brake calipers on each rear brake rotor.

Chassis Features

- Three user selectable adaptive damping settings;
 - GT.
 - Sport.
 - Sport+.
- Anti-Lock Braking System (ABS).
- Hydraulic Brake Assist (HBA).
- Electronic Brake Force Distribution (EBD).
- Electronically controlled rear differential (E-Diff).

Wheels and Tires

Wheel and Tire Information

Summer tires

	Front	Rear
Wheel Size	9.5J x 21	11.5J x 21
Tire Size	275/35 ZR21 (Y)	325/30 ZR21 (Y)
Tire Pressure (up to 270 km/h / 167 mph)	2.3 Bar 34 Psi	2.3 Bar 34 Psi
Tire Pressure (above 270 km/h / 167 mph)	2.9 Bar 42 Psi	2.9 Bar 42 Psi

Tires installed to this vehicle shall have a maximum load rating not less than 875 kg (1929 lbs) front and 1000 kg (2205 lbs) rear, or a load index of 103 (front) and 108 (rear).

Winter tires

 V rated tires have a maximum speed of 240 km/h (149 mph).

	Front	Rear
Wheel Size	9.5J x 21	11.5J x 21
Tire Size	275/35 R21 (V)	315/30 R21 (V)
Tire Pressure	2.5 Bar	2.5 Bar
	36 Psi	36 Psi

Tires installed to this vehicle shall have a maximum load rating not less than 875 kg (1929 lbs) front and 925 kg (2039 lbs) rear, or a load index of 103 (front) and 105 (rear).

Wheel Bolt Torque

For wheel bolt torque (Refer to 'Wheel Bolt Torque', page 13.56).

Wheel Alignment

For the most up to date wheel alignment values, contact your Aston Martin dealer.

Tires

Tires of the correct type, manufacturer and dimensions, with correct cold inflation pressures are an integral part of every vehicle's design. Regular maintenance of tires contributes not only to safety, but to the designed function of the vehicle.

Road holding, steering and braking are especially vulnerable to incorrectly pressurized, badly installed or worn tires.

Tires of the correct size and type, but made by different manufacturers can have widely varying characteristics.

Tire Pressures

Make sure that correct tire pressures are carefully maintained. Road holding, steering, braking and tire wear are especially vulnerable to incorrect tire pressures.

Check tire pressures regularly and before starting any journey, and adjust accordingly.

Tire pressures increase slightly when the tires are hot. For an accurate reading, tire pressures should be checked when the tires are cold. After adjusting the tire pressures, make sure that the valve caps are securely replaced to provide an additional air seal and to prevent the ingress of dirt.

Tire Information

Damage

 Because of the high performance potential of this vehicle, Aston Martin strongly recommend replacement of any damaged or worn tire.

Tires should be examined at regular intervals for wear and damage. Inspect the tire treads and sidewalls for damage, i.e. bulges in the tread or the sidewalls, cracks in the tread groove and separation in the tread or the sidewalls. If damage is observed or suspected have the tire inspected by a tire professional.

Stones or other objects which have become lodged in the tire treads should be carefully removed.

Flat Spots

It is a characteristic of high performance tires that temporary 'flat spots' may develop if the vehicle is left standing in high or low ambient temperatures for any length of time.

These 'flat spots' will manifest themselves as minor vibrations when the vehicle is first driven from cold. As the tires warm up to operating temperature, normal tire shape should be restored and the vibrations cease. If vibrations persist, consult your Aston Martin Dealer.

Age

 Local regulations on tire life may apply.

Tires degrade over time, even when they are not being used. It is recommended that tires generally be replaced after six years of normal service. Heat caused by hot climates or frequent high loading conditions can accelerate the aging process.

New Tires

Each wheel and tire unit must be balanced dynamically and measured for Radial Force Variation (RFV) to make sure of efficient steering, optimum tire wear and maximum ride comfort. Because of the potentially high speeds, it is essential that wheel balancing is carried out when new tires are installed. Contact your Aston Martin Dealer for more information.

Running-In New Tires

When new tires have been installed, speed should be limited, particularly during the first 80 km (50 miles) or so of driving. Fast cornering, hard braking, and harsh acceleration should also be avoided during this period.

Tread Wear Marks

Tread wear marks (A) are incorporated into the construction of all tires. These marks are integral moulded ribs spaced at regular intervals around the circumference of the tire and extend across the full width of the tread, in all primary grooves.



When a tire has worn causing one or more of the marks to be flush with the outer face of the tread the tire has reached its wear limit. It then becomes illegal in certain countries and must be replaced.

Summer Tires

The recommended tires for this vehicle are asymmetrical and must be installed to the wheel with the tire mark 'OUTSIDE' on the outside of the wheel rim.

The tires are also of different sizes on the front and rear axles, therefore complete wheels cannot be swapped between axles.

Winter Tires

The tires installed as original equipment are designed with a rubber compound, tread pattern and width specially suited for high speeds in normal road conditions, but they are less suitable during extremes of low temperatures, snow and ice. The use of winter tires will considerably improve handling during these conditions. Only use Aston Martin approved winter tires - contact your Aston Martin Dealer for more information.

⚠ Warning: The maximum speed limit of the vehicle should be reduced when winter tires are installed. Winter tire speed limits and information should be provided upon installation. Please consult your Aston Martin Dealer for more information.

Winter tires must be installed to the correct winter wheels.

Winter tires must be used in vehicle sets, that is, installed on all four wheels. Do not exceed the tire speed rating when using winter tires.

Snow Traction Devices

⚠ Warning: The maximum speed when using snow traction devices is 48 km/h. Remove the snow traction devices immediately when the roads are clear of snow.

These are for temporary use when driving in heavy snow conditions. Snow traction devices should only be installed to the rear (driven) winter wheels. For more information regarding the correct snow traction device to fit to your vehicle, contact your Aston Martin Dealer.

US Department of Transportation

Uniform Tire Quality Grades

The following information relates to the tire grading system developed by the National Highway Traffic Safety Administration, which grades tires by tread wear, traction and temperature performance. All passenger vehicle tires must conform to federal safety requirements in addition to these grades.

Tread Wear

The treadwear grade is a comparative rating based on the wear rate of the tire when tested under controlled conditions on a specified government test course. For example, a tire graded 150 would wear one and one-half (1½) times as well on the government course as a tire graded 100. The relative performance of tires depends upon the actual conditions of their use, however, and may depart significantly from the norm due to variations in driving habits, service practices and differences in road characteristics and climate

Traction

⚠ Warning: The traction grade assigned to this tire is based on straight-ahead braking traction tests and does not include acceleration, cornering, hydroplaning, or peak traction characteristics.

The traction grades, from highest to lowest, are AA, A, B, and C. The grades represent the tire's ability to stop on wet pavement as measured under controlled conditions on specified government test surfaces of asphalt and concrete. A tire marked C may have poor traction performance.

Temperature

⚠ Warning: The temperature grade for this tire is established for a tire that is properly inflated and not overloaded. Excessive speed, underinflation, or excessive loading, either separately or in combination, can cause heat buildup and possible tire failure.

The temperature grades are A (the highest), B, and C, representing the tire's resistance to the generation of heat and its ability to dissipate heat when tested under controlled conditions on a specified indoor laboratory test wheel. Sustained high temperature can cause the material of the tire to degenerate and reduce tire life, and excessive temperature can lead to sudden tire failure. The grade C corresponds to a level of performance which all passenger car tires must meet under the Federal Motor Safety Standard No. 109. Grades B and A represent higher levels of performance on the laboratory test wheel than the minimum required by law.

Tire Sidewall Information

Both US and Canada Federal regulations require tire manufacturers to place standardized information on the sidewall of all tires. This information identifies and describes the fundamental characteristics of the tire and also provides a Tire Identification Number for safety standard certification and incase of a recall.

'P215/65R15 95H' is an example of a tire size, load index and speed rating. The definitions of these items are listed below.

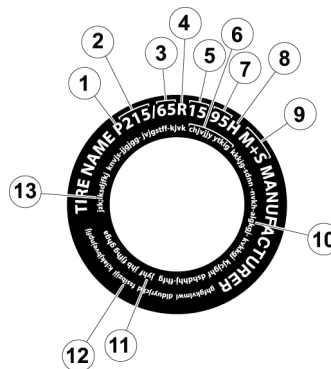

Information on 'P' Type Tires

 *The tire size, load index and speed rating for your vehicle may be different from this example.*

[1] P: A tire, designated by the Tire and Rim Association (T&RA), that may be used for service on cars, SUVs, minivans and light trucks.

 *If your tire size does not begin with a letter this may mean it is designated by either ETRTO (European Tire and Rim Technical Organization) or JATMA (Japan Tire Manufacturing Association).*

[2] 215: The nominal width of the tire in millimetres from side wall edge to side wall edge. In general, the larger the number, the wider the tire.

[3] 65: The aspect ratio which gives the tire's ratio of height to width.

[4] R: Shows a "radial" type tire.

[5] 15: The wheel or rim diameter in inches. If you change your wheel size, you will have to purchase new tires to match the new wheel diameter.

[6] TIRE IDENTIFICATION NUMBER (TIN): (Also known as 'DOT Code') The Tire Identification Number (TIN) begins with the letters 'DOT' and shows that the tire meets all federal standards. The next two numbers or letters are the plant code designating where it was manufactured, the next two are the tire size code and the last four numbers represent the week and year the tire was built. For example, the numbers 317 mean the 31st week of 1997. After 2000 the numbers go to four digits. For example, 2501 means the 25th week of 2001. The numbers in between are identification codes used for traceability. This information is used to contact customers if a tire defect requires a recall.

[7] 95: The tire's load index. It is an index that relates to how much weight a tire can carry.

 *You may not find this information on all tires because it is not required by federal law.*

[8] H: The tire's speed rating. The speed rating denotes the speed at which a tire is designed to be driven for extended periods of time under a standard condition of load and inflation pressure. The tires on your vehicle may operate at different conditions for load and inflation pressure. These speed ratings may need to be adjusted for the difference in conditions. The ratings range from 81-186 mph. These ratings are listed in the following chart.

Letter Rating	Speed Rating
M	81 mph
N	87 mph
Q	99 mph
R	106 mph
S	112 mph
T	118 mph
U	124 mph
H	130 mph
V	149 mph
W	168 mph
Y	186 mph

 For tires with a maximum speed capability over 149 mph, tire manufacturers sometimes use the letters ZR. For those with a maximum speed capability over 186 mph, tire manufacturers always use the letters ZR.

[9] TIRE TYPE:

- M+S or M/S
Mud and Snow
- AT
All Terrain
- AS
All Season.

[10] TIRE PLY COMPOSITION AND MATERIAL USED:

Shows the number of plies or the number of layers of rubber-coated fabric in the tire tread and sidewall. Tire manufacturers also must show the ply materials in the tire and the sidewall, which include steel, nylon, polyester, and others.

[11] MAXIMUM LOAD: Shows the maximum load in kilograms and pounds that can be carried by the tire. Refer to the Safety Compliance Certification Label, which is located on the B-Pillar or the edge of the driver's door, for the correct tire pressure for your vehicle.

[12] TREAD WEAR, TRACTION AND TEMPERATURE GRADES: (Refer to page 13.21).

[13] MAXIMUM PERMISSIBLE INFLATION PRESSURE: (Refer to page 13.27)

Vehicle Loading

⚠ Warning: Overloading the vehicle can negatively affect the handling and stopping performance of the vehicle tires.

Correctly loading this vehicle will provide maximum return of vehicle design performance. Before loading this vehicle, familiarize yourself with the following terms for determining the vehicle's weight ratings from the vehicle's Safety Compliance Certification Label.

Labels for US vehicles

MFD BY ASTON MARTIN LAGONDA LTD
WARWICKSHIRE, ENGLAND

MFD DATE

GVWR

GAWR F

R

THIS VEHICLE CONFORMS TO ALL APPLICABLE FEDERAL MOTOR VEHICLE SAFETY, BUMPER AND THEFT PREVENTION STANDARDS IN EFFECT ON THE DATE OF MANUFACTURE.

VEHICLE IDENT. No.

TYPE PC/VT

 **TIRE AND LOADING INFORMATION**

SEATING CAPACITY	TOTAL	FRONT	REAR

The combined weight of occupants and cargo should never exceed kg or lbs.

TIRE	SIZE	COLD TIRE PRESSURE
FRONT		<input type="text"/> kPa (<input type="text"/> PSI)
REAR		<input type="text"/> kPa (<input type="text"/> PSI)
SPARE		

SEE OWNER'S MANUAL FOR ADDITIONAL INFORMATION

Labels for Canadian Vehicles

MFD BY ASTON MARTIN LAGONDA LTD
WARWICKSHIRE, ENGLAND

THIS VEHICLE CONFORMS TO ALL APPLICABLE STANDARDS PRESCRIBED UNDER THE CANADIAN MOTOR VEHICLE SAFETY REGULATIONS IN EFFECT ON THE DATE OF MANUFACTURE.

CE VÉHICULE EST CONFORME À TOUTES LES NORMES QUI LUI SONT APPLICABLES EN VERTU DU RÈGLEMENT SUR LA SÉCURITÉ DES VÉHICULES AUTOMOBILES DU CANADA EN VIGUEUR À LA DATE DE SA FABRICATION.

MFD DATE

GVWR/PNBV

GAWR/PNBE F/AV
R/AR

VEHICLE IDENT. No.

TYPE PCVT

MFD Date: Month and Year the vehicle was manufactured (e.g. 08 / 16 = August 2016).

GVWR: Gross vehicle weight (curb weight + full payload).

GAWR F: Maximum load on the front axle.

GAWR R: Maximum load on the rear axle.

Seating Capacity: Shows the maximum number of passengers.

Payload: Make sure that the payload (cargo + passengers) does not exceed this limit.

Tire sizes: The size of tires to be used on this vehicle.

Cold inflation pressure: The maximum recommended tire inflation pressure.

Both labels are located on the vehicle door opening edge.

Payload: The payload is the combined weight of cargo and passengers that the vehicle is carrying. The maximum payload for your vehicle can be found on the Tire Label on the edge of the driver's door. Look for 'The Combined Weight of Occupants and Cargo Should Never Exceed XXX kg OR XXX lb' for maximum payload. The payload listed on the Tire Label is the maximum payload for the vehicle as built by the assembly plant. If any after market or Aston Martin Dealer installed equipment has been installed on the vehicle, the weight of the equipment must be subtracted from the payload listed on the Tire Label in order to determine the new payload.

Gross Vehicle Weight: The maximum recommended weight for a vehicle, including: the weight of the vehicle itself, fuel and other fluids, passengers, and all cargo.

TIRE AND LOADING INFORMATION
RENSEIGNEMENTS SUR LES PNEUS ET LE CHARGEMENT

SEATING CAPACITY NOMBRE DE PLACES	TOTAL TOTAL	FRONT AVANT	REAR ARRIERE
The combined weight of occupants and cargo should never exceed kg or lbs. Le poids total des occupants et du chargement ne doit jamais dépasser kg ou lbs.			
TIRE PNEU	SIZE DIMENSIONS	COLD TIRE PRESSURE PRESSION DES PNEUS A FROID	
FRONT AVANT		kPa (PSI)	
REAR ARRIERE		kPa (PSI)	
SPARE DE SECOURS		SEE OWNER'S MANUAL FOR ADDITIONAL INFORMATION VOIR LE MANUEL DE L'USAGER POUR PLUS DE RENSEIGNEMENTS	

 The illustrations shown are examples and may not accurately describe the labels on this vehicle.

Determining the Correct Load Limit

1. Locate the statement 'The combined weight of occupants and cargo should never exceed XXX kg or XXX lb' on the vehicle's tire label.
2. Determine the combined weight of the driver and passengers that will be riding in the vehicle.
3. Subtract the combined weight of the driver and passengers from XXX kg or XXX lb.
4. The resulting figure equals the available amount of cargo and luggage load capacity. For example, if the 'XXX' amount equals 1250 lb and there will be four 150 lb passengers in the vehicle, the amount of available cargo and luggage load capacity is 650lb (1250–600 (4x150) = 650 lb).
5. Determine the combined weight of luggage and cargo being loaded on the vehicle. That weight may not safely exceed the available cargo and luggage load capacity calculated in Step 4.

Maximum Permissible Inflation Pressure

The maximum permissible inflation pressure is the tire manufacturer's maximum permissible pressure and / or the pressure at which the maximum load can be carried by the tire. This pressure is normally higher than the manufacturer's recommended cold inflation pressure which can be found on the Safety Compliance Certification Label or Tire Label.

The cold inflation pressure should never be set lower than the recommended pressure on the Safety Compliance Certification Label or Tire Label.

 *The recommended cold inflation tire pressures for this vehicle can also be found in handbook .*

Safety Practices

⚠ Warning: *If your vehicle is stuck in snow, mud, sand, etc, do not rapidly spin the tires; spinning the tires can tear the tire and cause an explosion. A tire can explode in as little as three to five seconds.*

⚠ Warning: *Do not spin the wheels at over 35 mph. The tires may fail and injure a passenger or bystander.*

Driving habits have a great deal to do with your tire mileage and safety.

- Observe posted speed limits.
- Avoid fast starts, stops and turns.
- Avoid potholes and objects on the road.
- Do not run over curbs or hit the tire against a curb when parking.

Highway Hazards

No matter how carefully you drive there's always the possibility that you may eventually have a flat tire on the highway. Drive slowly to the closest safe area out of traffic. This may further damage the flat tire, but your safety is more important. If you feel a sudden vibration or ride disturbance while driving, or you suspect your tire or vehicle has been damaged, immediately reduce your speed. Drive with caution until you can safely pull off the road. Stop and inspect the tires for damage. If a tire is under-inflated or damaged, deflate it, remove the wheel and replace it with your spare tire and wheel. If you can not detect a cause, have the vehicle towed to the nearest repair facility or tire dealer to have the vehicle inspected.

Tire Terminology

Tire Label: A label showing the OE (Original Equipment) tire sizes, recommended inflation pressure and the maximum weight the vehicle can carry.

Tire Identification Number (TIN): A number on the sidewall of each tire providing information about the tire brand and manufacturing plant, tire size and date of manufacture. Also referred to as DOT code.

Inflation Pressure: A measure of the amount of air in a tire.

Standard Load: A class of P-metric or Metric tires designed to carry a maximum load at 35psi [37psi (2.5bar) for Metric tires]. Increasing the inflation pressure beyond this pressure will not increase the tire's load carrying capability.

Extra Load: A class of P-metric or Metric tires designed to carry a heavier maximum load at 41psi [43psi (2.9 bar) for Metric tires]. Increasing the inflation pressure beyond this pressure will not increase the tire's load carrying capability.

kPa: Kilo pascal, a metric unit of air pressure.

PSI: Pounds per square inch, a standard unit of air pressure.

Cold Inflation Pressure: The tire pressure when the vehicle has been stationary and out of direct sun light for an hour or more and prior to the vehicle being driven for 1 mile (1.6km).

Recommended Inflation Pressure: The cold inflation pressure found on the Safety Compliance Certification Label or Tire Label (found on the edge of the driver's door).

Bead Area of the Tire: Area of the tire next to the rim.

Sidewall of the Tire: Area between the bead area and the tread.

Tread Area of the Tire: Area of the perimeter of the tire that contacts the road when mounted on the vehicle.

Rim: The metal support (wheel) for a tire or a tire and tube assembly upon which the tire beads are seated.

Electrical Systems

Fuses

The electrical systems are protected by fuses. If any lamps, accessories, or controls do not function, inspect the applicable fuse.

If a fuse has blown, the inside element will be melted. If the same fuse blows again, avoid using that system and consult your Aston Martin Dealer as soon as possible.

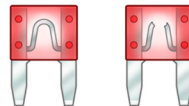

13.30 Maintenance and Technical Data

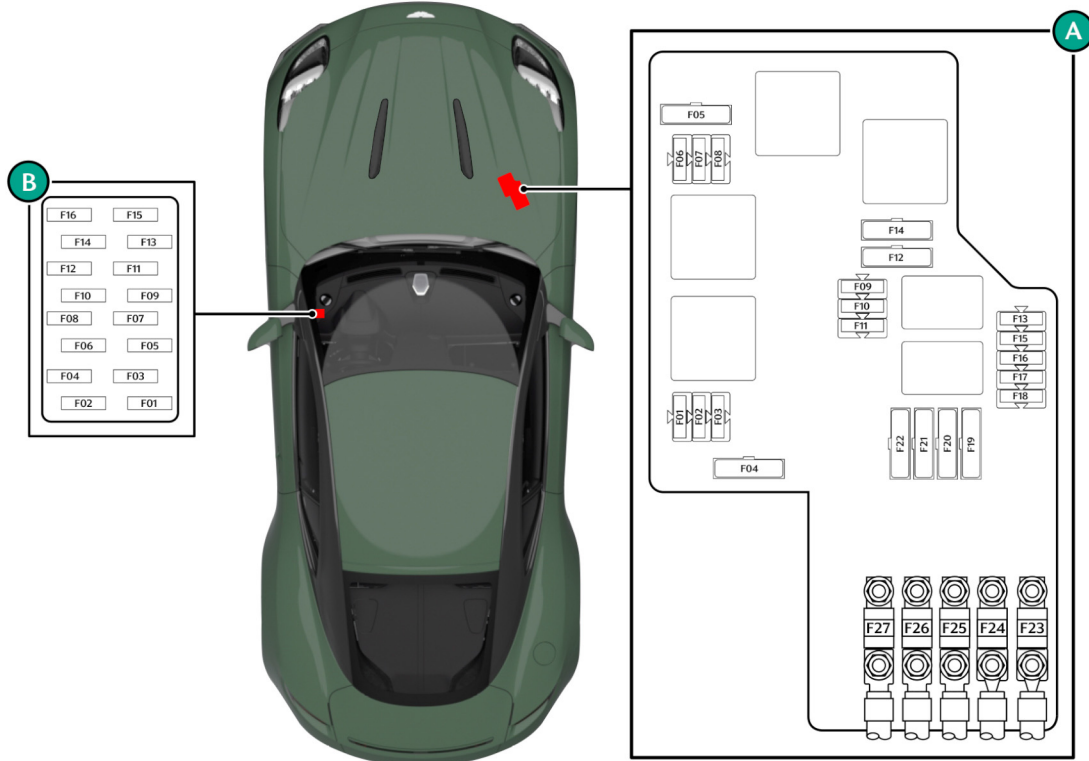

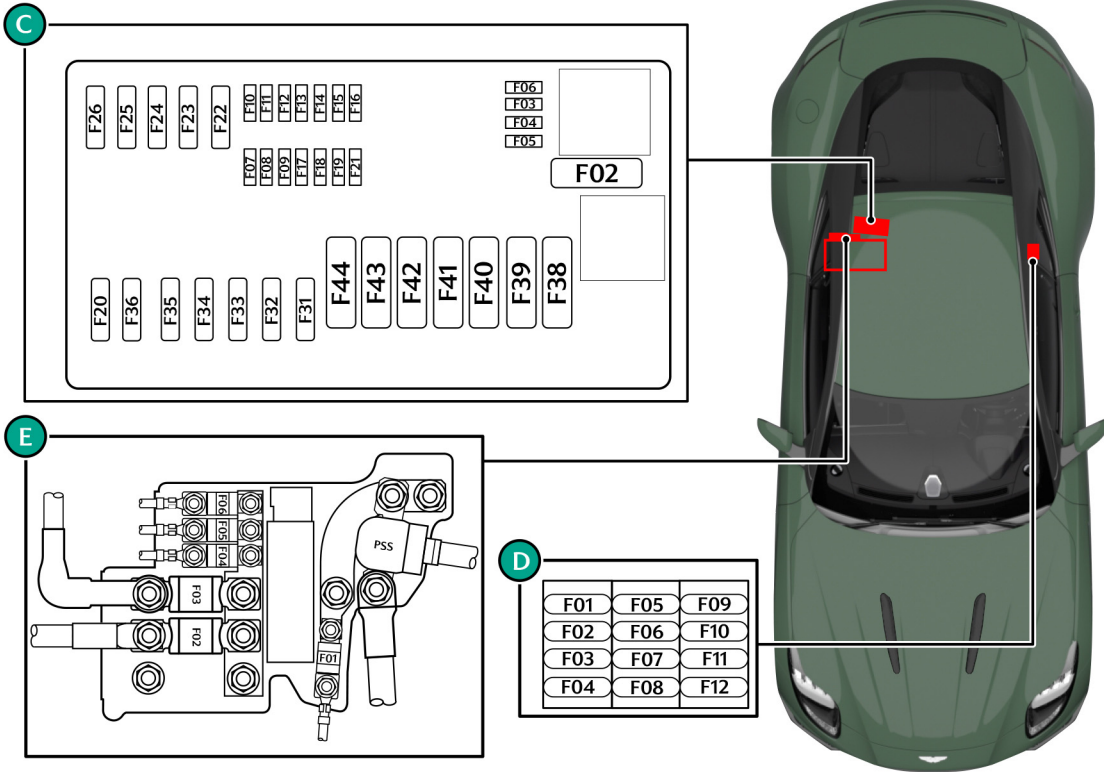

13.32 Maintenance and Technical Data

(A) Engine Bay Fuse Box

F1	15A	Exhaust Bypass Valves
F2	15A	Differential Cooling Pump
F3	15A	Coolant Pump
F4	20A	Coolant Pump
F5	15A	Engine Control Module (ECM) DMTL
F6	15A	ECM
F7	15A	ECM
F8	15A	ECM
F9	5A	Forward Radar
F10	5A	ECM
F11	5A	Brake Control Module
F12	10A	Front Body Control Module (BCM)
F13	15A	Horn
F14	30A	Starter Motor

F15	5A	-
F16	5A	-
F17	5A	-
F18	7.5A	-
F19	20A	Headlamps
F20	20A	Headlamps
F21	30A	Wipers
F22	30A	Wipers
F23	40A	Brake Control Module
F24	60A	Brake Control Module
F25	100A	Cooling Fan
F26	100A	Electronic Power Assisted Steering (EPAS)
F27	-	-

(B) Fascia Fuse Box

F1	7.5A	Ambient Light Module
F2	15A	HVAC Module
F3	10A	Centre Console Switch Pack
F4	7.5A	Instrument Cluster
F5	-	-
F6	7.5A	Steering Column Control Module (SCCM)
F7	20A	Drive Unit
F8	5A	-
F9	15A	SCCM
F10	10A	On Board Diagnostic (OBD) Socket
F11	5A	HVAC Control Panel
F12	7.5A	Wireless Phone Charger
F13	7.5A	Infotainment Display Screen
F14	15A	Common Powertrain Control (CPC) Module
F15	20A	Steering Column Lock
F16	7.5A	Wireless Phone Charger

(C) Rear Cabin Fuse Box

F2	30A	Heated Rear Window
F3	15A	Front 12V Socket
F4	15A	-
F5	15A	-
F6	5A	-
F7	5A	-
F8	5A	Tire Pressure Monitoring System
F9	5A	Connected Car Module
F10	5A	E-Diff
F11	5A	Rain Light Sensor
F12	7.5A	Park Distance Control
F13	7.5A	USB Panel
F14	7.5A	Occupant Restraint Control (ORC) Module
F15	10A	Seat Modules
F16	10A	-
F17	15A	Infotainment Module
F18	15A	Left Seat Adjust
F19	15A	Right Seat Adjust
F20	20A	Active Aero
F21	15A	Transmission Control module (TCM)
F22	30A	Fuel Pump Control Module

13.34 Maintenance and Technical Data

F23	25A	-
F24	25A	Adaptive Damping Module
F25	25A	Driver Seat Control module
F26	25A	Passenger Seat Control module
F31	30A	Convertible Roof
F32	30A	Door Module
F33	30A	Door Module
F34	30A	Convertible Module
F35	30A	E-diff
F36	30A	Convertible Module
F38	40A	Front Body Control Module (BCM)
F39	40A	Rear BCM
F40	40A	Rear BCM
F41	40A	Audio Amplifier
F42	40A	Convertible Roof Module
F43	40A	HVAC Blower
F44	40A	Front BCM

(D) Auxiliary Cabin Fuse Box

F1	10A	Trickle Charger
F2	10A	Electronic Ignition Switch (EIS)
F3	5A	Connected Car Module
F4	10A	Alarm
F5	10A	Presenting Handles Module
F6	7.5A	Instrument Cluster
F7	5A	Decklid Latch
F8	5A	ECM
F9	-	-
F10	30A	Audio Amplifier
F11	30A	Audio Amplifier
F12	-	-

(E) Battery Fuses

PSS		Pyrotechnic Safety Switch
F1	40A	Keep Awake
F2	250A	Engine Fuse Box
F3	200A	Rear Fuse Box
F4	60A	-
F5	60A	-
F6	60A	Fascia Fuse Box

Pyrotechnic Safety Switch

The Pyrotechnic Safety Switch (PSS) is designed to operate in both over-current and crash events. When activated, the PSS will completely isolate the electrical system from the battery to reduce the risk of electric shock or a vehicle fire.

The PSS is a single-use item and will require replacement if it has been activated.

Battery**Battery Warnings**

⚠ Warning: Do not allow flames, sparks or lighted substances to come near the battery. Batteries normally produce explosive gases when charged or when jump started. When working near the battery, always make sure that neither you nor the battery is electrostatically charged. Always have sufficient ventilation.

⚠ Warning: Never place metal objects on the battery or allow the positive terminal of the battery to contact parts of the vehicle body. This can create a spark or a short circuit which can ignite gases created when the battery is charged.

⚠ Warning: When lifting a plastic cased battery, excessive pressure on the end walls could cause acid to flow through the vent caps, resulting in personal injury, damage to the vehicle or battery. Lift the battery with a battery carrier or with your hands on opposite corners.

⚠ Warning: Keep batteries out of reach of children.

⚠ Warning: Batteries contain sulphuric acid. Avoid contact with skin, eyes or clothing. Shield your eyes when working near the battery to protect against possible splashing of acid solution. In case of acid contact with skin or eyes, flush immediately with water for a minimum of 15 minutes and get prompt medical attention. If acid is swallowed, get medical help immediately.

⚠ Caution: The engine must never be run with the vehicle battery disconnected. This can cause damage to vehicle electrical modules.

⚠ Caution: Apart from vehicle recovery, this vehicle must not be driven if the vehicle battery is incapable of starting the engine. In this case the vehicle battery must be replaced. Contact your Aston Martin Dealer.

⚠ Warning: Battery posts, terminals and related accessories contain lead and lead compounds. Wash hands after handling.



⚠ DANGER/POISON			
 SHIELD EYES EXPLOSIVE GASES CAN CAUSE BLINDNESS OR INJURY	 NO • SPARKS • FLAMES • SMOKING	 SULFURIC ACID CAN CAUSE BLINDNESS OR SEVERE BURNS	FLUSH EYES IMMEDIATELY WITH WATER GET MEDICAL HELP FAST 
KEEP OUT OF THE REACH OF CHILDREN DO NOT TIP: KEEP VENT CAPS TIGHT AND LEVEL			

Vehicle Battery: Banner 92AH

The vehicle battery is maintenance free and should only require checking by your Aston Martin Dealer during regular vehicle services. To access the vehicle battery remove the trim panel, located in the right rear environment.

Battery Level Protection

⚠ Caution: If the battery is not capable of starting the engine, replace the battery as soon as possible.

Using vehicle electrical systems such as the infotainment system, with the ignition on, but the engine off, will drain the battery charge.

To prevent battery voltage falling below the level required to start the vehicle, the vehicle's battery monitoring system will shut down non-essential electrical systems before this happens.

After approximately 2 to 10 minutes (dependent on the rate of battery charge drain) a message is shown in the infotainment display.

If a low battery warning message shows, start the engine and let it idle so the battery can recharge¹, or connect a suitable battery charger or conditioner.

Vehicle Battery Disposal

The incorrect disposal of a vehicle battery can be extremely hazardous to health and the environment. Most batteries contain materials that, when disposed of incorrectly, may leak into the environment. This can contribute to soil and water pollution and endanger wildlife.

Do not dispose of a battery in fire or water.

Follow your local authorized standards for disposal. Call your local authorized recycling centre to find out more about recycling automotive batteries. Do not dispose of your vehicle battery in the household waste.



¹ If driving the vehicle to recharge the battery, a journey distance of approximately 30 miles or 48 km will be sufficient to recharge the battery.

Battery Conditioner

(Optional)

⚠ Caution: Do not attempt to start the vehicle with a battery conditioner connected to the mains supply.

The Aston Martin battery conditioner is suitable for use on all types of 12 volt AGM and lead acid batteries.

If this vehicle is not going to be used for a period of time, and mains power is available, use a battery conditioner to maintain the battery charge level. When connected the battery conditioner will maintain a small trickle charge to keep the battery in a fully charged state. A battery conditioner is designed for conditioning of partially or fully charged batteries. It will not effectively charge a discharged battery.

The battery conditioner uses a magnetic disc to attach to the charger socket (A). To connect the battery conditioner, open the deck lid and attach the charger plug onto the charger socket. The deck lid can then be closed and locked with the charger connected.



 For further safety information and operating instructions, refer to the instructions supplied with the battery conditioner.

Lamps

External Lamps

All external lamps use LEDs and are contained in a sealed lamp units.

The lamp units are not repairable. If a lamp or lamp unit fails contact your Aston Martin Dealer.

Internal Lamps

All internal lamps are LEDs and are not repairable.

If an LED lamp fails contact your Aston Martin Dealer.

Vehicle Care

Washing

⚠ Warning: Washing and polishing agents containing silicone should not be applied to glass. This will reduce the efficiency of the windscreen wipers, causing smears which will reduce visibility, particularly during darkness and in the rain.

⚠ Caution: Commercially operated automatic vehicle washes, jet washes and power operated mops are not recommended. The detergents used can contain certain chemicals which may, over time, be detrimental to some exterior parts of the vehicle. Prolonged usage of automatic vehicle washes and power operated mops will also cause fine scratches in the paint surface.

Aston Martin are able to supply a range of products to clean and protect your vehicle. Contact you Aston Martin Dealer for further information.

During the winter months, it is advisable to wash the vehicle more frequently, paying particular attention to the underside to combat the detrimental effects of any salt and sand contamination picked up from treated roads.

To delay the onset of corrosion developing on the brake components, Aston Martin recommend that after washing this vehicle, the vehicle should be driven a short distance to make sure that all water and cleaning products have dried off.

For best results:

- Do not wash the vehicle in strong sunlight. Let the vehicle cool before washing.
- Do not use household soaps or detergents.
- Do not direct water hoses at full force around the door and trunk lid seals.
- Do not use a brush on the car body as this will leave little scratches.

Suggested washing method:

1. Fill two buckets with water. Add a mild neutral detergent, as directed by the detergent manufacturer to one of the buckets.
2. Use a hose to remove all dust and mud residue from the vehicle. Don't use a strong jet, as this can rub grit over the paint and scratch it.
3. Soak a large clean wash mitt or a soft clean sponge in the soapy water, and begin applying it to the vehicle. Wash the vehicle section by section, starting at the top. Circle around the car several times, washing lower areas with each round. Rinse the dirt out of the wash mitt or soft sponge in the bucket with plain water frequently.
4. After one section is washed, rinse it with the hose before moving on, don't let the soap dry on the paint as this can stain it. Always keep the vehicle wet, this will prevent droplets from drying on the paint and leaving water-spots.
5. Dry the car with a chamois leather before it air-dries.

Paint Work

Modern water based paints are much safer and more environmentally friendly than solvent based paints. Water based paints are however more susceptible to contamination and marking by corrosive substances. The following list is not exhaustive but does show the most common contaminants which may adversely affect your paint work:

- Bird droppings,
- Antifreeze,
- Tree sap,
- Oils and greases,
- Insect remains.

Wash such substances from the vehicle using clean warm water with vehicle shampoo at the earliest opportunity, especially in sunny weather which can accelerate contamination.

 *Other groups of contaminants may be added to this list as experience of water based paints and finishes increases.*

Satin Paint

(Optional)

 ***The Aston Martin new car warranty covers defects in materials or workmanship of the paint work. The warranty does NOT cover repairs to your satin or matt paint work caused by negligence, lack of or improper maintenance such as waxing or polishing the finish, environmental influences, or improper repairs or damage that causes the satin finish to become glossy.***

In comparison to conventional paints with a gloss or metallic surface, satin paint work must be cared for slightly differently. In order to avoid damage to the satin paint work, make sure that the cleaning and care points below are followed:

1. Only use cleaning products recommended by Aston Martin. Abrasive cleaning products will change the satin appearance of the paint and must not be used.
2. Do not polish or wax the paintwork. This can lead to glossing of the paintwork.
3. Do not wash the car in an automatic car wash. This will avoid particles such as sand and dust, from damaging the painted surface.
4. Only use a soft sponge to clean the vehicle. Do not use abrasive cleaning tools.
5. Remove insect remains, bird droppings, resins, tar spots, fuels and oil immediately. Avoid strong rubbing while cleaning the vehicle.
6. Any stickers applied to the paint work will leave a mark when removed.
7. Repairs to the paint work must be completed by an Aston Martin category A or B body shop.

Front Grille

Wash and clean the vehicle's front grille in the same way as the paint work, but make sure that the front grille is dried off completely leaving no water droplets on the grille (wipe the front grille last using a chamois leather): Chrome polish or other abrasive cleaners must not be used.

Ceramic Brake Rotors

(Optional)

To avoid possible damage to the ceramic brake rotors, when washing the road wheels with products or materials other than a mild soapy water solution always remove the wheels from the vehicle.

Road Wheels

To avoid possible damage to the alloy road wheels, wheel nuts and wheel centre trims, from a build up of brake dust wash and clean the alloy road wheels frequently, using a mild soapy water solution only. Do not use chemical alloy road wheel cleaners, as they can often have a high acid or alkaline content and could cause discolouration. Always clean one wheel at a time and do not allow the cleaning solution to dry on the wheel. Fully flush off with clean water.

Headlamp Lenses

Only use a mild soapy water solution when washing the headlamp lenses. Do not use cleaning materials which contain solvents.

Cleaning materials which contain solvents, i.e. tar remover, petrol, waxes or polishes, may damage the headlamp lens.

Under Hood Cleaning

Under hood cleaning using high pressure hoses or steam cleaners should not be carried out. The electronic control module connections and fuse boxes can be damaged by indiscriminate use of high pressure cleaning equipment.

Polishing

Approximately twice a year, a good quality polish should be applied to the body work and then buffed, using a soft lint free cloth.

The alloy wheel rims should be treated with a cleaner which is specifically manufactured for this purpose.

Bodywork Maintenance

Check the drain holes in the bottom face of each door periodically and clear if necessary.

Upholstery, Trim, Carpets and Seats

⚠ Warning: Fumes from cleaning solvents may be dangerous in confined spaces. Make sure that the vehicle is well ventilated and follow the manufacturer's printed instructions when using these products.

⚠ Caution: Certain types of clothing, such as denim and vegetable tanned leather, are prone to 'dye transfer'. This can cause discolouration in the leather. Make sure that the affected areas are cleaned and re-protected as soon as possible.

The seats and soft trimmed components of this vehicle are covered in natural leather hide. In general, this natural leather upholstery requires little attention. The seats should be brushed with a soft brush from time to time and may be cleaned occasionally with a cloth damped in soap and water.

Do not use detergents, alcohol based cleaners, quick cleansers or furniture polishes. These products may initially give an impressive result, but their use will lead to rapid deterioration of the leather and will invalidate the warranty.

Several times a year, a leather conditioner or preservative should be used. Appropriate care materials are obtainable from your Aston Martin Dealer.

The brushed and anodised aluminium trim should be cleaned using a dry clean lint free cloth.

Alcantara®¹ roof linings and other soft trimmed areas may be brushed with a soft brush. Stains from water based substances such as coffee, tea or soft drinks should be cleaned as soon as possible with mild soap and water.

Consult your Aston Martin Dealer for instructions on the removal of more difficult stains such as oil, grease or ballpoint ink.

Carpets should be cleaned regularly with a vacuum cleaner. Any stains or grease marks should be removed with a good quality solvent suitable for use on carpets.

Care and Maintenance of Seat Belts

⚠ Caution: Do not allow seat belts to be retracted until they are completely dry.

To make sure that the restraint webbings are in correct working order, regularly check the seat belts. Look for fraying, cuts, burns and similar problems. Make sure that the latches and buckles operate correctly. If a seat belt is not in good condition or is not working correctly, consult your Aston Martin Dealer.

Any seat belt that has been worn during a serious collision should be replaced by an Aston Martin Dealer.

To clean the seat belts, use mild soap and water; do not use bleach, solvents or dyes, as they can weaken the material. Allow the seat belts to dry thoroughly before use.

¹ Alcantara is the registered trademark of Alcantara SPA, Italy and used with permission

Convertible Roof Cleaning

⚠ Caution: Do not leave the roof in the lowered (folded) position for extended periods of vehicle storage. Permanent damage to the convertible roof fabric may occur including soiling and fading along folds.

⚠ Caution: Do not use automatic vehicle washes. Brushes, detergents and pressurized water jets may damage the roof fabric. Do not use power washers. Jets of water may damage the weather seals and the roof fabric. Do not use spot cleaners, chemical diluents or any organic cleaners. If in doubt, contact your Aston Martin Dealer.

To maintain the appearance and condition of the roof fabric the cleaning recommendations given below should be followed. This is of particular importance in the case of light coloured roof fabrics.

Always remove bird droppings as soon as possible. The organic acids in bird lime can adversely affect the roof fabric.

Carefully vacuum clean the roof fabric to remove any loose particles. Gently, and evenly, wash the roof fabric using a mild soap solution and a soft brush.

 *A hard brush will damage the fabric fibres.*

Rinse the roof fabric thoroughly with clean water to remove any traces of soap. Allow the roof fabric to completely dry before operating the roof.

Powertrain Specifications

4.0L V8 Engine

All alloy 32 valve V8 engine featuring:

- Dual twin-scroll turbochargers.
- Independent quad-variable camshaft timing.
- Engine stop/start.
- Twin water-to-air charge air coolers.

Engine Capacity

3982 cc (242 CID).

83 mm (3.26 inch) Bore.

92 mm (3.62 inch) Stroke.

Compression Ratio

8.6:1.

Firing Order

1 - 5 - 4 - 2 - 6 - 3 - 7 - 8.

Fuel delivery

Multi-point sequential fuel injection.

Idle Speed

800 rpm.

Ignition

'Coil on Plug' ignition system.

Lubrication

Wet sump pressurized system.

Emission Controls

Four oxygen sensors (two per bank) with four catalytic converters (two per bank).

Evaporative loss purge system.

Transmission

- Rear mounted ZF 8HP75 eight-speed automatic gearbox.
- Lateral transmission dampers.
- Cast aluminium torque tube with carbon fibre drive shaft.
- Electronically controlled locking differential with integrated coolant jacket.
- Front mounted transmission radiator with transmission mounted heat exchanger and pump.

Gear Ratios

1st	4.714
2nd	3.143
3rd	2.106
4th	1.667
5th	1.285
6th	1.000
7th	0.839
8th	0.667
Reverse	3.317
Final	3.083

Performance

Parameter	Value
Maximum Power / Engine Speed	680 PS 670 Bhp 500 kW at 6000 rpm
Maximum Engine Speed	7200 rpm
Maximum Torque / Engine Speed	800 Nm (590 lb.ft) between 2800 rpm and 5500 rpm
Maximum Speed (Where Permitted)	325 km/h (202 mph)
0-100 km/h (0-62 mph)	Coupe: 3.6 Seconds Volante: 3.7 Seconds

Dimensions

Interior Dimensions	
Front	
Effective Headroom	980 mm (38.5 Inches)
Effective Leg-room	1145 mm (45 Inches)
Effective Shoulder-room	1380 mm (54 Inches)
Rear	
Effective Headroom	635 mm (25 Inches)
Couple Distance ₁	635 mm (25 Inches)
Effective Shoulder-room	1235 mm (48.5 Inches)

₁. The couple distance is the distance between the hip point for the rear occupant and the hip point for the front seat occupant.

Vehicle Weights	Coupe	Volante
Unladen Mass	1820 kg (4010 lbs)	1930 kg (4255 lbs)
Gross Vehicle Weight (GVW)	2260 kg (4980 lbs)	2360 kg (5200 lbs)
Luggage Compartment Volume	280 Litres (10 Cu ft)	
Luggage Compartment Load	40 kg (90 Lbs) ₁	
Towing Capacity	Not Applicable ₂	

₁. Maximum load, Evenly Distributed

₂. This vehicle is not engineered to tow any form of caravan, boat or trailer. No towing devices are approved to install to this vehicle, other than a front towing eye to aid recovery of loading of this vehicle onto a transporter.

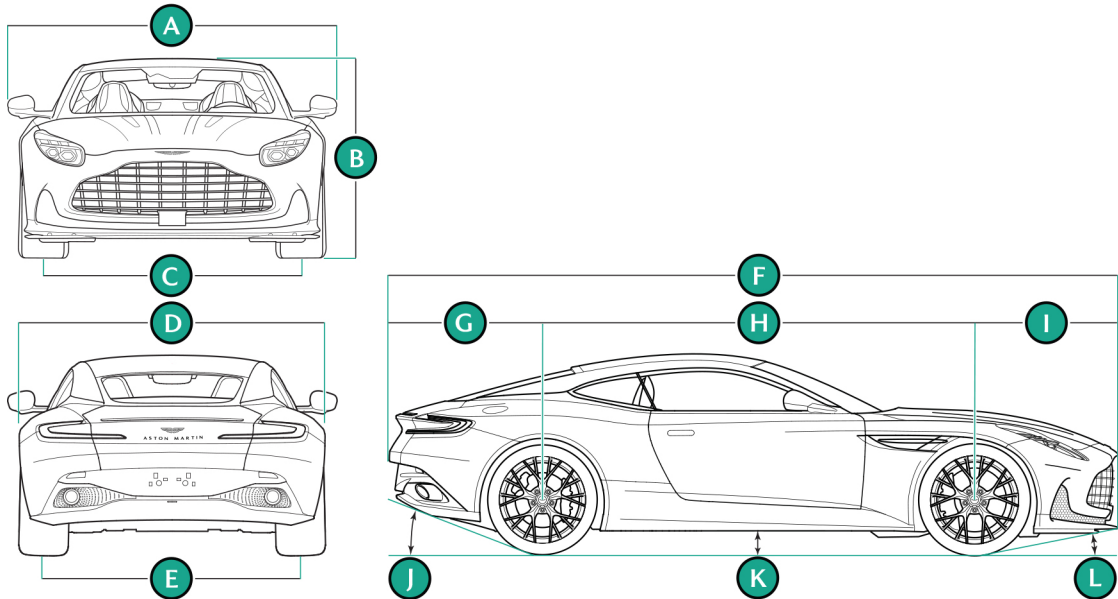
External Dimensions***Coupe***

Volante

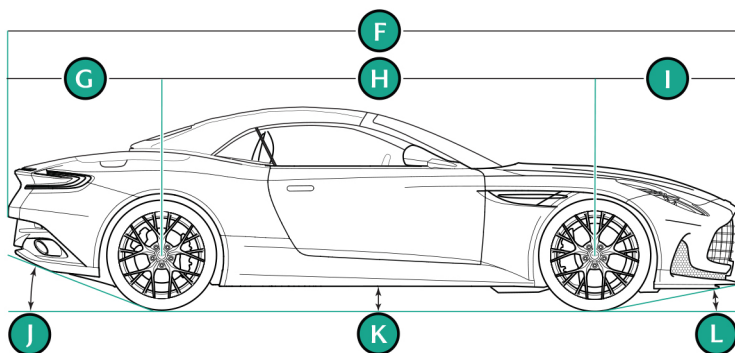
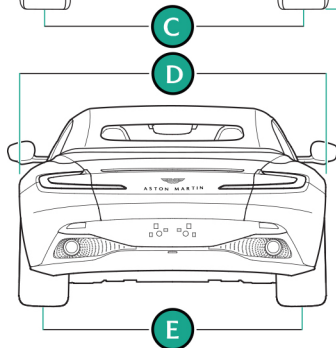
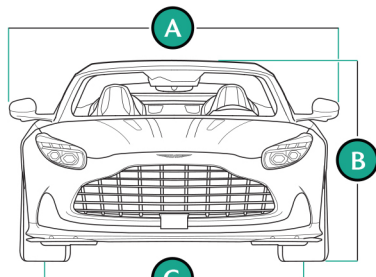

Emergency and Breakdown

External Dimensions

		Coupe	Volante
A	Width (with mirrors)	2135 mm	
B	Height	1295 mm	1305 mm
C	Front track	1665 mm	
D	Width (without mirrors)	1980 mm	
E	Rear track	1650 mm	
F	Overall length	4725 mm	
G	Rear overhang	995 mm	
H	Wheelbase	2805 mm	
I	Front overhang	925 mm	
J	Departure angle	20.5°	
K	Ground clearance	120 mm	
L	Approach angle	10.1° ₁	

1. 10.0° if black or carbon fibre lower body package is installed.

Vehicle Recovery

⚠ Caution: *When the vehicle is moved by transporter make sure that the vehicle is not strapped down by the suspension control arms.*

⚠ Caution: *Power braking and power steering are not available with the engine off. Substantially higher brake pedal pressures and steering effort are required.*

⚠ Caution: *If there is a transmission fault, this vehicle must be transported.*

If the park brake was applied and the vehicle has lost power, the park brake will not release. Call Aston Martin Assistance or your local Aston Martin Dealer.

Your vehicle should always be recovered on a vehicle transporter₁ and should only be towed for **short distances**, for example, if it is causing an obstruction or if it requires winching onto a transporter.

₁ The recommended method for a recovering vehicle is to have it transported in a purpose built, covered, vehicle transporter.

If moving the vehicle in such a situation:

1. Insert the tow eye carefully through the grill and install to the exposed female threads (A) until fully engaged against the vehicle body.

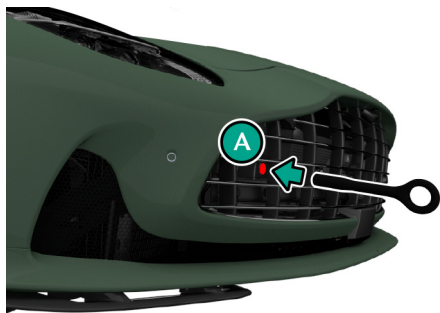



 *The tow eye has a left hand thread.*

 *Protect vehicle paint work when installing the tow eye.*

2. When being towed, use the footbrake very gently when required, to prevent excessive slack in the tow rope.

Jump Start From Another Vehicle

 **Warning:** *The donor vehicle must have a 12 volt battery and a negative (-) earth terminal to make sure that the correct battery polarity is maintained.*

 **Caution:** *Apart from vehicle recovery, this vehicle must not be driven if the vehicle battery is incapable of starting the engine. In this case the vehicle battery must be replaced.*

 **Caution:** *If the voltage or earth of the donor vehicle is different or not known, do not attempt starting in the way described.*

If this vehicle will not start due to a discharged battery, it may be started, **for vehicle recovery**, by connecting the battery from another vehicle (donor) to this vehicle (recipient).

Jump Start Procedure

⚠ Caution: Remove rings, metal watch bands and any other jewellery.

⚠ Caution: Set all electrical motors and ancillaries in both vehicles to off.

⚠ Caution: Set all lamps to off except those needed to protect vehicles or illuminate the work area.

 Recharge time will depend on the initial 'state of health' of the discharged battery.

 If the vehicle still will not start, contact your Aston Martin Dealer.

1. Position the donor vehicle so that the connecting cables will reach into the recipient engine bay. Apply the park brake and leave the engine running.
2. Access the jump start terminal in the recipient engine bay.
3. Slide the cover for main power fuse bank (1) off to access the jump start point.

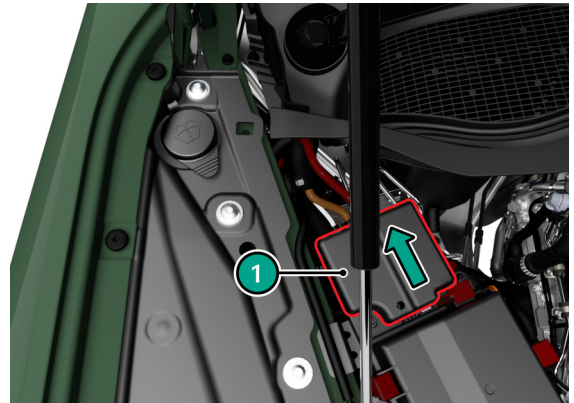

4. Identify the positive (2) and negative (3) jump start points shown.

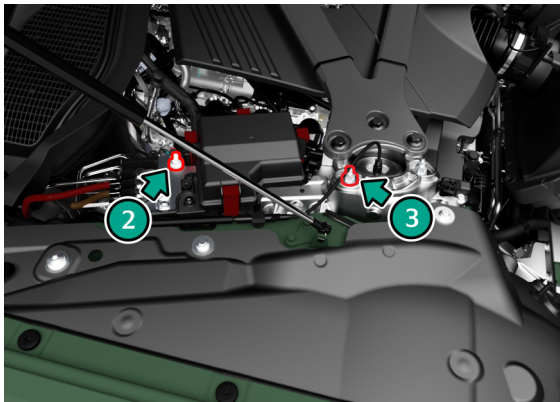

5. Connect the positive cable (4) between the positive terminal of the donor battery and the positive (+) jump point (2) on the main power feed.
6. Connect the negative cable (5) between the negative terminal of the donor battery and the suspension earth (-) nut (3).

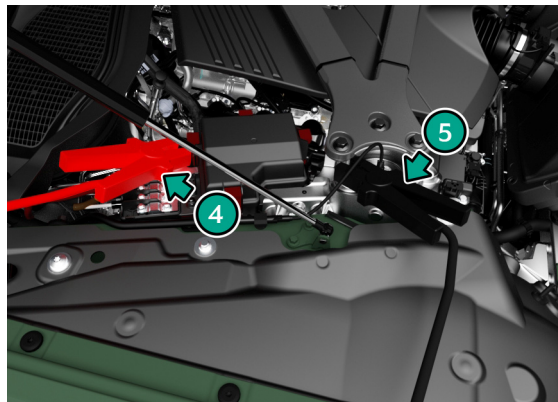

7. Start the donor vehicle engine and increase the engine speed and run at about 1500 – 2000 rpm for two minutes₁.

₁ Charge time can depend on the battery state of the donor vehicle.

 *The donor vehicle must be set to off. If the donor vehicle is not set to off the recipient vehicle will not start.*

8. Set the donor vehicle to off.
9. Start the engine of the recipient vehicle.
10. Leave the jump start cables attached and the engines running for 2 to 3 minutes to allow the battery to charge.
11. Remove the jump start cables, first the negative cable from both vehicles and then the positive cable from both vehicles.

Allow the recipient engine to run until the discharged battery is sufficiently charged (15 to 20 minutes) to start the engine without assistance. Set the engine to off and restart the engine. Take the vehicle on a long run to fully charge the battery.

Contact your Aston Martin Dealer to have the battery checked or replaced.

Vehicle Lifting

 **Warning: Make sure that no persons are in the vehicle before the vehicle is lifted.**

 **Warning: Make sure that the park brake is applied and that the vehicle transmission is in P (Park).**

 **Warning: Make sure that the vehicle is parked on firm and level ground to give a secure base for the jack.**

 **Warning: Do not lift the vehicle by placing a jack or other lifting equipment under the suspension arms.**

 **Warning: Do not use a jack or other lifting equipment further inboard on the vehicle than the jacking points shown.**

If this vehicle is to be raised using a vehicle jack make sure that the following jacking points are used.

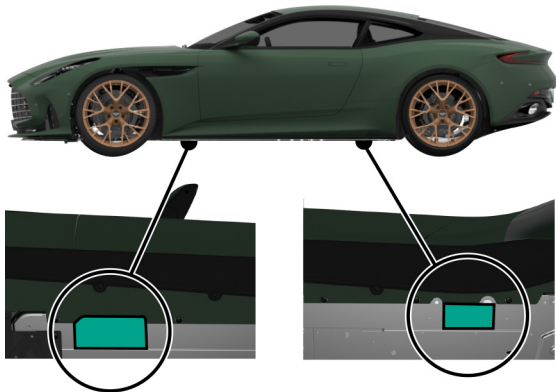

Wheel Bolt Torque

⚠ Caution: You must use an applicable plastic-sleeved socket to remove, install, and tighten the wheel bolts. This will help to prevent damage to the surface of the wheel.

All wheel bolts must be tightened in two stages:

- Tighten every second wheel bolt (in the order shown) to 70 Nm (52 lb/ft) until all five bolts are tightened.

 If a locking wheel bolt is installed, this should be installed last.

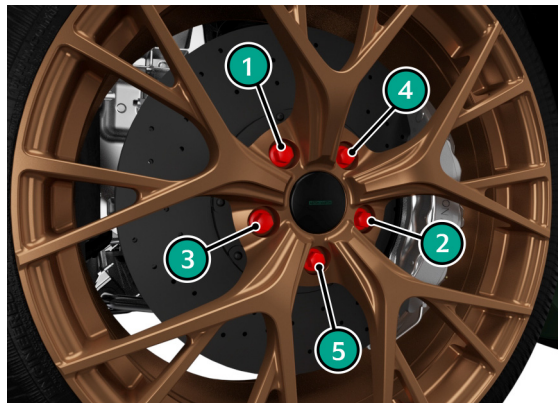

- Tighten every second wheel bolt (in the order shown) to 150 Nm (111 lb/ft) until all five bolts are tightened.

Tire Repair Kit

⚠ Warning: Do not use the system to seal a tire that was damaged while driving with insufficient air pressure (e.g. tire cuts, cracks, bumps or similar damage). Do not use the system to seal tires with side wall damage. Only punctures in the tread area of tires may be sealed.

⚠ Warning: Do not stand directly beside the tire while the compressor is pumping. Watch the side wall of the tire. If there are any cracks, bumps or similar damage set the compressor to off. The journey should not be continued. Contact your nearest Aston Martin Dealer.

⚠ Warning: If a tire pressure of 1.8 bar (26 Psi) cannot be reached then the tire can not be sealed. Do not attempt to re-inflate the tire. Contact your Aston Martin Dealer.

⚠ Warning: If the pressure in the tire after driving for 3 km is below 1.3 bar (19 Psi) the tire has not been effectively sealed. The journey should not be continued. Contact your nearest Aston Martin Dealer.

⚠ Warning: After a longer period of rest, the tire pressure should be rechecked.

⚠ Caution: The tire sealant kit only provides temporary mobility. Always refer to local laws and regulations on the use and repair of tires that have been treated with any form of temporary mobility aid. Consult a tire specialist for advice.

 Inform the tire specialist that the tire contains sealant.

 Remains of liquid sealant must be handed over to your dealer or disposed of in compliance with local waste disposal regulations. Dispose of empty sealant bottles together with normal household waste.

Operation

Remove the tire sealant kit from its location in the trunk. Follow the instructions detailed on the lid.

Read the following instructions and warnings carefully before using the tire sealant kit. Compliance with these instructions is vital to make sure of vehicle and user safety. Non-compliance with these instructions means risking severe tire damage and hazardous vehicle behaviour which can lead to a road accident involving damage to property or injury to persons.

 *It will be necessary to use two canisters (supplied) to repair a tire on this vehicle.*

- Make sure that the vehicle is parked far enough from traffic so that there is no danger from passing vehicles and so that you do not disrupt the traffic.
- A maximum speed of 80 km/h (50 mph) may not be exceeded at any time after sealing the tire with the system.
- The system provides only a **temporary emergency repair** for continuing the journey up to 200 km (125 miles) or to the nearest Aston Martin Dealer.

- If the nearest Aston Martin Dealer is over 200 km (125 miles) away, contact your Aston Martin Dealer.
- The system will effectively seal a tire that was punctured by an object with a diameter of up to 6 mm. It is possible that a tire, especially with greater damage, will not be sealed. Do not remove objects that punctured the tire if they are still lodged in the tire.
- The sealant bottle needs to be exchanged before it expires. **Do not** use the system after the expiry date on the sealant bottle or casing has been reached. Contact your nearest Aston Martin Dealer.
- Do not attempt to inflate other objects without using a system adapter and do not inflate objects with a volume greater than 50 litre (air mattresses, rubber boats, etc.). Do not let the system pump air for more than 10 minutes without stopping it and allowing it to cool down.

Both the hose and the bottle of sealant need to be replaced after using the system. Sealant deposits in a used hose may cause the system to operate incorrectly. New bottles of sealant can be purchased from your Aston Martin Dealer.

Fuel

 *The fuel tank filler neck has a restricted opening which will only accept the fuel supply nozzle of unleaded fuel pumps.*

Open the fuel flap by pressing down on the rear edge of the fuel flap. If the fuel flap will not open use the fuel flap emergency release.



The fuel system will not let the fuel tank overfill but there will be times when the fuel nozzle will shut off prematurely. If this happens only try to fill the fuel tank one more time, continued attempts will result in fuel spillage. Wait 10 seconds before removing the refuelling nozzle.

Fuel Filler Bowl

To stop water gathering in the fuel filler bowl and flowing into the fuel tank, the fuel filler bowl has a pipe to let the water drain from the bowl. During fuel filling, make sure that any debris which may block the pipe is removed.

Fuel Cut-Off

In the event of a vehicle accident the vehicle electronics will enter crash mode. Power to the fuel pumps will stop, thereby reducing fire risk.

Fuel Flap Emergency Release

To manually unlock the fuel flap:

1. The right side carpet for the luggage compartment (1) must be moved. Release the two fasteners (2) that attach the carpet and disconnect the luggage compartment lamp (3). Move the carpet.

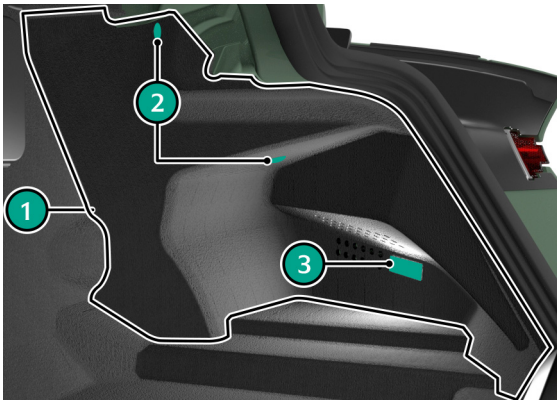

2. Reach behind the right side deck lid hinge.

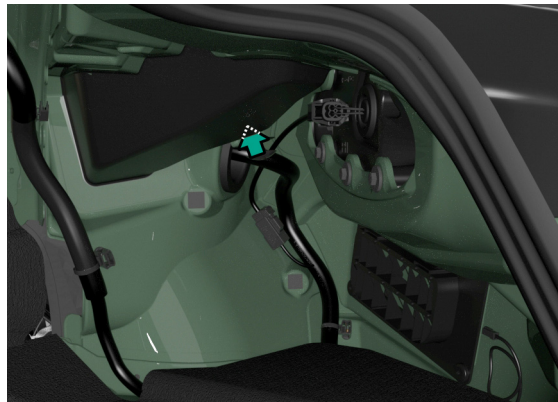

Software Updates

3. Pull the emergency release (ER) tab to unlock the fuel flap.

⚠ Caution: *The emergency release cable only unlocks the fuel flap. It does not open the fuel flap. Do not pull too hard on the emergency release cable as this can cause the emergency release cable to snap.*

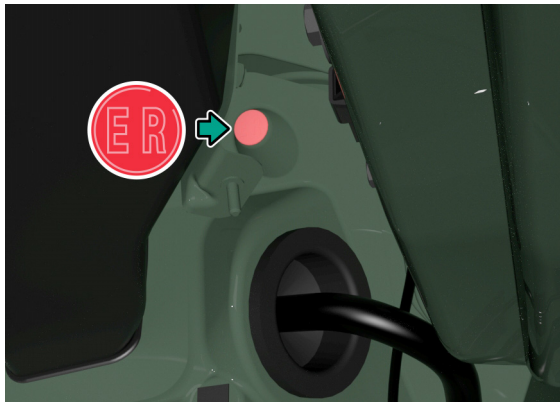

4. Open the fuel flap by pressing down on the rear edge of the fuel flap.

To have your vehicle operate at its best, there may be software updates that need to be installed on the infotainment. When a software update is available this will be shown as a notification on the **Software** screen in **System Settings** (Refer to 'Software', page 12.8) .

Update Process

To start a software update, tap the install button on screen and the software will be installed. For the installation to begin, the below conditions must be met:

- The vehicle must be stationary.
- The transmission must be in P (Park).
- The vehicle park brake must be applied.
- The vehicle battery must be above 80% charged.
- No ongoing eCall session.

If the above conditions are met then a legal disclaimer will be shown which must be agreed to continue. If there are any conditions that affect the vehicle such as a change to the selected drive mode being restricted, this will also be shown.

Once complete, a message will be shown to inform you of successful installation.



Service

Aston Martin Dealers	A.2
Vehicle Provenance.....	A.3
Servicing.....	A.5
Service Record.....	A.7
Replacement of Airbag Units.....	A.29
Replacement of Seat Belt Pre-tensioners.....	A.29
Brake Disc Check.....	A.30
Campaign Record	A.33

Aston Martin Dealers

A full list of Aston Martin Dealers can be found at:

www.astonmartin.com

Every effort is made to make sure that the information given in the dealer list is accurate and up-to-date. However changes amongst holders of the Aston Martin franchise can occur. Neither Aston Martin nor any listed Importer or Dealer shall in any circumstances be held liable for any inaccuracy, or the consequences thereof.

 *Aston Martin Dealers are also available as a point of interest (POI) in the satellite navigation system.*

Dealers all aim to conform to Aston Martin standards of excellence in both sales and service. However, all vehicles sold as Aston Martins are required to meet local legislation requirements. Should service be required in a country other than that in which this vehicle was originally purchased, every effort will be made to meet the owner's requirements, but the availability of certain parts may be affected by differences in vehicle and component specifications.

Aston Martin Dealers are independent traders, they are not the Company's Agents, and therefore have no authority to bind the Company or to enter into any financial or other commitments on the Company's behalf. Only Aston Martin Dealers are authorized to carry out warranty work.

Vehicle Provenance

Model:

Vehicle Identification Number:

As on the VIN plate

Body Colour:

Interior Primary Colour:

Interior Secondary Colour:

Stitch Colour:

Fascia Colour:

Jewellery Pack Colour:

First Owner

Selling Dealer

Delivery Date

Second Owner

Selling Dealer

Delivery Date

Third Owner

Selling Dealer

Delivery Date

Fifth Owner

Selling Dealer

Delivery Date

Fourth Owner

Selling Dealer

Delivery Date

Sixth Owner

Selling Dealer

Delivery Date

Servicing

Service Tables

Vehicle servicing is annual or at the distance specified in the oil service table, whichever occurs first.

The following service schedules are recommended for this vehicle. The schedules may be modified if necessary. Please consult your Aston Martin Dealer for details of any service schedule updates.

Item

Annual Service Inspections

Examine the condition, operation, adjustment and attachment of the below items:

Engine and transmission mounting system. Check for leaks.

Accessory drive belt.

Fuel system. Examine for leaks and wear.

Cooling system. Examine for leaks.

Air conditioning system.

Drive shafts.

Wheel arch liners and under body protection.

Suspension and steering system. Examine for leaks and wear.

Brake system including park brake. Examine for leaks and wear.

Wheels, tires and tire pressure monitoring system. Check tire pressures and adjust as necessary.

Exhaust system, heat shields and bypass valves. Check for leaks.

Lamp units and the vehicle horn.

Windscreen wiper blades and wash system including fluid levels and adjust accordingly. Examine for leaks and wear.

Occupant restraint systems including airbags, seatbelts and child seat attachment points.

Locks, latches and hinges. Check powered openings such as tailgate for correct operation. Lubricate any joints as necessary.

Instrument cluster and warning symbols.

Item	Interval
Fluids and Consumables	
Replace the engine oil and filter.	Refer to Table
Replace the spark plugs.	64,000 km / 40,000 miles
Replace engine coolant.	6 Years
Replace the air filters.	48,000 km / 30,000 miles
Replace the pollen filter (optional).	2 years
Replace the brake fluid.	2 years
Check and adjust the oil level in the rear differential.	Annual
Replace the oil in the rear differential.	64,000 km / 40,000 miles

Oil Service Tables

	Service Interval
Brazil	8,000 km / 5,000 miles
Canada	16,000 km / 10,000 miles
Chile	10,000 km / 6,200 miles
Mexico	16,000 km / 10,000 miles
Peru	8,000 km / 5,000 miles
United States of America	15,000 km / 9,300 miles

Service Record

Vehicle Model:

Registration Number:

Vehicle Identification Number (VIN):

Delivery Date:

Free Pre-delivery Inspection

Service Actions Checked:	Yes / No
Open Service Actions Completed:	Yes / No
Signature:	
Date:	

Service Information

Odometer:

Technician Name:

Date:

Next Service Due:

Authorized Dealer Stamp

Service Advisor Name:

Service Advisor Signature:

Service Details

Service Actions Checked: Yes / No

Air Filter Changed: Yes / No

Pollen Filter Changed: Yes / No

Spark Plugs Changed: Yes / No

Anti Corrosion Inspection: Yes / No

Fluids Changed:

Additional Service Information

Service Information

Odometer:

Technician Name:

Date:

Next Service Due:

Authorized Dealer Stamp

Service Advisor Name:

Service Advisor Signature:

Service Details

Service Actions Checked: Yes / No

Air Filter Changed: Yes / No

Pollen Filter Changed: Yes / No

Spark Plugs Changed: Yes / No

Anti Corrosion Inspection: Yes / No

Fluids Changed:

Additional Service Information

Service Information

Odometer:

Technician Name:

Date:

Next Service Due:

Authorized Dealer Stamp

Service Advisor Name:

Service Advisor Signature:

Service Details

Service Actions Checked: Yes / No

Air Filter Changed: Yes / No

Pollen Filter Changed: Yes / No

Spark Plugs Changed: Yes / No

Anti Corrosion Inspection: Yes / No

Fluids Changed:

Additional Service Information

Service Information

Odometer:

Technician Name:

Date:

Next Service Due:

Authorized Dealer Stamp

Service Advisor Name:

Service Advisor Signature:

Service Details

Service Actions Checked: Yes / No

Air Filter Changed: Yes / No

Pollen Filter Changed: Yes / No

Spark Plugs Changed: Yes / No

Anti Corrosion Inspection: Yes / No

Fluids Changed:

Additional Service Information

Service Information

Odometer:

Technician Name:

Date:

Next Service Due:

Authorized Dealer Stamp

Service Advisor Name:

Service Advisor Signature:

Service Details

Service Actions Checked: Yes / No

Air Filter Changed: Yes / No

Pollen Filter Changed: Yes / No

Spark Plugs Changed: Yes / No

Anti Corrosion Inspection: Yes / No

Fluids Changed:

Additional Service Information

Service Information

Odometer:

Technician Name:

Date:

Next Service Due:

Authorized Dealer Stamp

Service Advisor Name:

Service Advisor Signature:

Service Details

Service Actions Checked: Yes / No

Air Filter Changed: Yes / No

Pollen Filter Changed: Yes / No

Spark Plugs Changed: Yes / No

Anti Corrosion Inspection: Yes / No

Fluids Changed:

Additional Service Information

Service Information

Odometer:

Technician Name:

Date:

Next Service Due:

Authorized Dealer Stamp

Service Advisor Name:

Service Advisor Signature:

Service Details

Service Actions Checked: Yes / No

Air Filter Changed: Yes / No

Pollen Filter Changed: Yes / No

Spark Plugs Changed: Yes / No

Anti Corrosion Inspection: Yes / No

Fluids Changed:

Additional Service Information

Service Information

Odometer:

Technician Name:

Date:

Next Service Due:

Authorized Dealer Stamp

Service Advisor Name:

Service Advisor Signature:

Service Details

Service Actions Checked: Yes / No

Air Filter Changed: Yes / No

Pollen Filter Changed: Yes / No

Spark Plugs Changed: Yes / No

Anti Corrosion Inspection: Yes / No

Fluids Changed:

Additional Service Information

Service Information

Odometer:

Technician Name:

Date:

Next Service Due:

Authorized Dealer Stamp

Service Advisor Name:

Service Advisor Signature:

Service Details

Service Actions Checked: Yes / No

Air Filter Changed: Yes / No

Pollen Filter Changed: Yes / No

Spark Plugs Changed: Yes / No

Anti Corrosion Inspection: Yes / No

Fluids Changed:

Additional Service Information

Service Information

Odometer:

Technician Name:

Date:

Next Service Due:

Authorized Dealer Stamp

Service Advisor Name:

Service Advisor Signature:

Service Details

Service Actions Checked: Yes / No

Air Filter Changed: Yes / No

Pollen Filter Changed: Yes / No

Spark Plugs Changed: Yes / No

Anti Corrosion Inspection: Yes / No

Fluids Changed:

Additional Service Information

Service Information

Odometer:

Technician Name:

Date:

Next Service Due:

Authorized Dealer Stamp

Service Advisor Name:

Service Advisor Signature:

Service Details

Service Actions Checked: Yes / No

Air Filter Changed: Yes / No

Pollen Filter Changed: Yes / No

Spark Plugs Changed: Yes / No

Anti Corrosion Inspection: Yes / No

Fluids Changed:

Additional Service Information

Service Information

Odometer:

Technician Name:

Date:

Next Service Due:

Authorized Dealer Stamp

Service Advisor Name:

Service Advisor Signature:

Service Details

Service Actions Checked: Yes / No

Air Filter Changed: Yes / No

Pollen Filter Changed: Yes / No

Spark Plugs Changed: Yes / No

Anti Corrosion Inspection: Yes / No

Fluids Changed:

Additional Service Information

Service Information

Odometer:

Technician Name:

Date:

Next Service Due:

Authorized Dealer Stamp

Service Advisor Name:

Service Advisor Signature:

Service Details

Service Actions Checked: Yes / No

Air Filter Changed: Yes / No

Pollen Filter Changed: Yes / No

Spark Plugs Changed: Yes / No

Anti Corrosion Inspection: Yes / No

Fluids Changed:

Additional Service Information

Service Information

Odometer:

Technician Name:

Date:

Next Service Due:

Authorized Dealer Stamp

Service Advisor Name:

Service Advisor Signature:

Service Details

Service Actions Checked: Yes / No

Air Filter Changed: Yes / No

Pollen Filter Changed: Yes / No

Spark Plugs Changed: Yes / No

Anti Corrosion Inspection: Yes / No

Fluids Changed:

Additional Service Information

Service Information

Odometer:

Technician Name:

Date:

Next Service Due:

Authorized Dealer Stamp

Service Advisor Name:

Service Advisor Signature:

Service Details

Service Actions Checked: Yes / No

Air Filter Changed: Yes / No

Pollen Filter Changed: Yes / No

Spark Plugs Changed: Yes / No

Anti Corrosion Inspection: Yes / No

Fluids Changed:

Additional Service Information

Service Information

Odometer:

Technician Name:

Date:

Next Service Due:

Authorized Dealer Stamp

Service Advisor Name:

Service Advisor Signature:

Service Details

Service Actions Checked: Yes / No

Air Filter Changed: Yes / No

Pollen Filter Changed: Yes / No

Spark Plugs Changed: Yes / No

Anti Corrosion Inspection: Yes / No

Fluids Changed:

Additional Service Information

Service Information

Odometer:

Technician Name:

Date:

Next Service Due:

Authorized Dealer Stamp

Service Advisor Name:

Service Advisor Signature:

Service Details

Service Actions Checked: Yes / No

Air Filter Changed: Yes / No

Pollen Filter Changed: Yes / No

Spark Plugs Changed: Yes / No

Anti Corrosion Inspection: Yes / No

Fluids Changed:

Additional Service Information

Service Information

Odometer:

Technician Name:

Date:

Next Service Due:

Authorized Dealer Stamp

Service Advisor Name:

Service Advisor Signature:

Service Details

Service Actions Checked: Yes / No

Air Filter Changed: Yes / No

Pollen Filter Changed: Yes / No

Spark Plugs Changed: Yes / No

Anti Corrosion Inspection: Yes / No

Fluids Changed:

Additional Service Information

Service Information

Odometer:

Technician Name:

Date:

Next Service Due:

Authorized Dealer Stamp

Service Advisor Name:

Service Advisor Signature:

Service Details

Service Actions Checked: Yes / No

Air Filter Changed: Yes / No

Pollen Filter Changed: Yes / No

Spark Plugs Changed: Yes / No

Anti Corrosion Inspection: Yes / No

Fluids Changed:

Additional Service Information

Service Information

Odometer:

Technician Name:

Date:

Next Service Due:

Authorized Dealer Stamp

Service Advisor Name:

Service Advisor Signature:

Service Details

Service Actions Checked: Yes / No

Air Filter Changed: Yes / No

Pollen Filter Changed: Yes / No

Spark Plugs Changed: Yes / No

Anti Corrosion Inspection: Yes / No

Fluids Changed:

Additional Service Information

Service Information

Odometer:

Technician Name:

Date:

Next Service Due:

Authorized Dealer Stamp

Service Advisor Name:

Service Advisor Signature:

Service Details

Service Actions Checked: Yes / No

Air Filter Changed: Yes / No

Pollen Filter Changed: Yes / No

Spark Plugs Changed: Yes / No

Anti Corrosion Inspection: Yes / No

Fluids Changed:

Additional Service Information

Replacement of Airbag Units

Aston Martin recommend that all airbag units are replaced every 10 years from the date of manufacture. To make sure this is completed correctly and safely, this work should be carried out by your Aston Martin Dealership.

Airbag Replacement 10th Year

Odometer:

Date:

Signature:

Replacement of Seat Belt Pre-tensioners

Aston Martin recommend that all seat belt pre-tensioners units are replaced every 10 years from the date of manufacture. To make sure this is completed correctly and safely, this work should be carried out by your Aston Martin Dealership.

Seat Belt Pre-Tensioners Replacement 10th Year

Odometer:

Date:

Signature:

Airbag Replacement 20th Year

Odometer:

Date:

Signature:

Seat Belt Pre-Tensioners Replacement 20th Year

Odometer:

Date:

Signature:

Brake Rotor Check

At each brake pad change (per axle), the ceramic brake rotors are required to be cleaned, dried and weighed. Record the date of each brake pad change and rotor weight.

Brake Pads Changed - Brake Rotors Checked

Rotor Weight (Front Axle):	kg	kg
----------------------------	----	----

Rotor Weight (Rear Axle):	kg	kg
---------------------------	----	----

Odometer:

Signature:	Date:
------------	-------

Brake Pads Changed - Brake Rotors Checked

Rotor Weight (Front Axle):	kg	kg
----------------------------	----	----

Rotor Weight (Rear Axle):	kg	kg
---------------------------	----	----

Odometer:

Signature:	Date:
------------	-------

Brake Pads Changed - Brake Rotors Checked

Rotor Weight (Front Axle): kg kg

Rotor Weight (Rear Axle): kg kg

Odometer:

Signature: Date:

Brake Pads Changed - Brake Rotors Checked

Rotor Weight (Front Axle): kg kg

Rotor Weight (Rear Axle): kg kg

Odometer:

Signature: Date:

Brake Pads Changed - Brake Rotors Checked

Rotor Weight (Front Axle): kg kg

Rotor Weight (Rear Axle): kg kg

Odometer:

Signature: Date:

Brake Pads Changed - Brake Rotors Checked

Rotor Weight (Front Axle): kg kg

Rotor Weight (Rear Axle): kg kg

Odometer:

Signature: Date:

Brake Pads Changed - Brake Rotors Checked		
Rotor Weight (Front Axle):	kg	kg
Rotor Weight (Rear Axle):	kg	kg
Odometer:		
Signature:	Date:	

Brake Pads Changed - Brake Rotors Checked		
Rotor Weight (Front Axle):	kg	kg
Rotor Weight (Rear Axle):	kg	kg
Odometer:		
Signature:	Date:	

Brake Pads Changed - Brake Rotors Checked		
Rotor Weight (Front Axle):	kg	kg
Rotor Weight (Rear Axle):	kg	kg
Odometer:		
Signature:	Date:	

Brake Pads Changed - Brake Rotors Checked		
Rotor Weight (Front Axle):	kg	kg
Rotor Weight (Rear Axle):	kg	kg
Odometer:		
Signature:	Date:	

Aston Martin Warranty

1 Aston Martin Warranties.....	B.2
2 New Vehicle Limited Warranty	B.5
3 New Vehicle Limited Warranty Statement.....	B.6
4 What is not Covered under the Warranties	B.7
5 Customer Satisfaction Campaigns	B.11
6 Anti-Perforation Corrosion Warranty	B.12
7 Emissions Defect Warranty	B.12
8 Emissions Performance Warranty	B.13
9 California Emissions Warranties	B.16
10 How do I get Service under the Emissions Warranties.....	B.20
11 How do I handle Emergency Repairs to make sure they do not affect the Emissions Warranties.....	B.20
12 What Replacement Parts should I use.....	B.21
13 Preserve Your Emissions Warranty.....	B.22
14 Customer Satisfaction.....	B.22
15 The Better Business Bureau (BBB) Auto Line Program	B.23
16 State Warranty Enforcement Laws.....	B.25
17 Aston Martin Extended Service Contract.....	B.25
Owner And Vehicle Details	B.26

1 Aston Martin Warranties

This chapter contains information essential for the understanding of the Aston Martin warranties and for the implementation of any necessary Warranty rectification. It is recommended that you read this chapter carefully to familiarize yourself with the benefits available under the various warranties.

1.1 Warranty Communications

Any communications regarding Warranty should initially be addressed to your Aston Martin Dealer. If necessary, you may communicate with Aston Martin at the appropriate address listed.

National After Sales Manager,
Aston Martin Lagonda of North America Inc.
9920 Irvine Centre Drive,
Irvine,
CA 92618

Or:

Warranty Department
Aston Martin Lagonda Limited,
Banbury Road,
Gaydon,
Warwick,
CV35 0DB,
England

1.2 Warranties

All Aston Martin warranties are issued by Aston Martin Lagonda Limited on behalf of Aston Martin Lagonda of North America Inc., the sole authorized United States agent of Aston Martin vehicles.

The warranties provided herein are for the benefit of the original purchaser and any subsequent owner during the relevant Warranty Period (defined below) in the Serviced Countries (defined below).

An Aston Martin vehicle is built and homologated to support the Region for which it is manufactured and is compliant with the local regulatory requirements of that Region. As a result, the warranties cover Aston Martin vehicles that are built for and supplied to the Region.

For the purposes of this Owner's Guide, 'Region means one of the following territories:

- the Americas, including the United States, Canada, and South America; or
- the United Kingdom, Europe, Russia and South Africa; or
- the Middle East, North Africa and India; or
- Asia Pacific, including China, Japan, Taiwan, Hong Kong, Singapore, Australia and New Zealand.

'Serviced Countries' means either: (a) any country in the Region from which your Aston Martin vehicle was purchased, where there is an Aston Martin authorized dealer or repairer; or (b) any country agreed in writing with Aston Martin.

The warranties provided herein are for the benefit of the original purchaser and any subsequent owner during the relevant Warranty Period (defined below). The warranties cover Aston Martin vehicles that are built for and supplied to the Region.

The Warranty period for all Warranties (defined below) for vehicles begin on the date of first retail sale, or on the date of entry into demonstrator service, whichever comes first.

A summary of all Aston Martin warranties applicable to this vehicle (together the Warranties) are as follows:

a) New Vehicle Limited Warranty

Bumper to bumper: Three years, unlimited mileage.

b) Vehicle Anti-Perforation Corrosion Warranty

Period of cover: Ten years, unlimited mileage.

c) Vehicle Emission Warranties (Federal)

Emissions Defects Warranty: Three years or 36,000 miles of vehicle use.

*Certain emission parts:*¹ Eight years or 80,000 miles of vehicle use.

Emissions Performance Warranty: Two years or 24,000 miles of vehicle use.

¹ Catalytic convertor, the electronic emissions control unit and / or the on-board emissions diagnostic device (required eight years or 80,000 miles (129,000 km) coverage per Clean Air Act).

d) Vehicle Emission Warranties (Californian Vehicles)

Emissions Defect Warranty (Short Term): Three years or 50,000 miles of vehicle use.

*Emissions Defect Warranty (Long Term):*¹ Seven years or 70,000 miles of vehicle use.

Emissions Performance Warranty: Three years or 50,000 miles of vehicle use.

1.3 Changes to Vehicles

Aston Martin and its authorized dealers (the '**Dealers**') reserve the right to make changes in or additions to vehicles built or sold by them at any time without incurring any obligation to make the same or similar changes or additions to vehicles previously built or sold.

1.4 Reservation of Rights

Aston Martin and its Dealers reserve the right to provide post-Warranty repairs, conduct recalls, or extend the Warranty coverage period for certain vehicles or vehicle populations, at Aston Martin's sole discretion. The fact that Aston Martin provided such measures to a particular vehicle or vehicle population, does not in any way obligate Aston Martin to provide similar accommodations to other owners of similar vehicles.

1.5 Condition

As a fundamental condition of the Warranties, you are responsible for correctly using, maintaining and caring for your vehicle in accordance with the Aston Martin Owner's Guide (the '**Owner's Guide**'). Aston Martin recommends that you maintain copies of all maintenance records and receipts for review by Aston Martin.

¹. These specific parts were selected on the basis of their estimated replacement cost at the time your vehicle was certified by the California Air Resources Board (CARB) for sale in California.

2 New Vehicle Limited Warranty

2.1 Warranty Limitations

This New Vehicle Limited Warranty is the only express Warranty applicable to your vehicle. Aston Martin neither assumes, nor authorizes anyone to assume for it, any other obligation or liability in connection with this Warranty. No person, including Aston Martin employees or Dealers, can modify or waive any part of this Warranty.

a) Limitation of Remedies

Under this Warranty, it is agreed that the sole exclusive remedy against Aston Martin and its authorized Dealers shall be for the repair or replacement of defective parts as provided herein. The sole purpose of this exclusive remedy shall be to provide for the free repair and replacement of defective parts in the manner prescribed in this Warranty.

This exclusive remedy shall not be deemed to have failed its essential purpose so long as Aston Martin, through its authorized Dealers, is willing and able to repair or replace defective parts in the prescribed manner.

Aston Martin and its Dealers are not responsible to you for any time or income that you lose, any inconvenience you might be caused, the loss of your transportation or use of your vehicle, the cost of rental vehicles, fuel, telephone, travel, meals or lodging, the loss of personal or commercial property, the loss of revenue, or for any other incidental or consequential damages you may have. Punitive, exemplary, or multiple damages can not be recovered unless applicable law prohibits their disclaimer. You may not bring any warranty-related claim as a class representative, a private attorney general, a member of a class of claimants or in any other representative capacity.

Aston Martin shall not be liable for any damages caused by delay in delivery or furnishing of any products and /or services.

3 New Vehicle Limited Warranty Statement

b) Implied Warranties and Consequential Damages

Under the law of some States, you as the owner may be entitled to the benefit of the implied warranties of merchantability or fitness for intended purpose. These implied warranties are limited to the extent allowed by law to the time period covered by the written warranties, or the applicable time period provided by State Law, whichever period is shorter.

Some States do not permit a limitation on how long an implied warranty will last, or on the exclusion or limitation of incidental or consequential damages, so the above limitation may not apply to you. This warranty gives owners specific legal rights, and they may also have other rights that vary from State to State.

3.1 Warranty Maintenance

Aston Martin warrants that during the Warranty period, if an Aston Martin vehicle is correctly operated and maintained by the user in accordance with the Maintenance chapter of the Owner's Guide, repairs required to correct defects in materials or workmanship will be performed without charge; any component covered by this Warranty found to be defective in materials or workmanship, will be repaired, or replaced, without charge. Your Aston Martin Dealer will repair the vehicle with genuine approved Aston Martin parts.

3.2 Warranty Coverage

The New Vehicle Limited Warranty covers any original or OEM component of the Aston Martin vehicle that is defective during the basic Warranty period, with the exception of tires, the items listed under section 4.4, normal maintenance items and regularly scheduled maintenance parts and labor. The Warranty includes any part scheduled for routine replacement during the Warranty period only if it is defective. If a part fails at the same time it is due for replacement it is not covered by the Warranty.

4 What is not Covered under the Warranties

4.1 Excluded Categories of Vehicle

The following categories of vehicle are excluded from the provisions of the Warranties:

- Vehicles sold for hire.
- Vehicles used for motor sport, competition and track events (except Aston Martin organized and managed events).
- Vehicles that are incorrectly maintained.

4.2 Damage Caused by Accident, Alteration or Misuse

The Warranties do not cover:

- Damage caused by collision, fire, flood, theft, freezing, vandalism, riot, explosion, or objects striking the vehicle.
- Misuse of the vehicle, such as driving over curbs, overloading, racing, or using the vehicle as a stationary power source.
- Defects caused as a result of the vehicle being in motor sport or track events.
- Alterations or modifications of the vehicle (including changes to the body, chassis, or components) carried out on the vehicle, at any time during its lifetime, by non-approved repairers or body repair centres and shops, tampering with the vehicle, tampering with the emission systems or with other parts that affect these systems.
- Disconnection or alteration of the odometer, or where the actual mileage cannot be determined due to the odometer being inoperative for an extended period of time.
- Use of contaminated or incorrect fuel or fluids or application of unauthorized chemicals by the customer.

4.3 Damage Caused by Use or the Environment

Surface rust, deterioration and damage of paint, trim, upholstery and other appearance items that result from use and / or exposure to the elements are not covered under any of the Warranties.

The Warranties do not cover:

- Stone chips, scratches
- Lightning, hail damage
- Dints or dents
- Windstorm damage
- Road salt, tree sap
- Earthquake damage
- Bird and insect droppings
- Freezing, water or flood damage
- Cuts, burns, punctures or tears
- Windshield stress cracks
- Rodent damage
- Incorrect polishing of paint surface.

4.4 Damage Caused by Failure to Maintain or Incorrect Maintenance

Damage caused by failure to maintain the vehicle, incorrect maintenance of the vehicle, or using the wrong fuel, oil, lubricants, or fluids is not covered under the Warranties. Refer to the Specifications chapter of the Owner's Guide for correct fluid levels, and for information on the correct ways to maintain your vehicle.

Examples of important maintenance procedures that need to be done correctly are:

- Oil changes
- Cleaning and polishing
- Oils, lubricants and other fluids
- Engine tune-up
- Oil and air filters
- Wiper blades
- Brake pads and lining
- Tire rotation, inflation
- Wheel alignments and tire balancing.

4.5 Other Items and Conditions Not Covered by the Warranties

The Warranties do not cover:

- The installation or use of a non-Aston Martin part (other than a certified emissions part) or any part (Aston Martin or non-Aston Martin) designed for off-road use only installed after the vehicle leaves the control of Aston Martin, if the installed part fails or causes an Aston Martin part to fail.
 - Damage to, or caused by, non-approved accessories such as alarms, telephones.
 - Damage to, or caused by, non-approved snow chains or towing devices.
 - Damage caused by failure to maintain adequate levels of fuel in your vehicle.
 - Vehicles that have been labeled or branded as being 'dismantled', 'fire', 'flood', 'junk', 'rebuilt', 'reconstructed', 'salvaged' – this will void the Warranties.
 - Vehicles that have been determined as a 'total loss' by an insurance company, or other official body – this will void the Warranties.
 - Service adjustments, wear items and alignments after one (1) year or 10,000 miles, whichever occurs first.
-
- Use of alternative fuels: Aston Martin does not recommend or approve of the use of Liquid Petroleum gas or Compressed Natural gas. Damage caused by the use of alternative fuels or fuel additives is not covered by the vehicle warranty.
 - Normal wear or worn out tires. Tires will not be replaced (unless required by a warranty repair) for wear or damage including a) tire damage from road hazard such as cuts, snags, bruises, bulges, puncture, and impact breaks; and b) tire damage due to under or over inflation, tire chain use, racing, spinning (including when stuck in snow or mud), incorrect mounting or dismounting, or tire repair.
 - Vehicles that have had the odometer disconnected, altered, or inoperative for an extended period of time with the result that the actual mileage cannot be determined.
 - Use of a fuel not approved or recommended by Aston Martin in the Owner's Guide is considered misfuelling, and that any damage resulting from misfuelling is not covered by the vehicle warranty.

4.6 Wear and Tear Items

Items that are subject to wear and tear are generally divided into two categories, namely those specified for replacement or adjustment during scheduled maintenance and those that require replacement or adjustment dependent upon conditions of use.

a) Scheduled Maintenance Items

The items listed below are covered by the Vehicle Warranty up to the first scheduled change point that replacement or adjustment is required during scheduled maintenance operations.

- Drive belts
- Spark plugs
- Oil, air, pollen and fuel filters.

 *The period of warranty cover for any item may not exceed the time and distance limitation of the vehicle warranty.*

b) Other Items

The items listed below are recognized as having a limited service life or are subject to wear or damage. However, these items are covered by the vehicle warranty for up to one year or the first service, whichever ever occurs first.

- Wiper blades
- Wheel alignment and balancing
- Adjustments, including, but not limited to: headlamp and hinged panel adjustments, suspension tightening, emission and fuel systems checks and steering geometry adjustments.
- Remote transmitter batteries.

 *Brake pads, brake rotors and other friction related components are not covered when replacement is due to wear and tear, but they are covered against manufacturing defects for the duration of the Vehicle Warranty.*

5 Customer Satisfaction Campaigns

c) Consumables

Replacement or 'top-up' of consumable fluids, e.g. oils, anti-freeze, brake fluid, windshield wash solution and refrigerant, is only covered when they are used as part of a warranty repair.

In order to maintain a high level of customer confidence and satisfaction with Aston Martin products, Aston Martin may periodically determine that certain service procedures are necessary, and will assume costs for same, in whole or in part, independent of the New Vehicle Limited Warranty. When repairs to your vehicle are covered by the terms of one of these policy adjustments, your Aston Martin Dealer will advise you of the extent to which Aston Martin will pay either for parts, or for labor, or both.

If you have a question regarding a possible extra-Warranty adjustment, an authorized Aston Martin Dealer or Aston Martin can provide the details when the year, model and Vehicle Identification Number (VIN) are supplied.

Aston Martin reserves the right to make modifications in vehicles manufactured or sold by them at any time without incurring any obligation to make the same or similar modifications in vehicles previously manufactured or sold by them.

6 Anti-Perforation Corrosion Warranty

The vehicle bodywork is protected by an Anti-Perforation Corrosion Warranty. Should any part of the bodywork of the Aston Martin vehicle be perforated the panel(s) affected by the perforation will be repaired or replaced. The term 'perforation' means a hole that penetrates from the inner surface of a body panel or box section outwards. A pre-condition of supporting this Warranty is an annual Dealer inspection.

7 Emissions Defect Warranty

7.1 Federal Requirements

Aston Martin provides coverage under the Emissions Defect Warranty (including labor and diagnosis) for repairs of emissions related parts which become defective on vehicles with the following years of service or mileage (whichever occurs first):

Parts	Years in Service	Mileage
Emissions Related Parts	3	36,000
Certain Emissions Parts ¹	8	80,000

¹ Means the catalytic converter, the engine control module, the transmission control module and / or the on-board emissions diagnostic device.

During the Warranty coverage period, Aston Martin warrants that:

- Your vehicle or engine is designed, built and equipped to meet (at the time it is sold) the applicable emissions regulations of the US Environmental Protection Agency (EPA).
- Your vehicle or engine is free from defects in factory-supplied Materials or workmanship that could prevent it from conforming with applicable EPA regulations.
- You will not be charged for repair, replacement, or adjustment of defective Emissions Related Parts (defined under section 8.2, What is Covered).

8 Emissions Performance Warranty

8.1 Federal Requirements

If your vehicle is registered in a State where the State or Local Government has an EPA - approved inspection and maintenance program, any repairs which are required on your vehicle may also be covered under the Emissions Performance Warranty if your vehicle has the following years service or mileage (whichever occurs first) and if you meet certain conditions noted below:

Parts	Years in Service	Mileage
Emissions Related Parts	2	24,000
Certain Emissions Parts ¹	8	80,000

¹. Means the catalytic converter, the engine control module, the transmission control module and / or the on-board emissions diagnostic device.

Under the Emissions Performance Warranty, Aston Martin will repair, replace, or adjust (with no charge for labor, diagnosis, or parts) any emissions control device or system, if you meet all of the following conditions:

- You have maintained and operated your vehicle according to the instructions on correct care and scheduled maintenance contained in the Owner's Guide.
- Your vehicle fails to conform, during the warranty coverage period to the applicable national EPA standards, as determined by an EPA approved inspection and maintenance program.
- You are subject to a penalty or sanction under local, State or Federal Law because your vehicle has failed to conform to the emissions standards (a penalty or sanction includes being denied the right to use your vehicle).
- Your vehicle has not been tampered with, misused, or abused.

The Emissions Performance Warranty will not apply to your vehicle if the diagnosis on your vehicle shows your vehicle will pass the applicable State or Local Government test using test procedures and standards set by the EPA.

8.2 What is Covered

If the following parts contain an emissions- related defect (an **'Emissions Related Part'**) they will be covered by both the Emissions Defect Warranty (set out in section 7) and the Emissions Performance Warranty:

- Air and Fuel Feedback Control System and Sensor
- Air Filter Housing
- Altitude Compensation System
- Camshaft Position Sensor
- Catalytic Converter
- Charge Air Cooler
- Controls for Deceleration
- Electronic Ignition System
- Electronic Engine Control Sensors and Switches
- Exhaust Gas Recirculation (EGR) Valve, Spacer, Plate and Associated Parts
- Exhaust Heat Control Valve
- Exhaust Manifold and Gasket
- Fuel Delivery Module
- Fuel Filter
- Fuel Injector
- Fuel Pressure Temperature Sensor
- Fuel Rail Assembly
- Fuel Tank

- Fuel Vapour Storage Canister, Liquid Separator and Associated Controls
- Ignition Coil and / or Control Module
- Intake Manifold (Includes Boost Air Distribution Lines)
- Instrument Cluster (Malfunction Indicator Lamp)
- PCV System and Oil Filler Cap
- Engine Control Module
- Transmission Control Module
- Pulsed Secondary Air Injection Valve / Secondary Air Injection Pump and Associated Parts
- Spark Control Components
- Spark Plugs
- Throttle Air Control By-pass Valve
- Throttle Body Assembly
- Turbocharger
- Volume Air Flow Sensor.

 *Some items and equipment in this list may not be installed to this vehicle and therefore may not be applicable.*

Also covered by the Emissions Defect Warranty and the Emissions Performance Warranty are all emissions-related bulbs, hoses, clamps, brackets, tubes, gaskets, seals, belts, connectors, and wiring harnesses that are used with components in the list of parts set out above.

8.3 Parts Replaced on Regular Maintenance Schedules

Parts that should be replaced on a certain recommended maintenance schedule, remain under warranty until, (a) the first replacement time that is specified under Service in your Owner's Guide or, (b) the time or mileage limits of the Federal Defect and Performance Warranties (whichever occurs first). Aston Martin maintains a complete list of parts covered by Emissions Warranties. For more details about the specific parts covered by the Emissions Defect Warranty, contact Aston Martin or Aston Martin Lagonda of North America Inc. (Refer to '1.1 Warranty Communications', page B.2)

8.4 What is Not Covered

Aston Martin may deny you coverage under the Emissions Warranties if your vehicle or a part does not contain an emissions-related defect or has failed due to abuse, neglect, incorrect maintenance, unapproved modifications, or it concerns any items included in section 4 (What is not covered under the Warranties).

9 California Emissions Warranties

9.1 Your Warranty Rights and Obligations

This Warranty is applicable if your vehicle is both:

- a) Registered in California, or other States adopting California emission and warranty regulations.¹
- b) Certified for sale in California as indicated on the vehicle emission control information label.

Aston Martin and the California Air Resources Board are pleased to explain the emission control system Warranty on your Aston Martin vehicle.

In California, new motor vehicles must be designed, built, and equipped to meet the State's stringent anti-smog standards.

Aston Martin must warrant the emission control system on your vehicle for the periods of time listed under the Manufacturer's Warranty Coverage, provided there has been no abuse, neglect, or incorrect maintenance of your vehicle.

Your emission control system may include parts such as the fuel injection system, the ignition system, catalytic converter, and the engine computer. Also included may be hoses, belts, connectors, and other emissions-related assemblies.

Where a warrantable condition exists, Aston Martin will repair your vehicle at no cost to you including diagnosis, parts, and labor.

¹ Other States adopting California emissions and warranty regulations: Passenger car & light-duty trucks (up to 8,500 pounds GVWR) – California, Connecticut, Maine, Massachusetts, New Jersey, Oregon, Pennsylvania, Rhode Island, Vermont, Washington and any other States that adopt the California emissions and warranty regulations from time to time.

9.2 Manufacturer's Warranty Coverage

For vehicles eligible for coverage under the California Emissions Warranty, if your vehicle is:

a) Three years in service or has mileage of 50,000 miles (whichever first occurs):

- If your vehicle fails a Smog Check inspection, all necessary repairs and adjustments will be made by Aston Martin to make sure that your vehicle passes the inspection. This is your **Emission Control System Performance Warranty**.
- If an emission related part (as defined in section 9.5) on your vehicle is defective, the part will be repaired or replaced by Aston Martin. This is your **Short-Term Emission Control System Defects Warranty**.

b) Seven years in service or has mileage of 70,000 miles (whichever first occurs):

- If an emission related part (as defined in section 9.6) on your vehicle is defective, the part will be repaired or replaced by Aston Martin. This is your **Long-Term Emission Control System Defects Warranty**.

9.3 Owner's Warranty Responsibilities

As the vehicle owner or lessee, you are responsible for the performance of the required maintenance listed in the Owner's Guide. Aston Martin recommends that you retain all receipts covering maintenance on your vehicle, but Aston Martin cannot deny warranty coverage solely for the lack of receipts or for your failure to check the performance of all scheduled maintenance.

You are responsible for presenting your vehicle to an Aston Martin Dealer as soon as a problem exists. The warranty repairs should be completed in a reasonable amount of time, not to exceed 30 days.

Aston Martin may deny warranty coverage if your vehicle or a part has failed due to abuse, neglect, improper maintenance, or unapproved modifications.

If you have any questions regarding your warranty rights and / or responsibilities, or if you want to report what you believe to be violations of the terms of this Warranty, you may contact Aston Martin Lagonda of North America Inc. After Sales Department:

Tel: (866) 278 6661

or the California Air Resources Board at:

State of California Air Resources Board,
9528 Telstar Avenue,
El Monte,
California 91731

9.4 General Emissions Warranty Coverage

Aston Martin warrant to the ultimate purchaser and each subsequent purchaser that the vehicle is:

(1) Designed, built, and equipped so as to conform with all applicable regulations adopted by the Air Resources Board pursuant to its authority in chapters 1 and 2, part 5, division 26 of the Health and Safety Code; and

(2) Free from defects in materials and workmanship which cause the failure of a warranted part to be identical in all material respects to the part as described in the vehicle or engine manufacturer's application for certification, including any defect in materials or workmanship which would cause the vehicle's on-board diagnostic malfunction indicator light to illuminate, for a period of three years or 50,000mi, whichever first occurs; and

(3) Free from defects in materials and workmanship which cause the failure of a warranted part described in 'Long Term Emission Control Systems Defect Warranty' below for seven years or 70,000mi, whichever first occurs.

9.5 What is Covered under the Short Term Emission Control System Defects Warranty

The parts in the following list are covered by Emission Control System Defects Warranties, which apply to every California model vehicle manufactured from, and including, 2004.

- Air and Fuel Feedback Control System and Sensor
- Air Filter Housing
- Altitude Compensation System
- Camshaft Adjuster
- Camshaft Position Sensor
- Carbon Canister
- Catalytic Converter
- Charge Air Cooler
- Controls for Deceleration
- Electronic Ignition System
- Electronic Engine Control Sensors and Switches
- Exhaust Gas Recirculation (EGR) Valve, Spacer, Plate and Associated Parts
- Exhaust Gas Oxygen Sensors
- Exhaust Heat Control Valve
- Exhaust Manifold and Gasket
- Fuel Filler Neck
- Fuel Delivery Module
- Fuel Filter
- Fuel Injector

- Fuel Level Sender
- Fuel Rail Assembly
- Fuel Tank
- Fuel Vapour Storage Canister, Liquid Separator and Associated Controls
- Ignition Coil and / or Control Module
- Intake Manifold (Includes Boost Air Distribution Lines)
- Instrument Cluster (Malfunction Indicator Lamp)
- PCV System and Oil Filler Cap
- Engine Control Module
- Transmission Control Module
- Pulsed Secondary Air Injection Valve / Secondary Air Injection Pump and Associated Parts
- Spark Control Components
- Spark Plugs
- Throttle Air Control By-pass Valve
- Throttle Body Assembly
- Turbocharger
- Volume Air Flow Sensor.

 *Some items and equipment in this list may not be installed to this vehicle and therefore may not be applicable.*

9.6 What is Covered under the Long Term Emission Control System Defects Warranty

The parts in the following list are covered by Emission Control System Defects Warranties, which apply to every California model vehicle manufactured from, and including, 2004.

- Catalysts - Downpipe and Underfloor
- Camshaft Position Sensor
- Carbon Canister
- Exhaust Gas Oxygen Sensors
- Exhaust Manifold and Gasket
- Fuel Delivery Module
- Fuel Level Sender
- Fuel Rail Assembly
- Fuel Tank
- Intake Manifold
- Engine Control Module
- Transmission Control Module
- Pulsed Secondary Air Injection Valve / Secondary Air Injection Pump and Associated Parts
- Throttle Body Assembly
- Volume Air Flow Sensor.

 *Some items and equipment in this list may not be installed to this vehicle and therefore may not be applicable.*

10 How do I get Service under the Emissions Warranties

To get service under your Emissions Warranties, take your vehicle to any Aston Martin Dealer as soon as possible after it has failed an EPA - approved test or a California Smog Check inspection. You must show the Dealer the document that states your vehicle has failed the test.

The Dealer will decide whether the repair is covered by the Warranty. If the Dealer cannot make a decision with regard to coverage under your Emissions Warranty, the Dealer shall forward the query to Aston Martin.

Aston Martin shall procure to make a final decision within 30 days after you bring your vehicle in for repair. (The decision will be made within a shorter time if the law requires you to have the vehicle repaired more quickly in order to avoid additional penalties.)

However, if you request a delay, agree to a delay, or if a delay is caused by an event for which neither Aston Martin nor your Aston Martin Dealer is responsible, the deadline for determination does not have to be met by Aston Martin.

If a question about Emissions Warranty coverage is referred to Aston Martin, you will be notified by Aston Martin in writing if your claim for Emissions Warranty coverage is denied. The notice will explain the basis for denying your claim.

11 How do I handle Emergency Repairs to make sure they do not affect the Emissions Warranties

Aston Martin strives to make sure that services are available to conduct emergency repairs on your vehicle when necessary. However, occasionally, Aston Martin may not be able to perform emergency repairs for reasons outside of its control.

If your vehicle requires an emergency repair on Emission Related Parts and an Aston Martin Dealer is 'unavailable or unable to perform the necessary repairs' (defined below), you may, but only as a last resort, procure repairs by someone other than an authorized Aston Martin Dealer (a '**Third Party**').

If the Dealer or, failing a decision by the Dealer, Aston Martin, determines that such repair is covered under Warranty, Aston Martin will reimburse you for the cost of such repairs, including diagnosis.

Make sure that you obtain and take the following to your Aston Martin Dealer within 30 days of the repairs having been performed:

- a) The parts that are replaced, and
- b) A receipt for the work.

The term 'unavailable or unable to perform the necessary repairs' means:

12 What Replacement Parts should I use

- If you have informed Aston Martin of the required emergency repairs and either Aston Martin or the Aston Martin Emergency Service roadside assistance service provider is unable to take your vehicle to an accessible authorized Aston Martin Dealer.
- If an authorized Dealer is unable to perform the necessary repairs.
- If an authorized Dealer does not have the warranted part required to perform the necessary repairs.

Aston Martin shall only reimburse you if the repairs are conducted by a Third Party within 30 days from the time you first bring your vehicle to the Dealer for repairs and the time it is repaired by the Third Party.

Any repair that is not completed within the 30 day period may (at Aston Martin's discretion) constitute an emergency and any equivalent replacement part may be used in an emergency situation. If Aston Martin determines that the repair is covered under Warranty, Aston Martin will reimburse you for the repair expenses if:

- a) It does not exceed the Aston Martin's suggested retail price for all warranted parts that are replaced and,
- b) The labor charges do not exceed the Aston Martin's recommended time allowance for the Warranty repair and the labor charges are reasonable and similar to those charged by a repairer of similar geographical location.

Aston Martin recommends that you use genuine Aston Martin replacement parts. However, when you are having non-Warranty work done on your vehicle, you may choose to use non-Aston Martin parts of equivalent specification.

If you decide to use non-Aston Martin parts, make sure that they are equivalent to Aston Martin parts in performance, quality and durability. If you use replacement parts that are not equivalent to Aston Martin parts, your vehicle's emissions control systems may not work as effectively, and you may jeopardize your Emissions Warranty coverage.

 *The maintenance, replacement, or repair of emissions control devices or systems, the cost of which is not covered by the Warranties, can be performed by any automotive repair establishment or individual using non-Aston Martin parts.*

For vehicles within the Warranty period, Aston Martin will repair at no cost to the owner, under the Federal Emissions Warranty, covered emission failures caused by correctly installed Aston Martin parts or non-Aston Martin parts that have been 'certified' by the U.S. Environmental Protection Agency (EPA). Aston Martin is not responsible for the cost of repairing any emission failures caused by non-Aston Martin parts that have not been 'certified' by the EPA.

13 Preserve Your Emissions Warranty

If you do not maintain your vehicle correctly, Aston Martin may have the right to deny you coverage under any of its Emissions Warranties.

To have repairs made under the Emissions Warranties, you may be required to show that you have followed Aston Martin's instructions on correctly maintaining and using your vehicle, in accordance with the instructions set out in the Owner's Guide. Make sure that you save your service receipts and keep accurate records of any maintenance work performed.

If you are not satisfied with the handling of a Warranty matter, you may contact Aston Martin Lagonda of North America Inc. If you need more information about getting service under the Federal Emissions Performance Warranty, or if you want to report what you believe to be violations of the terms of this Warranty, you may contact:

Director Vehicle Program and Compliance Division
(6505J),
Environmental Protection Agency,
401 M Street, S.W.,
Washington,
DC 20460

14 Customer Satisfaction

If you are not satisfied with any Warranty repairs performed by an authorized Aston Martin Dealer and feel that you have a legitimate Warranty concern that is not being addressed to your satisfaction, follow the steps recommended below for the best resolution.

Step 1: Raise your concerns with the authorized Dealer Service Manager.

If you feel it would help clarify any concern, you should accompany the Service Manager on test drive of vehicle to demonstrate your issues and concerns. Often simply voicing your concerns directly to a manager or with the trained technician results in a satisfactory repair.

Step 2: If you are still not satisfied, contact dealership owner or General Manager.

Often raising an unresolved issue to a General Manager will benefit all involved and bring a focussed effort from all parties involved.

Step 3: If you are still not satisfied, bring concerns to Aston Martin Lagonda of North America Inc. Regional After Sales Manager or Operations Manager.

All authorized Aston Martin Dealers have the contact details of the relevant After Sales and Operations Managers. Ask for the Aston Martin contact information and it will be gladly supplied.

Step 4: If you are still not satisfied, either:**a) Seek arbitration**

All disputes relating to the Warranty or the Extended Service Contract shall be resolved by binding arbitration under the Rules of Commercial Arbitration of the American Arbitration Association including its Supplementary Procedures for Consumer Related Disputes, before a single arbitrator who shall be bound by the terms of this Document. To maintain the highest quality of service and for staff training purposes, telephone calls to Aston Martin may be monitored and / or recorded.

b) If your dispute is in the State of California, contact the Better Business Bureau (BBB)

 *The BBB program is only in effect in the State of California, but steps one through three should be followed for quickest result.*

As a final step to make sure that your concerns are being fairly considered, Aston Martin has agreed to participate in a dispute settlement program administered by the BBB, at no cost to the customer.

Refer to section 15 for further details of the BBB.

15 The Better Business Bureau (BBB) Auto Line Program

(California only)

The Better Business Bureau (BBB) works with manufacturers and their customers in an attempt to reach a mutually acceptable resolution of any Warranty related concerns. If a Warranty concern has not been resolved using the three-step procedure outlined in Customer Satisfaction (Refer to '14 Customer Satisfaction', page B.22), you may be eligible to participate in the BBB Auto Line Program.

The BBB Auto Line Program consists of two parts – mediation and arbitration. During mediation, a representative of the BBB will contact both you and Aston Martin to explore options for settlement of the claim. If an agreement is not reached during mediation and your claim is eligible, you may participate in the arbitration process and the BBB will schedule an arbitration hearing so that you can present your case in an informal setting before an impartial person. The arbitrator will consider the testimony provided and make a decision after the hearing.

B.24 Aston Martin Warranty

You are not bound by the decision, but should you choose to accept the BBB Auto Line decision, Aston Martin shall abide by the accepted decision as well and will comply with the decision within a reasonable time not to exceed 30 days after the manufacturer receives notice of the consumer's acceptance of the decision.

You may reject the BBB Auto Line decision and go to court but the decision and any findings will be admissible in any court action

Disputes submitted to the BBB Auto Line Program are usually decided within 40 days after you file your claim with BBB. If you wish to use the program and you qualify for participation, you will be required to provide the following information:

- Your name and address
- The Vehicle Identification Number (VIN)
- The make, model and year of your vehicle
- A description of the problem with your vehicle.

BBB AUTO LINE will also ask you for other information that may help resolve your concerns, such as the purchase price of your vehicle, the vehicle's current mileage, and copies of repair orders.

Upon receipt of such information, BBB will review the claim for eligibility under the Program Summary Guidelines.

You are required to resort to BBB AUTO LINE before exercising rights or seeking remedies under the Federal Magnuson-Moss Warranty Act, 15 U.S.C. § 2301 et seq. To the extent permitted by the applicable State 'Lemon Law', you are also required to resort to BBB AUTO LINE before exercising any rights or seeking remedies under the 'Lemon Law'. If you choose to seek remedies that are not created by the Magnuson-Moss Warranty Act or the applicable State 'Lemon Law', you are not required to first use BBB AUTO LINE.

For more information about BBB AUTO LINE, including current eligibility standards, call 1-800-955-5100, visit the BBB website at www.bbbprograms.org, or write to the BBB at:

BBB AUTO LINE,
1676 International Drive,
Suite 550
McLean VA 22102

16 State Warranty Enforcement Laws

These State laws (sometimes called '**lemon laws**') allow owners to receive a replacement vehicle or a refund of the purchase price, under certain circumstances. The laws vary from State to State.

To the extent your State Law allows, Aston Martin requires that you first send us a written notification of any defects or non-conformities that you have experienced with your vehicle. This will give us the opportunity to make any necessary repairs before you pursue the remedies provided by your State's law.

In other States, where not specifically required by State Law, Aston Martin requests that you send us written notification to:

National After Sales Manager,
Aston Martin Lagonda of North America Inc.,
9920 Irvine Center Drive,
Irvine CA 92618

17 Aston Martin Extended Service Contract

You may purchase an Aston Martin Extended Service Contract (ESC) which shall protect your vehicle for an extended period after the expiry of your New Vehicle Limited Warranty.

The ESC provides:

- a) Protection against covered repair costs. (Wear items, neglect, force majeure and damage caused by outside influence are excluded, and shall be left to the sole discretion of Aston Martin.).
 - b) Aston Martin Emergency Assistance roadside support.
 - c) Zero deductible, which means that you will not pay for covered repairs in the case of a legitimate claim.
 - d) 12 or 24 months coverage across the USA and Canada.
- Aston Martin offers various ESC products of varying levels of cover dependent upon the age and mileage of the vehicle. All vehicles must pass an Aston Martin multi-point inspection prior to the registration of an ESC on a vehicle.

Please note that the ESC Terms and Conditions shall apply. For a full list of the ESC Terms and Conditions, or if you would like to arrange such cover, talk to your nearest participating Aston Martin Dealer.

Owner And Vehicle Details

Name:

Address:

:

:

:

Post Code:

Signature:

Date:

Dealer Stamp

Registration Plate No.:

VIN No.:

Engine No.:

Warranty Start Date:

If the vehicle is sold, the benefits of any un-expired portion of the warranties can be transferred to the new owner.

The new owner should complete a 'tear off' sheet (next page) and send the new details to:

Aston Martin Warranty Department
Aston Martin Lagonda Limited
Banbury Road
Gaydon
Warwick
CV35 0DB
England

Owner Warranty Transfer (2)

VIN No.:

Odometer:

Date of Purchase:

Name:

Address:

:

:

Post Code:

Telephone No.:

Email Address:

Signature:

Date:

Owner Warranty Transfer (1)

VIN No.:

Odometer:

Date of Purchase:

Name:

Address:

:

:

Post Code:

Telephone No.:

Email Address:

Signature:

Date:



Owner Warranty Transfer (4)

VIN No.:

Odometer:

Date of Purchase:

Name:

Address:

:

:

Post Code:

Telephone No.:

Email Address:

Signature:

Date:

Owner Warranty Transfer (3)

VIN No.:

Odometer:

Date of Purchase:

Name:

Address:

:

:

Post Code:

Telephone No.:

Email Address:

Signature:

Date:



Owner Warranty Transfer (6)

VIN No.:

Odometer:

Date of Purchase:

Name:

Address:

:

:

Post Code:

Telephone No.:

Email Address:

Signature:

Date:

Owner Warranty Transfer (5)

VIN No.:

Odometer:

Date of Purchase:

Name:

Address:

:

:

Post Code:

Telephone No.:

Email Address:

Signature:

Date:



Aston Martin Assistance

Aston Martin Roadside Assistance	C.2
How Does the Plan Work	C.3
Further Information.....	C.3

Aston Martin Roadside Assistance

In the event of a breakdown caused by a defect covered under the New Vehicle Limited Warranty, the Aston Martin Roadside Assistance scheme will provide the Aston Martin owner with emergency roadside assistance at no cost. The scheme also provides the following benefits:

- Exclusive 24-Hour Toll-Free Assistance Line
- 24-Hour Emergency Towing
- 24-Hour Roadside Assistance
- 24-Hour Emergency Lockout Service (up to US \$100 per call out)
- Sign and Drive Service
- 24-Hour Emergency Trip Interruption Benefits
- 24-Hour Aston Martin Dealer Locator Service
- Repaired Vehicle Reunite Service
- Assistance Experience Survey Card.

The Aston Martin Roadside Assistance scheme benefits provide for towing to the nearest approved dealer. Should the vehicle breakdown occur 150 or more miles (241 or more km) from the nearest approved dealer and 150 or more miles (241 or more km) from the primary residence of the owner or operator, the owner or operator is entitled to trip interruption benefits. Trip interruption benefits include lodging and meals for up to 2 nights, and alternative transportation. Trip interruption benefits are limited to a maximum of US \$500 per interruption.

The term of the Aston Martin Roadside Assistance scheme runs concurrent with the Aston Martin New Vehicle Limited Warranty. The plan does not cover the following:

- Rental fleet vehicles
- Breakdowns caused by accident, vandalism, racing or abuse
- Additional towing costs for towing to other than the nearest approved dealer to the breakdown site.

Expenses for such items as entertainment, recreation, and non-essential goods and services are excluded from trip interruption benefits.

How Does the Plan Work

The national toll-free assistance telephone number is shown on your Roadside Assistance Membership Card and on the label on the drivers side door pillar.

If your Aston Martin vehicle suffers a breakdown whilst driving, call the toll-free number: 1- 888 - 59ASTON (1- 888-592-7866). It is available 24 hours a day.

 *It may be helpful to have the relevant telephone numbers entered into your mobile phone 'phone book'.*

Have your Aston Martin Roadside Assistance Membership Card ready.

Provide the Roadside Assistance Service Representative with:

- Your name
- The Vehicle Identification Number (VIN), which is printed on your Roadside Assistance Membership Card. The VIN is also printed on a decal on the drivers side dashboard. This decal may be viewed from outside the car by looking in through the front windshield.
- The vehicle location.
- Where you are calling from, including a telephone number on which you may be contacted.

The Roadside Assistance Service Representative will work with you to find the best solution to your concern. Please stay with the vehicle until assistance arrives.

Further Information

See the separate brochure provided for full details of the Aston Martin Roadside Assistance scheme. The terms of the scheme may be changed without notice.



Certification and Compliance

Component Certification D.2

Component Certification

Vehicle Key

FCC ID: OHT3731687

IC: 5461A-3731687

This device complies with Part 15 of the FCC Rules and with Innovation, Science and Economic Development Canada license-exempt RSS(s). Operation is subject to the following two conditions:

1. This device may not cause harmful interference, and
2. This device must accept any interference received, including interference that may cause undesired operation.

 *Changes or modifications not expressly approved by the party responsible for compliance could void the user's authority to operate the equipment.*

Connected Car Module

FCC - Radio Frequency Devices (USA)

⚠ FCC Warning: Changes not expressly approved by the party responsible for compliance could void the user's authority to operate the equipment.

FCC ID: 2AGKK103360002

This device complies with part 15 of the FCC Rules. Operation is subject to the following two conditions:

- (1) This device may not cause harmful interference, and
- (2) this device must accept any interference received, including interference that may cause undesired operation.

Notice: This equipment has been tested and found to comply with the limits for a Class B digital device, pursuant to part 15 of the FCC Rules. These limits are designed to provide reasonable protection against harmful interference in a residential installation. This equipment generates, uses, and can radiate radio frequency energy and, if not installed and used in accordance with the instructions, may cause harmful interference to radio communications.

However, there is no guarantee that interference will not occur in a particular installation. If this equipment does cause harmful interference to radio or television reception, which can be determined by turning the equipment off and on, the user is encouraged to try to correct the interference by one or more of the following measures:

- Reorient or relocate the receiving antenna.
- Increase the separation between the equipment and receiver.
- Connect the equipment into an outlet on a circuit different from that to which the receiver is connected.
- Consult the dealer or an experienced radio/TV technician for help.

IC - Radio Frequency Devices (Canada)

IC: 20839-103360002

This device contains licence-exempt transmitter(s)/ receiver(s) that comply with Innovation, Science and Economic Development Canada's licence-exempt RSS(s). Operation is subject to the following two conditions:

- (1) This device may not cause interference.
- (2) This device must accept any interference, including interference that may cause undesired operation of the device.

Radar Modules

Front Radar

FCC - Radio Frequency Devices (USA)

⚠️ FCC Warning: Changes not expressly approved by Robert BOSCH GmbH may void the FCC authorization to operate the equipment.

FCC ID: NF3-CR5CPCCF

This device complies with part 15 of the FCC Rules. Operation is subject to the following two conditions: (1) This device may not cause harmful interference, and (2) this device must accept any interference received, including interference that may cause undesired operation.

This equipment has been tested and found to comply with the limits for a Class A digital device, pursuant to Part 15 of the FCC Rules. These limits are designed to provide reasonable protection against harmful interference when the equipment is operated in a commercial environment. This equipment generates, uses, and can radiate radio frequency energy and, if not installed and used in accordance with the instruction manual, may cause harmful interference to radio communications. Operation of this equipment in a residential area is likely to cause harmful interference in which case the user will be required to correct the interference at his own expense.

Radiofrequency radiation exposure Information: This equipment complies with FCC radiation exposure limits set forth for an uncontrolled environment. This equipment should be installed and operated with minimum distance of 20 cm between the radiator and your body. This transmitter must not be co-located or operating in conjunction with any other antenna or transmitter.

IC - Radio Frequency Devices (Canada)

IC: 3887A-F5CP12

This device contains licence-exempt transmitter(s)/ receiver(s) that comply with Innovation, Science and Economic Development Canada's licence-exempt RSS(s). Operation is subject to the following two conditions:

- (1) This device may not cause interference.
- (2) This device must accept any interference, including interference that may cause undesired operation of the device.

Radiofrequency radiation exposure Information: This equipment complies with FCC and IC radiation exposure limits set forth for an uncontrolled environment. This equipment should be installed and operated with minimum distance of 20 cm between the radiator and your body. This transmitter must not be co-located or operating in conjunction with any other antenna or transmitter.

Blind Spot Assist

FCC - Radio Frequency Devices (USA)

⚠ FCC Warning: Changes not expressly approved by Robert BOSCH GmbH may void the FCC authorization to operate the equipment.

FCC ID: NF3-F5CP12

This device complies with part 15 of the FCC Rules. Operation is subject to the following two conditions: (1) This device may not cause harmful interference, and (2) this device must accept any interference received, including interference that may cause undesired operation.

This equipment has been tested and found to comply with the limits for a Class A digital device, pursuant to Part 15 of the FCC Rules. These limits are designed to provide reasonable protection against harmful interference when the equipment is operated in a commercial environment. This equipment generates, uses, and can radiate radio frequency energy and, if not installed and used in accordance with the instruction manual, may cause harmful interference to radio communications. Operation of this equipment in a residential area is likely to cause harmful interference in which case the user will be required to correct the interference at his own expense.

Radiofrequency radiation exposure Information: This equipment complies with FCC radiation exposure limits set forth for an uncontrolled environment. This equipment should be installed and operated with minimum distance of 20 cm between the radiator and your body. This transmitter must not be co-located or operating in conjunction with any other antenna or transmitter.

IC - Radio Frequency Devices (Canada)

IC: 3887A-CR5CPCCF

This device contains licence-exempt transmitter(s)/ receiver(s) that comply with Innovation, Science and Economic Development Canada's licence-exempt RSS(s). Operation is subject to the following two conditions:(1) This device may not cause interference. (2) This device must accept any interference, including interference that may cause undesired operation of the device.

Radiofrequency radiation exposure Information: This equipment complies with FCC and IC radiation exposure limits set forth for an uncontrolled environment. This equipment should be installed and operated with minimum distance of 20 cm between the radiator and your body. This transmitter must not be co-located or operating in conjunction with any other antenna or transmitter.

Homelink

USA

This device complies with Part 15 of the FCC Rules. Operation is subject to the following two conditions:

1. this device may not cause harmful interference, and
2. this device must accept any interference received, including interference that may cause undesired operation

 *Changes or modifications not expressly approved by the party responsible for compliance could void the user's authority to operate the equipment.*

Canada

This device contains licence-exempt transmitter(s)/ receiver(s) that comply with Innovation, Science and Economic Development Canada's licence-exempt RSS(s). Operation is subject to the following two conditions:

1. This device may not cause interference.
2. This device must accept any interference, including interference that may cause undesired operation.

Tire Pressure Monitoring System

Transmitter

FCC ID: **YGOTSSRE4A**

IC: **4008C-TSSRE4A**

USA

This device complies with Part 15 of the FCC Rules. Operation is subject to the following two conditions:

1. this device may not cause harmful interference, and
2. this device must accept any interference received, including interference that may cause undesired operation

 *Changes or modifications not expressly approved by the party responsible for compliance could void the user's authority to operate the equipment.*

Canada

This device contains licence-exempt transmitter(s)/ receiver(s) that comply with Innovation, Science and Economic Development Canada's licence-exempt RSS(s). Operation is subject to the following two conditions:

1. This device may not cause interference.
2. This device must accept any interference, including interference that may cause undesired operation.



Alphabetical Index

A

Accessory Sockets	3.34
Adaptive Cruise Control	5.16
Adaptive Damping	5.28
Airbags	3.17
Passenger Airbag Deactivation	3.22
Warning Labels	3.21
Anti-Theft Systems	2.13
Alarm	2.14
Engine Immobilizer	2.14
Motion Sensor	2.14
Tow Away Protection	2.14
Apple CarPlay	9.16
Aston Martin Dealers	A.2
Aston Martin Tracking	2.15
Audio	9.2
Aston Martin Audio	9.3
Bowers and Wilkins	9.2
Auto Main Beam	4.14
Automatic Emergency Braking	5.32
Automatic Locking	2.8

B

Blind Spot Assist	5.24
Hood Release	13.6
Brake Rotor Check	A.30
Brakes	5.29
ABS	5.31
Brake Warnings	5.30

Carbon Ceramic Brakes	5.30
Footbrake	5.29
Park Brake	5.35

C

Cabin Storage	3.32
Glove Box	3.32
Calls	7.4
Active Call	7.5
Conference Calls	7.7
Incoming Calls	7.4
Multiple Calls	7.6
Two Active Calls	7.6
Centre Console	1.5, 4.7
Centre Storage Box	3.33
Child Safety	3.20
Child Seat Installation	3.26
Occupant Classification System	3.22
Rear Child Seat Installation	3.27
Seat Belt Installation	3.26
Tether Anchors	3.28
Climate Control	
Automatic Climate Control	6.5
Manual Climate Control	6.6
Climate Controls	6.2
Infotainment	6.4
Switches	6.2
Connected Car	
Convenience Features	8.3
Vehicle Management Features	8.5

F.2 Alphabetical Index

Cruise Control	5.14
D	
Defrosting and Demisting	
Automatic	6.6
Drive Modes	5.10
GT	5.11
Individual	5.13
Sport	5.12
Sport+	5.12
Wet	5.11
Driver Attention Assist	5.23
Driving Position	
Quick Start	1.3
Driving Systems	
Lane Keep Assist	5.18
Traffic Sign Assist	5.22
Driving Techniques	5.2
E	
Easy Entry/Exit	2.9
Emergency Key	2.11
Emergency Start	2.13
Emission Warranty	13.3
Engine Oil Level	13.8
Check	13.9
Engine Start	5.4
Emergency Start	2.13
ESP (Electronic Stability Program)	5.37
Event Data Recorder	E.4

F

Fluid Capacities	13.13
Fluid Specifications	13.12
Fluids and Capacities	13.8
Fuel	13.58
Fuses	13.29

H

Homelink Wireless Control	2.20
---------------------------------	------

I

Information and Warnings	4.4
Instrument Cluster	
Driver Assistance	4.10
Media	4.12
Menu	4.9
Navigation	4.12
Trip Assist	4.11
View	4.11
Instrument Display	4.2

J

Jump Start	13.51
------------------	-------

K

Key Battery Replacement	2.4
-------------------------------	-----

L

Lamps	13.38
Lights	4.13
Auto Main Beam	4.14
Exterior Lamps	1.9, 4.13
Hazard Lamps	4.15

Indicators	1.8	Phone Charger	7.8
Interior Lamps	4.16	Q	
Reading Lamps	4.16	Quick Start	
Stalk Controls	1.8, 4.15	Infotainment	1.9
L		R	
Locking		Radio	
Automatic Locking	2.8	SiriusXM	9.6
Inside	2.8	SiriusXM Subscription	9.10
Outside	2.7	Replacement of Airbag Units Record	A.29
M		Replacement of Seat Belt Pre-tensioners Record	A.30
Media		S	
Portable Media	9.15	Satellite Radio	9.11
Sound Settings	9.18	Seat Belts	3.12
Memory Functions	3.9	Front Seat Belt Reminder	3.14
Mirrors	3.7	Rear Seat Belt Reminder	3.14
Exterior	3.7	Seats	3.2
Interior	3.7	Controls	3.3
N		Service Record	A.7
Navigation		Servicing	A.5
Map	10.3	Servicing Precautions	13.3
O		Settings	
Occupant Restraint System	3.11	System	12.6
Airbags	3.17	SiriusXM	9.6
Seat Belts	3.12	Subscription	9.10
Owner Maintenance Checks	13.5	Specifications	
P		Body	13.14
Park Assist Systems	5.45	Brakes	13.15
360° Camera System	5.47	Engine	13.45
Park Brake	5.35	Steering	13.15
Performance	13.47		

F.4 Alphabetical Index

Suspension	13.15
Transmission	13.46
Speed Control Systems	5.14
Speed Limiter	5.14
Steering Column	3.8
Steering Wheel Controls	1.6, 4.8
Stop/Start	5.43

T

Tether Anchors	3.28
Tool Kit	13.6
Track Days	5.2
Transmission Controls	5.5
Automatic	5.6
Manual Mode	5.9
Semi-Automatic Mode	5.7
Tire Pressure Monitoring System (TPMS)	5.41
Tires	13.17
Summer Tires	13.19
Tire Pressures	13.17
Tire Repair Kit	13.56
Winter Tires	13.20

U

Unlocking and Opening	2.6
Deck Lid	2.9
Deck Lid Emergency Access	2.12
Easy Entry/Exit	2.9
Emergency Key	2.11
Inside	2.8
Outside	2.6

V

Variable Load Space	3.33
Variable Speed Limiter	5.15
Vehicle Controls	1.5
Vehicle Key	2.2
Battery	2.3
Emergency Key	2.11
One Step Unlocking	2.3
Quick Start	1.2
Vehicle Provenance	A.3
Vehicle Recovery	13.50
Vehicle Settings	12.2
Assistance	12.3
Drive Modes	12.2
Lights	12.4
Parking	12.5
Telemetry	12.3
Vehicles	12.5

W

Warnings	
Brakes	5.30
Warning Symbols	4.4
Washers and Wipers	13.13
Windows	3.5
Windscreen Wipers	1.8, 4.12
Wireless Phone Charger	7.8